

---

INSTRUCTION BOOK FOR  
Fast-Fold® NXT

---



## Disclaimer

---

Milestone and its affiliated corporations and subsidiaries (collectively "Milestone"), intend to make this manual accurate and complete. However, Milestone makes no claim that the information contained herein covers all details, conditions or variations, nor does it provide for every possible contingency in connection with the installation or use of this subject to change without notice or obligation of any kind. Milestone makes no representation of warranty, expressed or implied, regarding the information contained herein. Milestone assumes no responsibility for accuracy, completeness or sufficiency of the information contained in this document.

Da-Lite® is a registered trademark of Milestone AV Technologies. All rights reserved.

## Fast-Fold NXT

---

The Fast-Fold NXT screen system will have a 1 $\frac{3}{4}$ " wide frame or a 3 $\frac{1}{2}$ " wide frame depending on the size ordered. Screen assembly is the same regardless of the frame size.

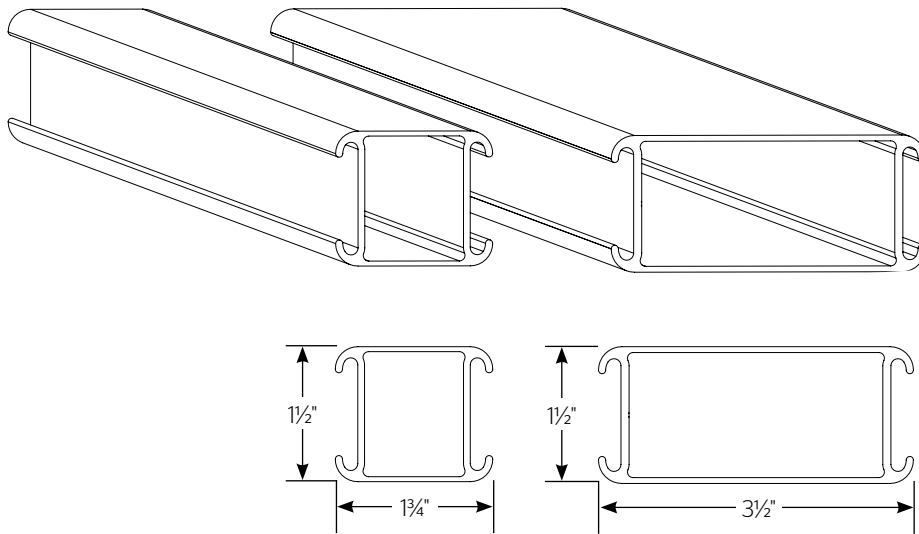

# Fast-Fold NXT Assembly Instructions

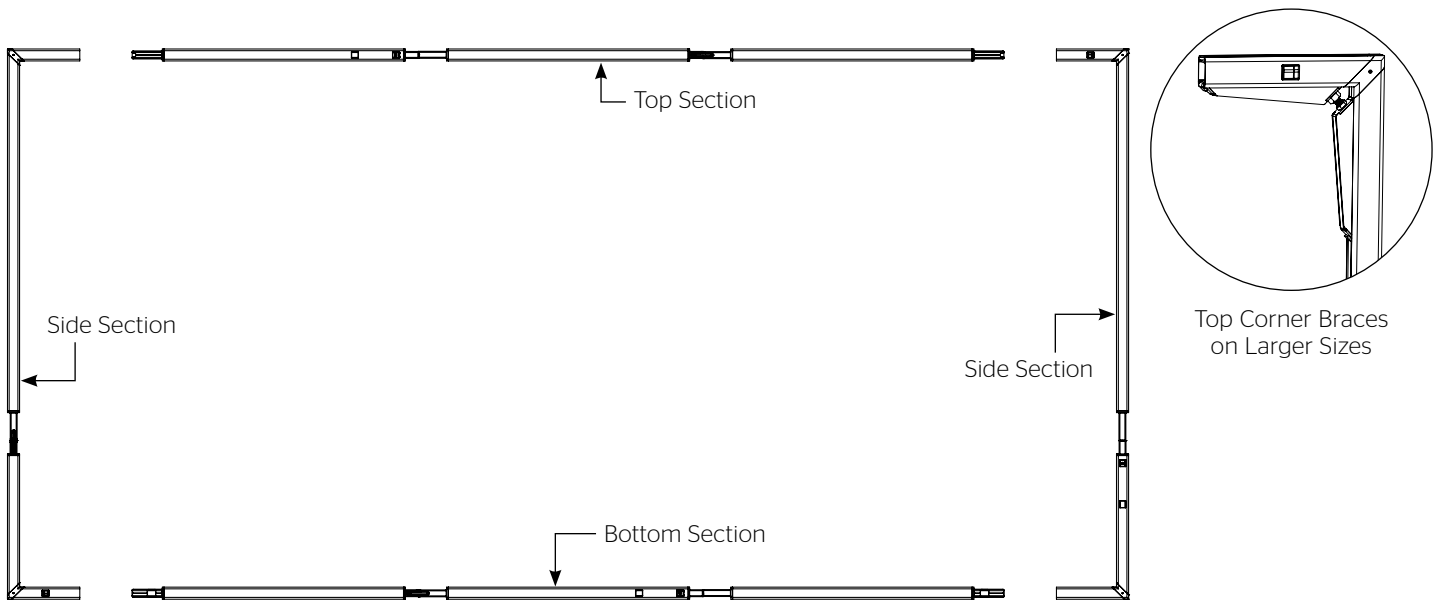

Figure 1

1. Unfold the four sections of the Fast-Fold NXT frame, lock all internal sliding hinges and lay face up on the floor. See Figure 2.

2. Assemble the frame by sliding both the top and bottom sections into a side section. Slide the sections together until the corner latches engage. Slide the remaining side section onto the top and bottom sections to complete the assembly. See Figure 3.

**NOTE:** The longer frame sections for the top & bottom are interchangeable and the shorter side sections are interchangeable. For larger sizes that include corner braces in the top corners, the side sections are interchangeable, but not reversible. The braces must remain on top.

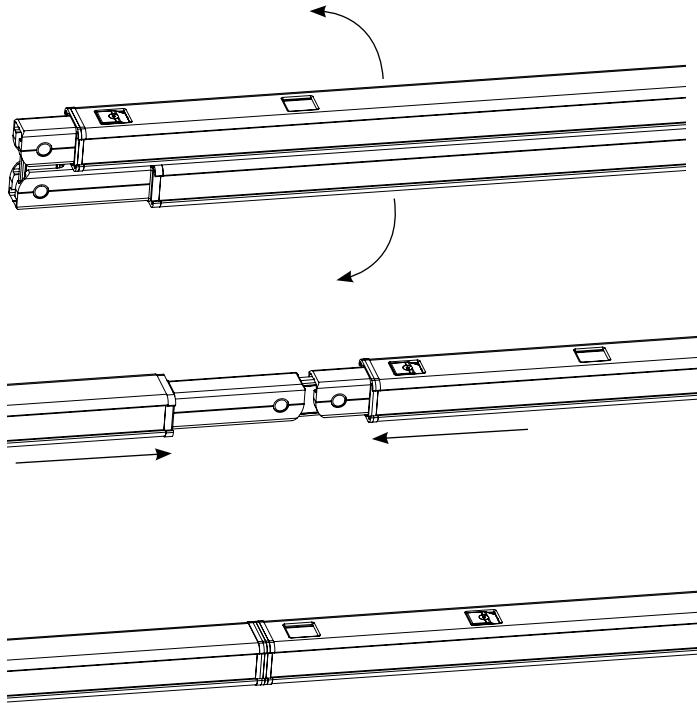

Figure 2

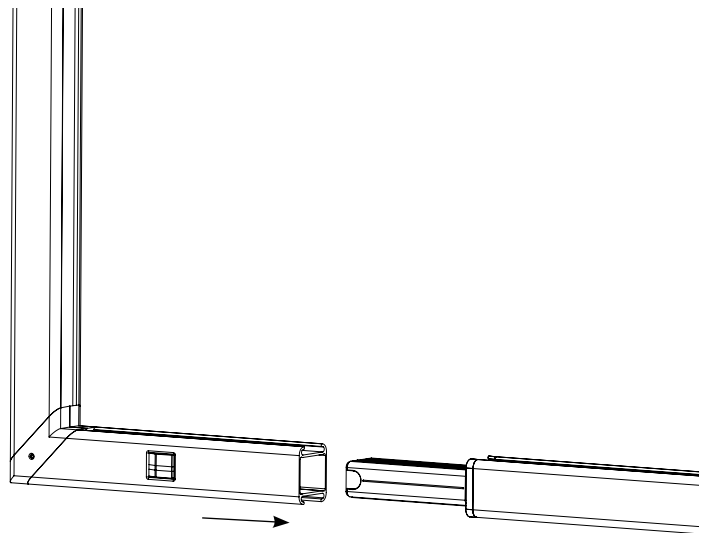

Figure 3

# Fast-Fold NXT Assembly Instructions (continued)

3. Assemble the legs by sliding the three sections together and tightening the Leg Knobs. See Figure 4.

**NOTE:** The top extension sections may not be needed depending on the desired screen height.

4. Attach legs to side frame members at the location indicated on the frame. See Figure 5.

**NOTE:** Leg Knobs should face away from the frame.

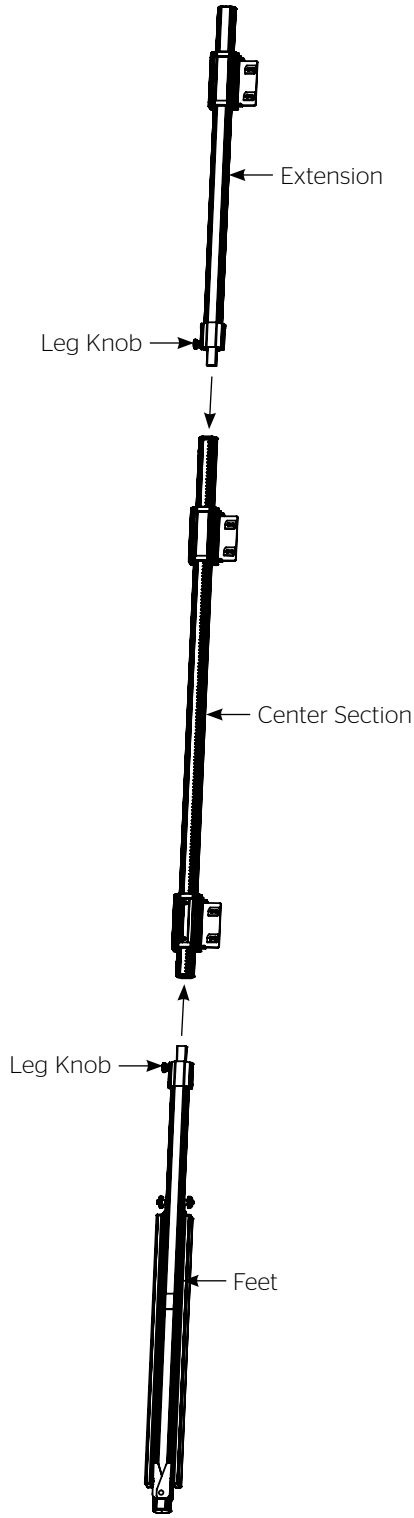

Figure 4

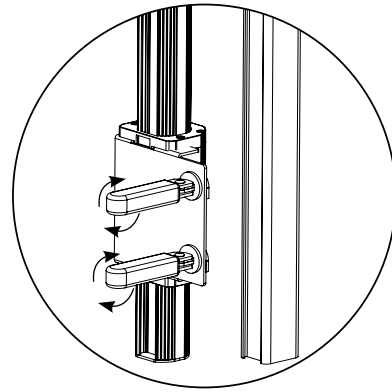

Figure 5a

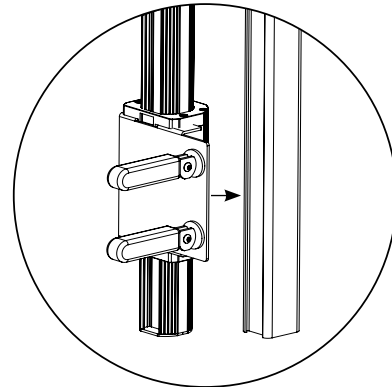

Figure 5b

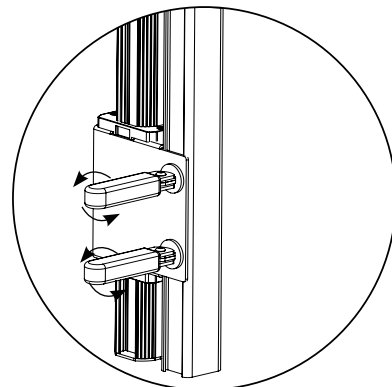

Figure 5c

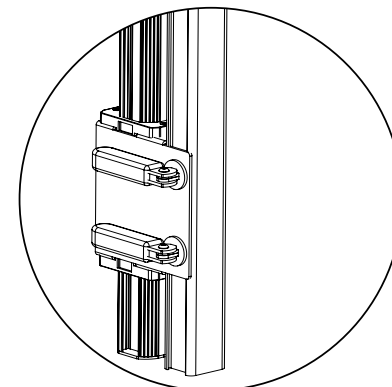

Figure 5d

## Fast-Fold NXT Assembly Instructions (continued)

5. Match the bottom of the screen surface with bottom of frame by locating the label in the bottom right hand corner of the surface.
  6. Attach clips on both sides of corner at all four corners. To maintain even surface tension, attach the corners in a diagonal pattern. See Figure 6.
- NOTE:** Attach at least four clips in each corner, two clips per side.
7. Starting at the bottom section, attach the center clip. Continue attaching the remaining clips.
  8. Attach the top and sides in the same manner.

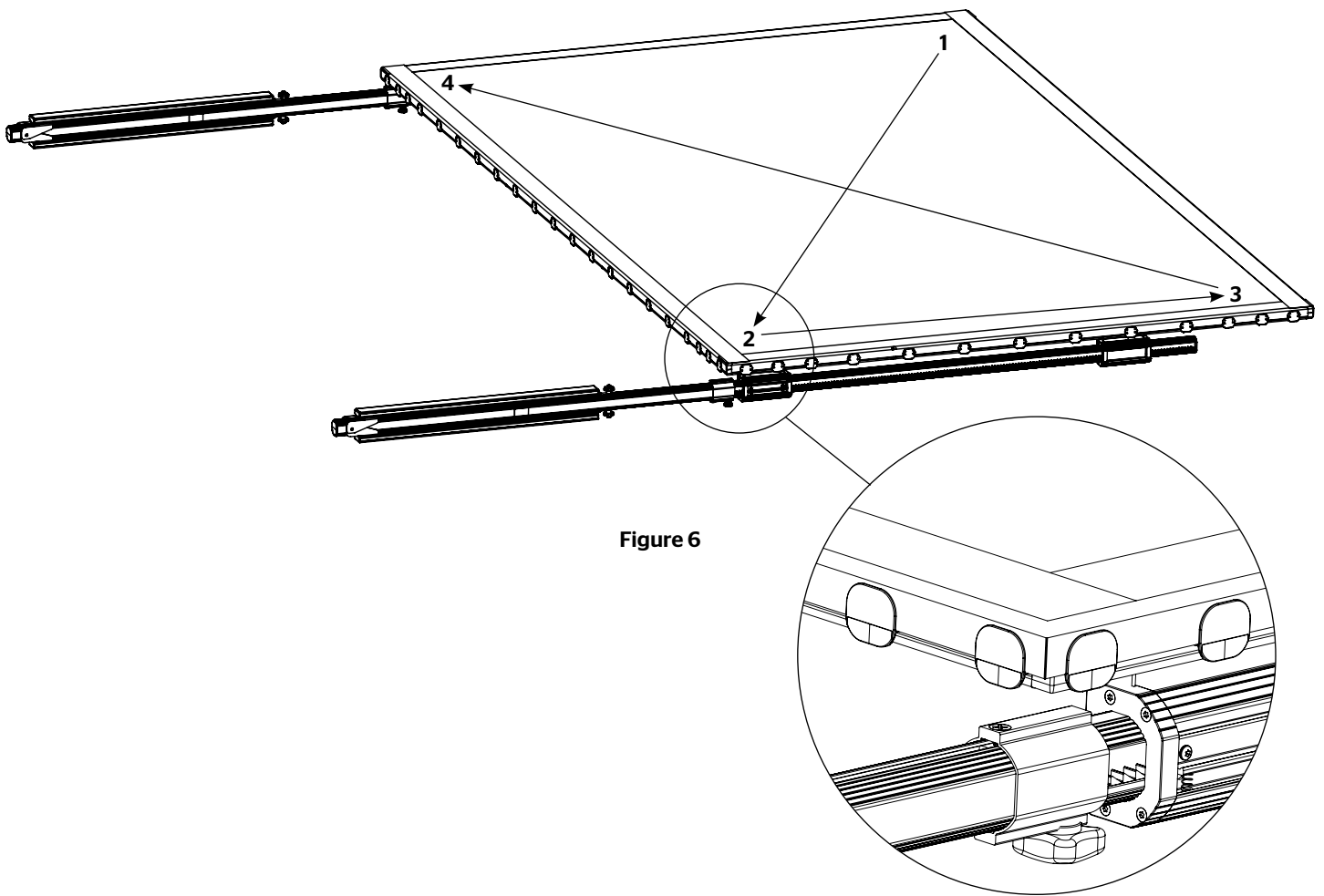

Figure 6

## Fast-Fold NXT Assembly Instructions (continued)

9. Height Adjustment. Fast-Fold NXT screen height is adjustable in 3/8" (10 mm) increments either up or down. Normal screen height is 44" (112 cm) from bottom of frame to floor and is the standard height for use with presentation drapery accessories. To adjust screen height, use the release handle on the leg coupler. Lift slightly while depressing the release handle. See Figure 7.

**NOTE:** Do not extend frame so that more than half of the frame height is above the top of the coupler.

10. Raise front foot of each leg and lock foot slide at 90 degree mark by turning knob clockwise. See Figure 8.

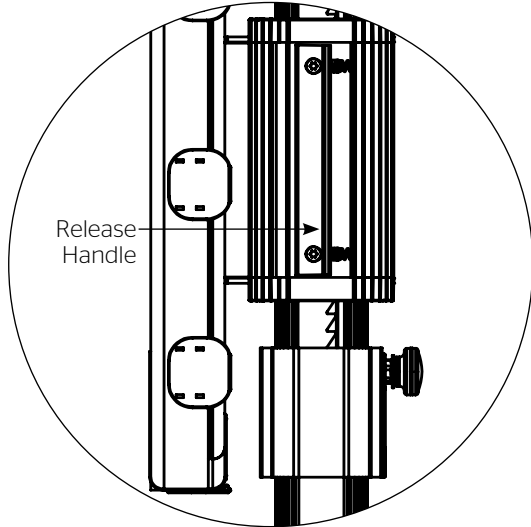

Figure 7

11. With one person at each leg, raise to standing position.
- NOTE:** With large screens, more than two people may be required.
12. Lower back foot and lock foot slide at 90 degree mark by turning knob clockwise. See Figure 8.
13. To pack, reverse procedure. Use caution to prevent surface damage.

**NOTE:** When disassembling the frame, be sure to fully extend the internal hinges before folding to prevent damage.

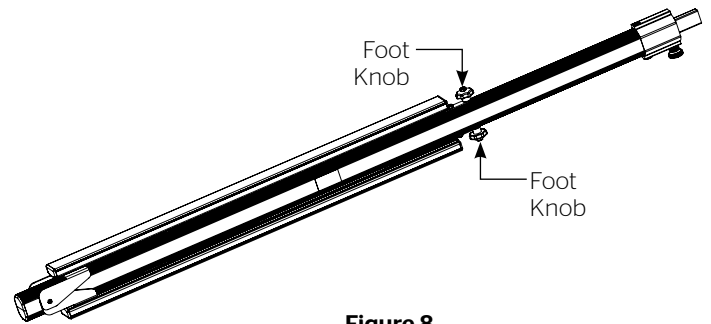

Figure 8

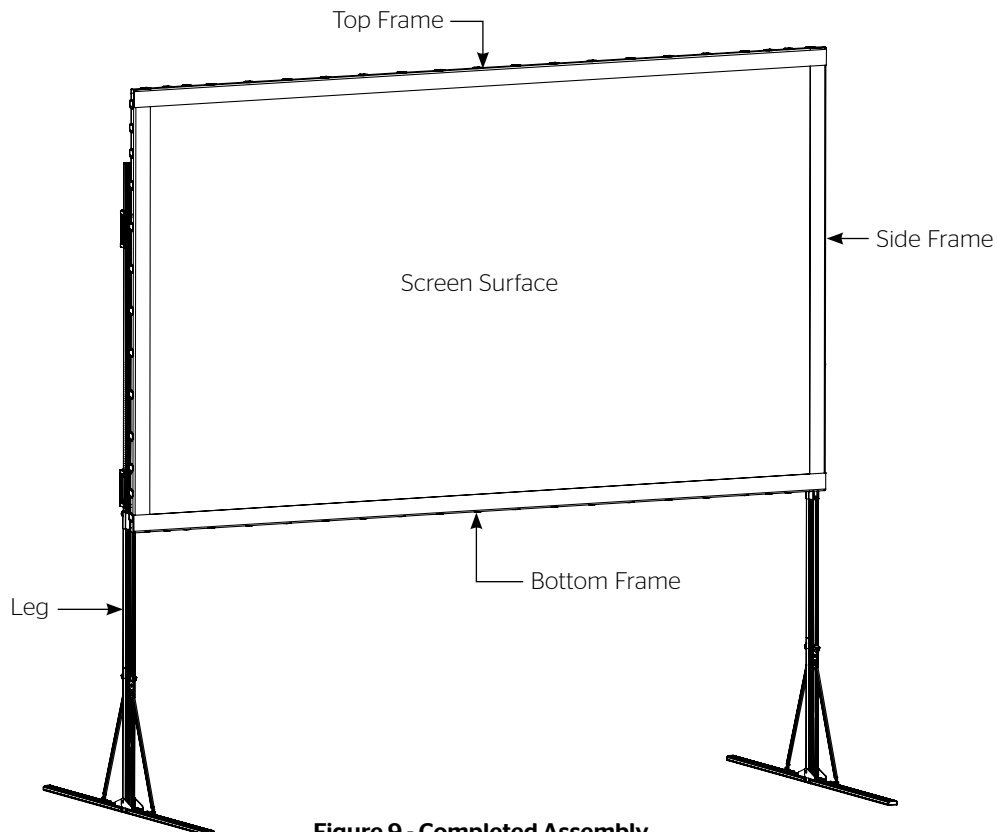

Figure 9 - Completed Assembly

# Surface Folding Instructions

Please follow the steps as outlined below when folding the screen material for packing:

1. Make sure the surface does not come in contact with a painted, varnished, plastic, or dyed surface or object. Prolonged contact with any one of these materials could cause a chemical reaction and compromise the screen's physical or optical quality. This can be accomplished by laying a white clean cotton fabric or paper (slightly larger than the screen size) on a flat surface prior to folding the screen.
2. With the surface face up, fold the fabric in half from top to bottom. Stop just short of the clips so there are no clips stacked on top of each other (A 7.5' x 10' screen is now 3.75' x 10'). Make sure the clips are staggered on the side.

**NOTE:** Make sure that the screen never comes in contact with the black binding or clips. Please note that for this to happen, one must make sure all folds subsequent to the first fold stop short of black binding material as illustrated below.

3. Place clean tissue paper or white 100% cotton material between the folds.
4. If the folded area is more than 3 feet wide (which is the case in the above example), then continue to fold until the folded area is equal to or smaller than 3 feet wide.

**NOTE:** Please remember that all folds subsequent to the first fold must stop short of the black binding material to keep the viewing area away from it and the clips as illustrated above.

5. Once the top to bottom folding is completed, fold from left to right and continue folding until the folded area is small enough to fit into the vinyl pouch.

**NOTE:** The final fold must stop short of the black binding material to keep the viewing area away from it and the clips as illustrated.

6. Place the pouch in the poly case on top of the hardware with the rigid side of the pouch down.

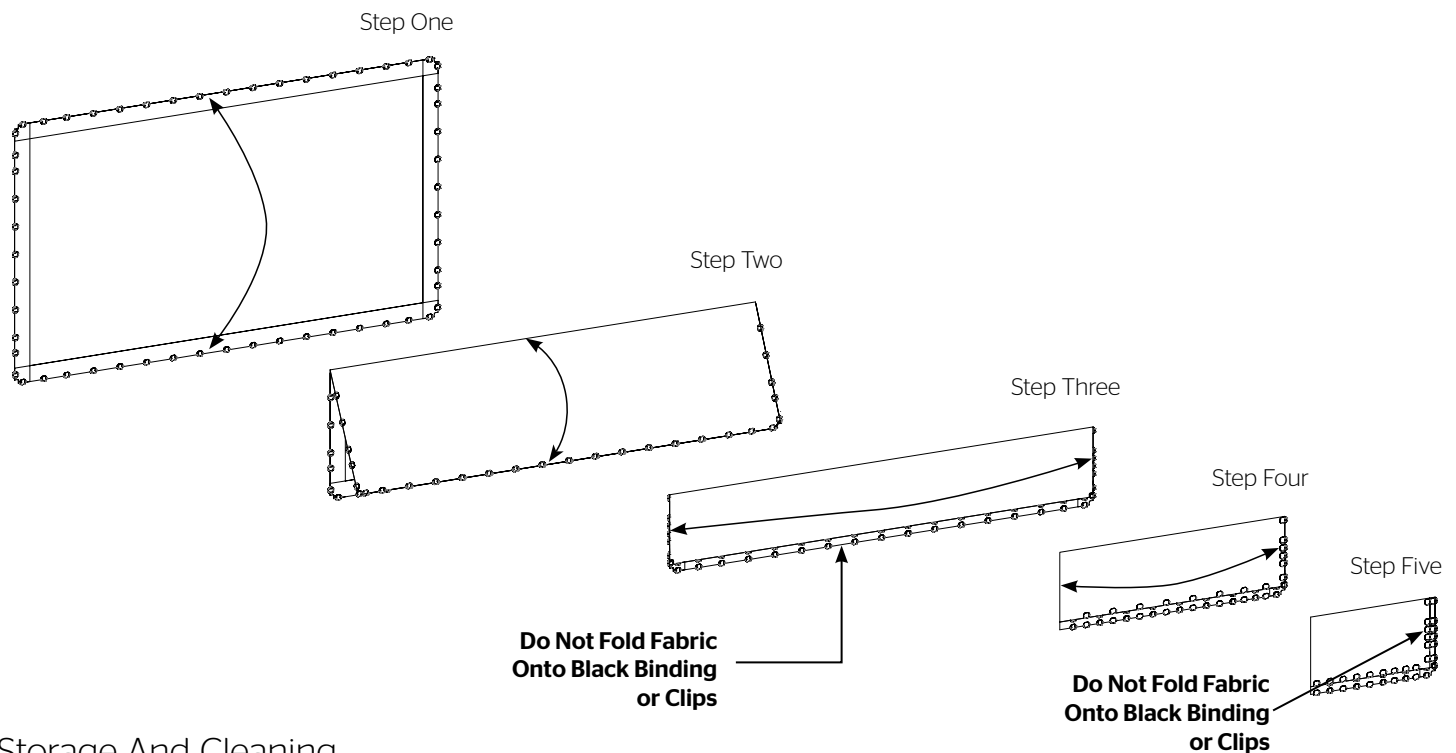

## Storage And Cleaning

### Storage

1. The screen surface must be stored in its pouch when not in use to prevent damage and discoloration.
2. While in storage, avoid extreme temperature conditions. If surface becomes sticky, see cleaning instructions below.
3. If stored at temperatures far below room temperature, allow the screen to warm up to room temperature before unfolding. This will ensure the film is being handled in its most flexible state and will prevent surface cracks.

### Cleaning

Surfaces can be cleaned as follows:

Using a white clean cloth (100% cotton preferred) that is dampened with clear water, gently wipe the area in one direction. Do not use a circular motion. Using a dry 100% cotton cloth, wipe dry after each cleaning session. To clean a stubborn stain or a sticky surface, use denatured alcohol (methanol or methyl alcohol) following the same procedure as for water. For extremely stubborn stains, use V M & P, Naphtha or Super Naphtha and follow the same procedure as for water.

## LIMITED WARRANTY - FAST-FOLD NXT PRODUCTS

Milestone AV Technologies LLC warrants its Da-Lite branded products to the original purchaser only, to be free from defects in materials and workmanship in accordance with the following warranty term:

A period of five (5) years for the Fast-Fold NXT frame and related components; and

A period of two (2) years for the Fast-Fold NXT screen surface and related components.

The foregoing warranty will commence upon the date of purchase by the original purchaser and is expressly contingent upon the products being properly operated according to Da-Lite's instructions and not damaged due to improper handling or treatment after shipment from the factory.

This warranty does not apply to equipment showing evidence of misuse, abuse or accidental damage, or which has been tampered with or repaired by a person other than authorized Da-Lite personnel.

Da-Lite's sole obligation under this warranty shall be to repair or to replace (at Da-Lite's option) the defective part of the merchandise. Returns for service should be made to your Da-Lite dealer. If it is necessary for the dealer to return the screen or part to Da-Lite, transportation expenses to and from Da-Lite are payable by the purchaser and Da-Lite is not responsible for damage in shipment. To protect yourself against damage or loss in transit, insure the product and prepay all transportation expenses.

**TO THE MAXIMUM EXTENT PERMITTED BY APPLICABLE LAW, THIS WARRANTY IS IN LIEU OF ALL OTHER WARRANTIES, EXPRESS OR IMPLIED, INCLUDING WARRANTIES AS TO FITNESS FOR USE AND MERCHANTABILITY.** Any implied warranties of fitness for use, or merchantability, that may be mandated by statute or rule of law are limited to the one (1) year warranty period. This warranty gives you specific legal rights, and you may also have other rights, which vary from state-to-state. **TO THE MAXIMUM EXTENT PERMITTED BY APPLICABLE LAW, NO LIABILITY IS ASSUMED FOR EXPENSES OR DAMAGES RESULTING FROM INTERRUPTION IN OPERATION OF EQUIPMENT, OR FOR INCIDENTAL, DIRECT, OR CONSEQUENTIAL DAMAGES OF ANY NATURE.**

In the event that there is a defect in materials or workmanship of a Da-Lite product, you may contact our Customer Care Specialists at 3100 North Detroit Street, Warsaw, IN 46582, (574) 267-8101, (800) 622-3737.

**IMPORTANT: THIS WARRANTY SHALL NOT BE VALID AND DA-LITE BRANDED PRODUCTS SHALL NOT BE BOUND BY THIS WARRANTY IF THE PRODUCT IS NOT OPERATED IN ACCORDANCE WITH THE DA-LITE WRITTEN INSTRUCTIONS.**

Keep your sales receipt to prove the date of purchase and your original ownership.



**A BRAND OF MILESTONE AV TECHNOLOGIES** | [www.milestone.com](http://www.milestone.com)

**P** 800.622.3737 / 574.267.8101 **F** 877.325.4832 / 574.267.7804

**E** [info@da-lite.com](mailto:info@da-lite.com)

In British Columbia, Milestone AV Technologies ULC carries on business as MAVT Milestone AV Technologies ULC.

©2017 Milestone AV Technologies. DL-0710 (Rev. 1) 04-17.

Da-Lite is a registered trademark of Milestone AV Technologies. All other brand names or marks are used for identification purposes and are trademarks of their respective owners. All patents are protected under existing designations. Other patents pending.