S P E C F I L E



Product Number : **PT-RW430K/RW430W**

Product Name : DLP™ Projector

Specifications

Main unit

Power supply		100–240 V AC, 5.2–2.0 A, 50/60 Hz
Power consumption		460 W (470 VA) (250 W* ¹ with LIGHT POWER set to NORMAL, 200 W* ¹ with LIGHT POWER set to Ecosave1, 178 W* ¹ with LIGHT POWER set to Ecosave2. 0.5 W with STANDBY MODE set to ECO* ² , 8 W with STANDBY MODE set to NORMAL)
DLP™ chip	Panel size	16.5 mm (0.65 in) diagonal (16:10 aspect ratio)
	Display method	DLP™ chip × 1, DLP™ system
	Pixels	1,024,000 (1,280 × 800) × 1, total of 1,024,000 pixels
Lens		Manual zoom (2.0×), manual focus, F 2.0–3.4, f 21.5–43.0 mm
Throw ratio		1.53–3.09:1
Light source		LED/laser-combined (R, B: LED; G: laser diode)
Screen size		1.02–7.62 m (40–300 inches) diagonally, 16:10 aspect ratio
Brightness* ³		3,500 lumens
Center-to-corner uniformity* ³		90%
Contrast* ³		20,000:1 (full on/off)
Resolution		1,280 × 800 pixels (Input signals that exceed this resolution will be converted to 1,280 × 800 pixels.)
Scanning frequency	HDMI/DVI-I (digital) DVI-I (analog)/RGB YPbPr (YCbCr)	fH: 27–100 kHz, fV: 24–120 Hz, dot clock: 25–162 MHz fH: 15–100 kHz, fV: 24–120 Hz, dot clock: 162 MHz or lower 480i (525i): fH 15.75 kHz; fV 60 Hz, 576i (625i): fH 15.63 kHz; fV 50 Hz, 480p (525p): fH 31.50 kHz; fV 60 Hz, 576p (625p): fH 31.25 kHz; fV 50 Hz, 720 (750)/60p: fH 45.00 kHz; fV 60 Hz, 720 (750)/50p: fH 37.50 kHz; fV 50 Hz, 1035 (1125)/60i: fH 33.75 kHz; fV 60 Hz, 1080 (1125)/60i: fH 33.75 kHz; fV 60 Hz, 1080 (1125)/50i: fH 28.13 kHz; fV 50 Hz, 1080 (1125)/25p: fH 28.13 kHz; fV 25 Hz, 1080 (1125)/24p: fH 27.00 kHz; fV 24 Hz, 1080 (1125)/24sF: fH 27.00 kHz; fV 48 Hz, 1080 (1125)/30p: fH 33.75 kHz; fV 30 Hz, 1080 (1125)/60p: fH 67.50 kHz; fV 60 Hz, 1080 (1125)/50p: fH 56.25 kHz; fV 50 Hz
	Video	fH: 15.75 kHz, fV: 60 Hz [NTSC/NTSC4.43/PAL-M/PAL60] fH: 15.63 kHz, fV: 50 Hz [PAL/PAL-N/SECAM]
Optical axis shift		Vertical: +69%, -46% (manual), horizontal: +28%, -37% (manual)
Keystone correction range		Vertical: ±40°
Installation		Ceiling/floor, front/rear
Terminals	HDMI IN	HDMI 19-pin × 1, HDCP compatible, Deep Color compatible 480p (525p), 576p (625p), 720 (750)/60p, 720 (750)/50p, 1080 (1125)/60i, 1080 (1125)/50i, 1080 (1125)/25p, 1080 (1125)/24p, 1080 (1125)/24sF, 1080 (1125)/30p, 1080 (1125)/60p, 1080 (1125)/50p, VGA (640 × 480)–WUXGA* ⁴ (1,920 × 1,200), compatible with non-interlaced signals only, dot clock: 25–162 MHz, audio signal: linear PCM (sampling frequencies: 48 kHz, 44.1 kHz, 32 kHz)
	DVI-I IN	DVI-I 29-pin × 1
	Digital	DVI 1.0 compliant, HDCP compatible, for single link only 480p, 576p, 720/60p, 720/50p, 1080/60i, 1080/50i, 1080/24p, 1080/24sF, 1080/25p, 1080/30p, 1080/60p, 1080/50p, VGA (640 × 480)–WUXGA* ⁴ (1,920 × 1,200), compatible with non-interlaced signals only, dot clock: 25–162 MHz
	R, G, B	R: 0.7 Vp-p, 75 ohms, G: 0.7 Vp-p (G: 1.0 Vp-p for sync on G), 75 ohms, B: 0.7 Vp-p, 75 ohms HD/VD, SYNC: TTL, high impedance, positive/negative automatic NOTE: HD/SYNC, and VD terminals do not accept tri-level sync signals.
	Y, Pb, Pr (Y, Cb, Cr)	Y: 1.0 Vp-p (including sync signal), Pb/Pr (Cb/Cr): 0.7 Vp-p, 75 ohms

COMPUTER (RGB) IN R, G, B	D-sub HD 15-pin (female) × 1 R: 0.7 Vp-p, 75 ohms, G: 0.7 Vp-p (G: 1.0 Vp-p for sync on G), 75 ohms, B: 0.7 Vp-p, 75 ohms HD/VD, SYNC: TTL, high impedance, positive/negative automatic NOTE: HD/SYNC, and VD terminals do not accept tri-level sync signals.
Y, PB, PR (Y, CB, CR)	Y: 1.0 Vp-p (including sync signal), PB/PR (Cb/Cr): 0.7 Vp-p, 75 ohms
VIDEO IN	RCA pin × 1, 1.0 Vp-p, 75 ohms
AUDIO IN	M3 (L, R) × 1, 0.5 Vrms
AUDIO OUT	M3 (L, R) × 1 (monitor out: 0–1.8 Vrms, variable)
SERIAL IN	D-sub 9-pin (female) × 1 for external control (RS-232C compliant)
LAN / DIGITAL LINK	RJ-45 × 1 for network and DIGITAL LINK (video/audio/network/serial control) connection, 100Base-TX, compatible with PLink™, HDCP compatible, Deep Color compatible, 480p (525p), 576p (625p), 720 (750)/60p, 720 (750)/50p, 1080 (1125)/60i, 1080 (1125)/50i, 1080 (1125)/25p, 1080 (1125)/24p, 1080 (1125)/24sF, 1080 (1125)/30p, 1080 (1125)/60p, 1080 (1125)/50p, VGA (640 × 480)–WUXGA*4 (1,920 × 1,200), compatible with non-interlaced signals only, dot clock: 25–162 MHz
3D SYNC OUT	Mini DIN 3-pin × 1, for 3D transmitter connection
Power cord length	3.0 m (9 ft 10 in)
Cabinet materials	Molded plastic
Dimensions (W × H × D)	455 × 137*5 × 415 mm (17-29/32 × 5-13/32*5 × 16-11/32 inches) (lens included)
Weight*6	Approx. 11.0 kg (24.3 lbs)
Operation noise*3	35 dB (LIGHT SOURCE MODE: NORMAL), 29 dB (LIGHT SOURCE MODE: LOW)
Operating temperature	0–45 °C (32–113 °F)*7
Operating humidity	20%–80% (no condensation)
Wireless remote control unit	
Power supply	3 V DC (R6/LR6/AA type battery × 2)
Operation range*8	Approx. 15 m (49 ft 3 in) when operated from directly in front of the signal receptor
Dimensions (W × H × D)	48 × 163 × 24.5 mm (1-13/32 × 6-5/8 × 31/32 inches)
Weight	Approx. 117 g (4.1 oz) (including batteries)
Supplied accessories	
	Power cord with security lock (× 1) (Power cord × 2 for PT-RW430EA) Wireless remote control unit (× 1) Batteries for remote control (R6/LR6/AA type × 2) Software CD-ROM (Logo Transfer Software, Multi Projector Monitoring & Control Software) (× 1)
Optional accessories	
Digital Interface box	ET-YFB100G
Ceiling mount bracket	ET-PKR100H (for high ceilings) ET-PKR100S (for low ceilings)
Portrait mode mount bracket	ET-PKR100P

Weights and dimensions shown are approximate. Specifications and appearance are subject to change without notice.
 *1 In STANDARD/GRAPHIC picture mode. Measured based on the power consumption rate and a measurement method for the TV receiver.
 *2 When the STANDBY MODE is set to ECO, network functions such as power on over the LAN network will not operate. Also, only certain commands can be received for external control using the serial terminal.
 *3 Measurement, measuring conditions, and method of notation all comply with ISO 21118 international standards.
 *4 WUXGA resolution is supported only when the signals are compliant with VESA CVT-RB (Coordinated Video Timing-Reduced Blanking).
 *5 With legs at shortest position.
 *6 Average value. May differ depending on the actual unit.
 *7 0–40 °C (32–104 °F) between 1,400 m and 2,700 m (4,593 ft and 8,858 ft) above sea level. If the ambient temperature exceeds 35 °C (95 °F), the light output may be reduced to protect the projector.
 *8 Operation range differs depending on environments.

Dimensions

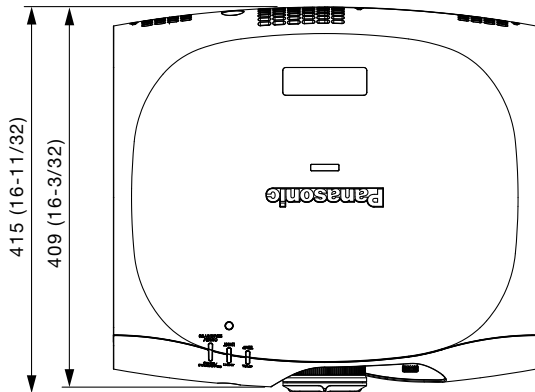

unit : mm (inch)

NOTE: This illustration is not drawn to scale.

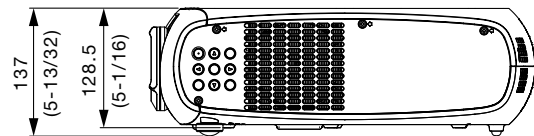
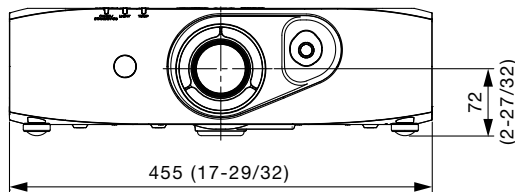

Terminals

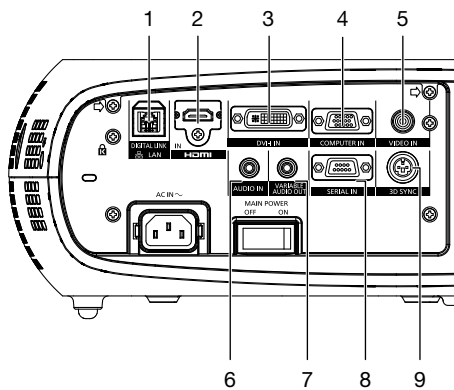

- 1 LAN / DIGITAL LINK connector
- 2 HDMI input
- 3 DVI-I input
- 4 Computer input
- 5 Video input
- 6 Audio input
- 7 Audio output
- 8 Serial input
- 9 3D SYNC output

Standard setting-up position

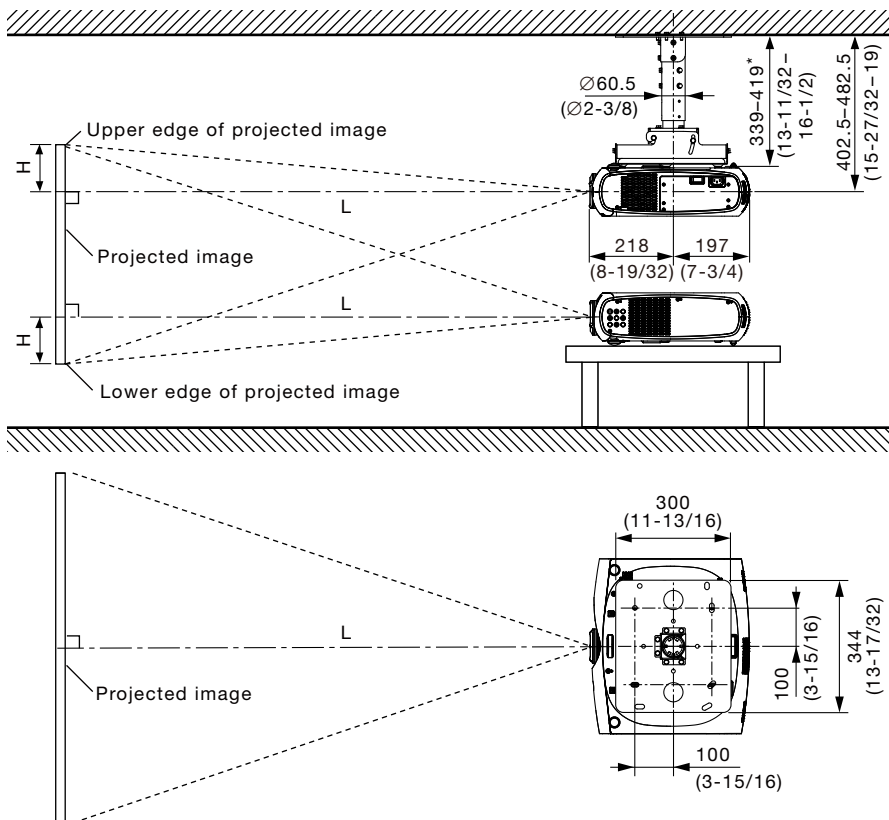

NOTE:

Illustrations show the projector installed using optional ceiling mount bracket ET-PKR100H.

This illustration is not drawn to scale.

* Adjustable in 40 mm (1-9/16 in) steps.

unit : mm (inch)

Caution:

- All construction work should be done by a qualified technician.
- When mounting to the ceiling, use the ceiling mount bracket. Also, to prevent the projector from dropping, be sure to attach the wire that is included with the ceiling mount bracket.

Projection distance for 16:10 aspect ratio screen

unit: meters (feet)

Projection size [diagonal] [m] [in]	Projection distance [L]		Height from the edge of screen to center of lens [H]	
	Min [wide]	Max [telephoto]		
1.02 / 40	1.3 (4.2)	2.6 (8.7)	-0.10 - 0.52	(-0.3 - 1.7)
1.27 / 50	1.6 (5.3)	3.3 (10.9)	-0.13 - 0.65	(-0.4 - 2.1)
1.52 / 60	2.0 (6.4)	4.0 (13.1)	-0.15 - 0.78	(-0.5 - 2.5)
1.78 / 70	2.3 (7.5)	4.6 (15.3)	-0.18 - 0.91	(-0.6 - 3.0)
2.03 / 80	2.6 (8.6)	5.3 (17.5)	-0.21 - 1.03	(-0.7 - 3.4)
2.29 / 90	3.0 (9.7)	6.0 (19.6)	-0.23 - 1.16	(-0.8 - 3.8)
2.54 / 100	3.3 (10.9)	6.7 (21.8)	-0.26 - 1.29	(-0.8 - 4.2)
3.05 / 120	4.0 (13.1)	8.0 (26.2)	-0.31 - 1.55	(-1.0 - 5.1)
3.81 / 150	5.0 (16.4)	10.0 (32.8)	-0.38 - 1.94	(-1.3 - 6.4)
5.08 / 200	6.7 (21.9)	13.4 (43.8)	-0.51 - 2.59	(-1.7 - 8.5)
6.35 / 250	8.3 (27.4)	16.7 (54.8)	-0.64 - 3.23	(-2.1 - 10.6)
7.62 / 300	10.0 (32.9)	20.1 (65.8)	-0.77 - 3.88	(-2.5 - 12.7)

NOTE:

- The value for L (distance to screen) varies slightly within ±5% depending on the zoom lens characteristics.
- The zoom lens characteristics may cause slight image distortion.
- When vertical keystone correction is used, the image is corrected in the direction that reduces its projected size.
- The brightness varies depending on the zoom setting.

Projection distance for 16:9 aspect ratio screen

unit: meters (feet)

Projection size [diagonal] [m] [in]	Projection distance [L]		Height from the edge of screen to center of lens [H]	
	Min [wide]	Max [telephoto]		
1.02 / 40	1.3 (4.4)	2.7 (8.9)	-0.05 – 0.48 (-0.2 – 1.6)	
1.27 / 50	1.7 (5.5)	3.4 (11.2)	-0.06 – 0.60 (-0.2 – 2.0)	
1.52 / 60	2.0 (6.6)	4.1 (13.4)	-0.08 – 0.71 (-0.2 – 2.3)	
1.78 / 70	2.4 (7.8)	4.8 (15.7)	-0.09 – 0.83 (-0.3 – 2.7)	
2.03 / 80	2.7 (8.9)	5.5 (17.9)	-0.10 – 0.95 (-0.3 – 3.1)	
2.29 / 90	3.1 (10.0)	6.2 (20.2)	-0.11 – 1.07 (-0.4 – 3.5)	
2.54 / 100	3.4 (11.2)	6.8 (22.4)	-0.13 – 1.19 (-0.4 – 3.9)	
3.05 / 120	4.1 (13.5)	8.2 (27.0)	-0.15 – 1.43 (-0.5 – 4.7)	
3.81 / 150	5.1 (16.9)	10.3 (33.7)	-0.19 – 1.79 (-0.6 – 5.9)	
5.08 / 200	6.9 (22.5)	13.7 (45.0)	-0.25 – 2.38 (-0.8 – 7.8)	
6.35 / 250	8.6 (28.2)	17.2 (56.3)	-0.31 – 2.98 (-1.0 – 9.8)	
7.62 / 300	10.3 (33.9)	20.6 (67.6)	-0.37 – 3.57 (-1.2 – 11.7)	

NOTE:

- The value for L (distance to screen) varies slightly within $\pm 5\%$ depending on the zoom lens characteristics.
- The zoom lens characteristics may cause slight image distortion.
- When vertical keystone correction is used, the image is corrected in the direction that reduces its projected size.
- The brightness varies depending on the zoom setting.

Calculation of the projection distance

For a screen size different from the above, use the equation below to calculate the projection distance.

Aspect ratio 16:10

minimum L (m) = (diagonal screen size in inches) \times 0.0336 – 0.0542maximum L (m) = (diagonal screen size in inches) \times 0.0670 – 0.0407

Aspect ratio 16:9

minimum L (m) = (diagonal screen size in inches) \times 0.0346 – 0.0542maximum L (m) = (diagonal screen size in inches) \times 0.0688 – 0.0407

NOTE:

Distances calculated with the above equations will include a slight error.

Shift range

Optical axis shift function allows to shift the position of a projected image as shown below.

• **Floor mount**

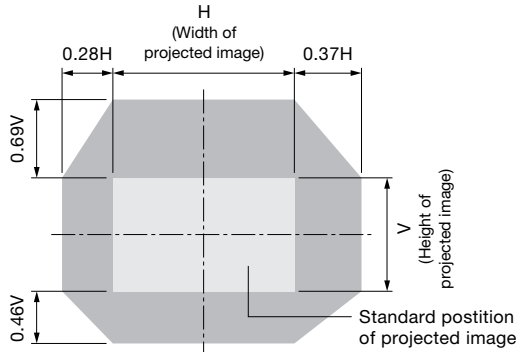

• **Ceiling mount**

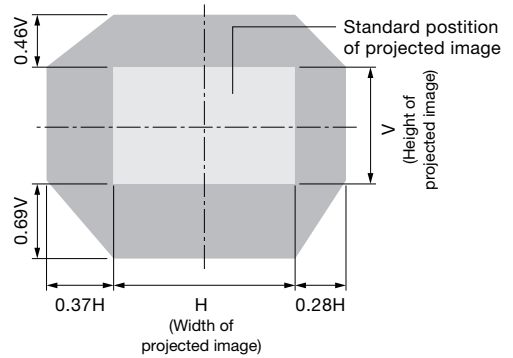

Installable angle

Install the projector at an angle within the range shown below.

• **Vertical direction**

The projector may be installed at a vertical angle of 360°.

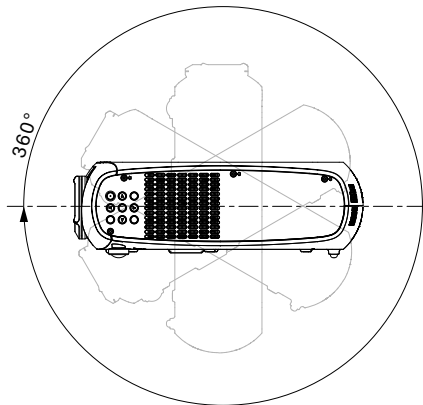

• **Horizontal direction**

The projector may be installed at a horizontal angle of ±210°.

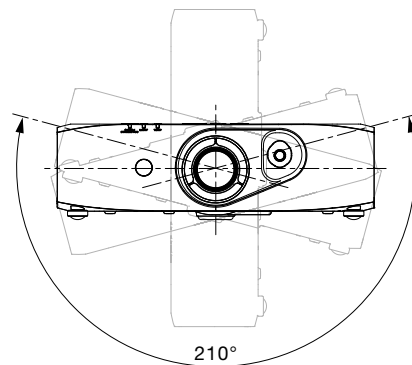

List of compatible signals

The signals that can be input to this projector are shown in the table below. Horizontal scanning frequencies of 15 kHz to 100 kHz, vertical scanning frequencies of 24 Hz to 120 Hz, and a dot clock of 162 MHz maximum can be input.

NOTE: The native resolution of this projector is 1,280 × 800 pixels. If the display resolution of the input signal is different from the native resolution, image compression or expansion will be used to convert the input signal to a level within the native resolution.

Display mode	Display resolution (dots)*1	Scanning frequency		Dot clock frequency (MHz)	Format
		H (kHz)	V (Hz)		
NTSC/NTSC4.43/PAL-M/PAL60	720 × 480i	15.7	59.9	–	VIDEO/S-VIDEO
PAL/PAL-N/SECAM	720 × 576i	15.6	50.0	–	
480i (525i)	720 × 480i	15.7	59.9	13.5	YPbPr/
576i (625i)	720 × 576i	15.6	50.0	13.5	COMPUTER (RGB)
480p (525p)	720 × 483	31.5	59.9	27.0	HDMI/DVI/
576p (625p)	720 × 576	31.3	50.0	27.0	COMPUTER (RGB)/
720 (750)p/60p	1,280 × 720	45.0	60.0	74.3	YPbPr
720 (750)p/50p		37.5	50.0	74.3	
1035 (1125)/60i	1,920 × 1,035i	33.8	60.0	74.3	
1080 (1125)/60i	1,920 × 1,080i	33.8	60.0	74.3	
1080 (1125)/50i		28.1	50.0	74.3	
1080 (1125)/24p	1,920 × 1,080	27.0	24.0	74.3	
1080 (1125)/24sF	1,920 × 1,080i	27.0	24.0	74.3	
1080 (1125)/25p		28.1	25.0	74.3	
1080 (1125)/30p	1,920 × 1,080	33.8	30.0	74.3	
1080 (1125)/60p		67.5	60.0	148.5	
1080 (1125)/50p		56.3	50.0	148.5	
VGA400	640 × 400	31.5	70.1	25.2	HDMI/DVI/
		37.9	85.1	31.5	COMPUTER (RGB)
VGA	640 × 480	31.5	59.9	25.2	
		35.0	66.7	30.2	
		37.5	75.0	31.5	
		37.9	72.8	31.5	
		43.3	85.0	36.0	
SVGA	800 × 600	35.2	56.3	36.0	
		37.9	60.3	40.0	
		48.1	72.2	50.0	
		46.9	75.0	49.5	
		53.7	85.1	56.3	
MAC16	832 × 624	49.7	74.6	57.3	
XGA	1,024 × 768	39.6	50.0	51.9	
		48.4	60.0	65.0	
		56.5	70.1	75.0	
		60.0	75.0	78.8	
		65.5	81.6	86.0	
		68.7	85.0	94.5	
		80.0	100.0	105.0	
		99.0	119.8	137.8	
MXGA	1,152 × 864	64.0	70.0	94.2	
		67.5	74.9	108.0	
		77.1	85.0	119.7	
MAC21	1,152 × 870	68.7	75.1	100.0	
1280 × 720	1,280 × 720	37.1	49.8	60.5	
		44.8	59.9	74.5	
1280 × 768	1,280 × 768	39.6	49.9	65.3	
		47.8	59.9	79.5	
1280 × 800	1,280 × 800	41.3	50.0	68.0	
		49.7	59.8	83.5	
MSXGA	1,280 × 960	55.9	59.9	106.5	
SXGA	1,280 × 1,024	64.0	60.0	108.0	
		80.0	75.0	135.0	
		91.1	85.0	157.5	
SXGA+	1,400 × 1,050	65.2	60.0	122.6	
		65.3	60.0	121.8	
		82.2	75.0	155.9	
WXGA+	1,440 × 900	60.0	60.0	108.0	
UXGA	1,600 × 1,200	75.0	60.0	162.0	
WSXGA+	1,680 × 1,050	65.3	60.0	146.3	
1920 × 1080*2	1,920 × 1,080	66.6	59.9	138.5	
WUXGA*2	1,920 × 1,200	74.0	60.0	154.0	

1. The "i" appearing after the resolution indicates an interlaced signal.

2. Compliant with VESA CMT-RB (Coordinated Video Timing-Reduced Blanking).

NOTE: Compatible signals for DIGITAL LINK input are the same as compatible signals for HDMI input.

List of compatible 3D signals

The 3D signals that can be input to this projector are shown in the table below.

Display mode	Display resolution (dots)	Scanning frequency		Dot clock frequency (MHz)	HDMI			DVI-I			Computer
		H (kHz)	V (Hz)		Frame packing	Side by side*1	Top and bottom	Side by side*1	Top and bottom	Frame sequential*2	Frame sequential
750 (720)p/60p	1280 × 720	45.0	60.0	74.3	√*3	√	√*3	(√)*4	(√)*5	-	-
750 (720)p/50p		37.5	50.0		√*3	(√)*4	√*3	(√)*4	(√)*5	-	-
1125 (1080)/60i	1920 × 1080i	33.8	60.0		-	√*3	-	(√)*4	-	-	-
1125 (1080)/50i		28.1	50.0		-	√*3	-	(√)*4	-	-	-
1125 (1080)/24p	1920 × 1080	27.0	24.0		√*3	√	√*3	(√)*4	(√)*5	-	-
1125 (1080)/60p	1920 × 1080	67.5	60.0	148.5	-	√	-	(√)*4	-	-	-
1125 (1080)/50p		56.3	50.0		-	(√)*4	-	(√)*4	-	-	-
XGA	1024 × 768	80.0	100.0	105.0	-	-	-	-	-	(√)*6	(√)*6
		99.0	119.8	137.8	-	-	-	-	-	(√)*6	(√)*6
1280 × 720	1280 × 720	92.6	120.0	161.6	-	-	-	-	-	(√)*6	(√)*6

- *1 Only DVI digital signals are compatible.
- *2 DVI digital signals and DVI analog signals are compatible.
- *3 A 3D mandatory format for the HDMI standard.
- *4 3D images can be displayed by setting the "3D INPUT FORMAT" to "SIDE BY SIDE."
- *5 3D images can be displayed by setting the "3D INPUT FORMAT" to "TOP AND BOTTOM."
- *6 3D images can be displayed by setting the "3D INPUT FORMAT" to "FRAME SEQUENTIAL."

NOTE: Compatible 3D signals for DIGITAL LINK input are the same as compatible signals for HDMI input.

Serial connector

The serial connector complies with RS-232C. To control the projector from a personal computer, commands must be input through communication software, based on the format and satisfying the communication conditions shown below.

Pin assignments and signal names

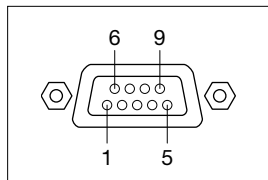

No.	Signal name	Description	No.	Signal name	Description
1	-	NC	6	-	NC
2	TXD	Send data	7	CTS	Connected internally
3	RXD	Receive data	8	RTS	Connected internally
4	-	Connected internally	9	-	NC
5	GND	Ground			

D-sub 9-pin (female) Serial input

Communication conditions (factory setting)

Signal level	RS-232C-compliant
Synchronization method	Start-stop synchronization
Baud rate	9,600 bps
Parity	None
Character length	8 bits
Stop bit	1 bit
X parameter	None
S parameter	None

Basic format

Transmission from the computer begins with STX, then the ID, command, parameter, and ETX are sent in this order. Add parameters according to the details of control.

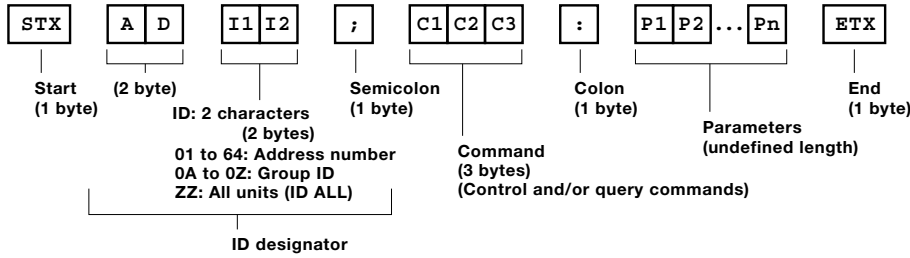

CAUTION

- It may not be possible that responses would delay or commands cannot be executed when commands are sent soon after the light source is turned on. If this occurs, wait for 60 seconds, then try sending or receiving again.
- When sending multiple commands, be sure to wait for at least 0.5 second after receiving a response from the projector before sending the next command.
- Additional time is sometimes required for response due to processing inside the projector. Set the time-out period for command response to 10 seconds or more.
- When using two or more units, set different IDs for each unit.

Cable specifications

Projector		PC (DTE)	
1	NC	NC	1
2			2
3			3
4	NC	NC	4
5			5
6	NC	NC	6
7			7
8			8
9	NC	NC	9

Control commands

Command : Parameter	Function		Callback
PON	POWER (STANDBY)	On	PON
POF		Off	POF
IIS:DL1	INPUT SELECT	DIGITAL LINK	IIS:DL1
IIS:HD1		HDMI	IIS:HD1
IIS:DVI		DVI	IIS:DVI
IIS:RG1		COMPUTER	IIS:RG1
IIS:VID		VIDEO	IIS:VID
IIS:DL1:HD1	When DIGITAL LINK input is selected and input of the digital interface box ET-YFB100G is changed as well.	HDMI 1	IIS:DL1:HD1
IIS:DL1:HD2		HDMI 2	IIS:DL1:HD2
IIS:DL1:PC1		COMPUTER 1	IIS:DL1:PC1
IIS:DL1:PC2		COMPUTER 2	IIS:DL1:PC2
IIS:DL1:VID		VIDEO	IIS:DL1:VID
IIS:DL1:SVD		S-VIDEO	IIS:DL1:SVD
OSH:0	AV MUTE	Off	OSH:0
OSH:1		On	OSH:1
OFZ:0	FREEZE	Off	OFZ:0
OFZ:1		On	OFZ:1
OAS	AUTO SETUP		OAS
OLP:*	LIGHT SOURCE POWER	Normal	OLP:0
OLP:*		Eco Save 1	OLP:6
OLP:*		Eco Save 2	OLP:7
OLP:*		Low	OLP:1
VPM:NAT	PICTURE MODE	Natural	VPM:NAT
VPM:STD		Standard	VPM:STD
VPM:DYN		Dynamic	VPM:DYN
VPM:CIN		Cinema	VPM:CIN
VPM:GRA		Graphic	VPM:GRA
VPM:DIC		DICOM	VPM:DIC
VPM:709		Rec. 709	VPM:709
OTE:1	COLOR TEMPERATURE	Middle	OTE:1
OTE:2		High	OTE:2
OTE:4		User	OTE:4
OTE:10		Default	OTE:10
TSD:y1y2y3y4m1m2d1d2w	DATE	Date setting	TSD:y1y2y3y4m1m2d1d2w
TST:h1h2m1m2s1s2	TIME	Time setting	TST:h1h2m1m2s1s2
OOS:0	ON SCREEN	On-screen display off	OOS:0
OOS:1		On-screen display on	OOS:1

* When a command that cannot be executed during standby mode is sent, the projector will send an ER401 command in reply.

Status request commands

Command:Parameter	Function	Callback	Description
QPW	Standby power status	000	Off
		001	On
QIN	Input signal status	DL1	DIGITAL LINK
		HD1	HDMI
		DVI	DVI
		RG1	RGB 1
		RG2	RGB 2
		VID	VIDEO
	Input signal status of the digital interface box ET-YFB100G when DIGITAL LINK input is selected.	DL1*HD1	HDMI 1
		DL1*HD2	HDMI 2
		DL1*PC1	COMPUTER 1
		DL1*PC2	COMPUTER 2
QSH	AV mute status	0	Off
		1	On
QFZ	Freeze function status	0	Off
		1	On
QOS	On-screen display status	0	Off
		1	On
QST	Projector run time	p1p2p3p4p5	00000h~99999h
QLP	Light source power mode status	OLP:0	Normal
		OLP:6	Eco Save 1
		OLP:7	Eco Save 2
		OLP:1	Low
QPM	Picture mode status	NAT	Natural
		STD	Standard
		DYN	Dynamic
		CIN	Cinema
		GRA	Graphic
		DIC	DICOM
		709	Rec. 709
QTM:0	Temperature status	p1p2p3p4/p5p6p7p8 (*1)	Intake
QTM:2		Optical module	
QTM:3		Inside	
QTM:4		Light source (Red)	
QTM:5		Light source (Green)	
QTM:6		Light source (Blue)	
QGD	Date setting status	y1y2y3y4m1m2d1d2w	yyyymmdd (day of week) (*2)
QGT	Time setting status	h1h2m1m2s1s2	hhmmss

*1 p1p2p3p4: Celsius (°C), p5p6p7p8: Fahrenheit (°F)
 *2 Day of week: Monday = 1, Tuesday = 2, ... Sunday = 7

NOTE: If a wrong command is received, the projector will send an ER401 or ER402 command to the computer.

Command example

To set the on-screen display off, send the command as shown below.



NOTE: When sending commands without parameters, a colon (:) is not necessary.

Notes on projector placement and operation

Please observe the following precautions for projector placement and operation.

1. Never place objects on top of the projector while it is operating.
2. Make sure there is an unobstructed space of 500 mm (1 foot 8 inches) or more around the projector's exhaust openings.
3. Do not stack projector units directly on top of one another for the purpose of multiple (stacked) projection. When stacking projector units, be sure to provide the amount of space indicated below between them. These space requirements also apply to installations where only one projector unit is operating at one time and the other unit is used as a backup.
4. Make sure that nothing blocks the projector's air intake and exhaust openings. Also, install the projector so that cool or hot air from other air conditioning equipment does not flow directly toward the projector's air intake or exhaust openings.
5. Do not install the projector in an enclosed space. If it is necessary to install it in an enclosed space, add a separate ventilation system. If ventilation is insufficient, hot air will accumulate at the intake opening. This may cause the projector's protective circuit to interrupt projector operation.
6. If the projector is placed in a box, ensure that the projector's intake and exhaust openings are not blocked. Take particular care to ensure that hot air from the exhaust openings is not sucked into the intake openings.
7. To install and use the projector via a method that does not use the adjustable feet in a floor standing installation, fix the projector using the four screw holes for ceiling mounting. (Screw diameter: M4, tapping depth inside the set: 10 mm, torque: 1.25 ± 0.2 N·m)

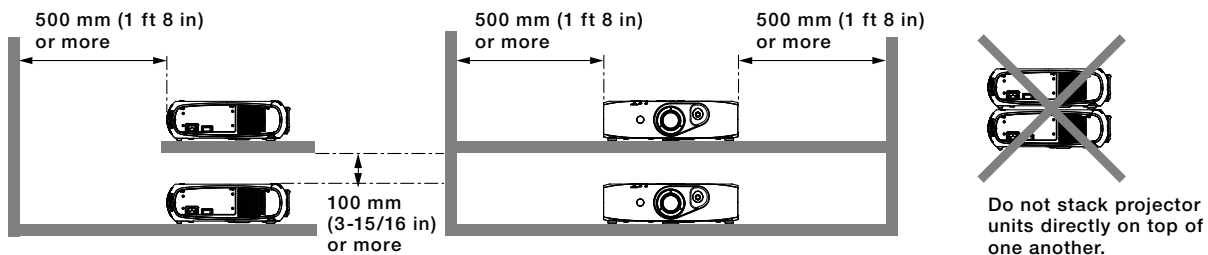

Direction of air intake and exhaust

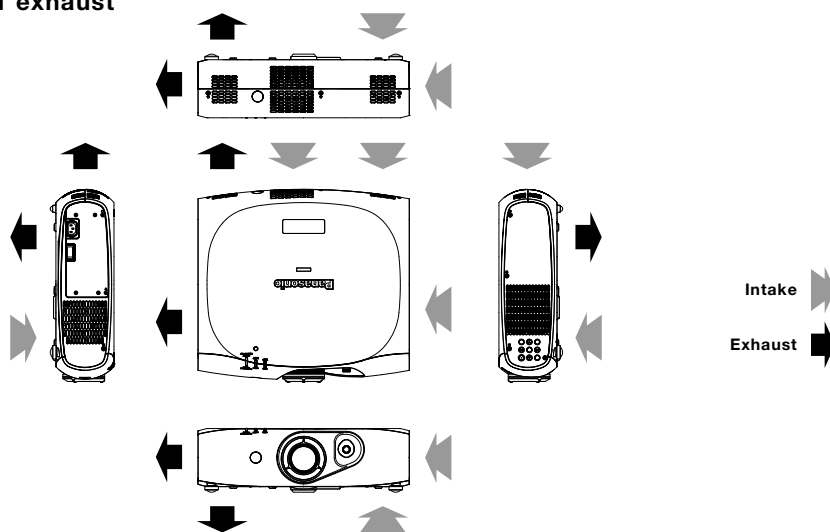

Weights and dimensions shown are approximate. Specifications and appearance are subject to change without notice. Product availability differs depending on region and country. This product may be subject to export control regulations.

DLP and the DLP logo are trademarks of Texas Instruments.
 PJLink is a registered trademark, or a trademark application has been filed, in Japan, the United States, and other countries and regions.
 All other trademarks are the property of their respective trademark owners.