

The
POWER *In*
PRESENTATION PRODUCTS



**Instruction Book for
BOARDROOM ELECTROL®**



DA-LITE SCREEN COMPANY, INC.

3100 North Detroit Street
Post Office Box 137
Warsaw, Indiana 46581-0137
Phone: 574-267-8101
800-622-3737
Fax: 574-267-7804
Toll Free Fax: 877-325-4832
www.da-lite.com
e-mail: info@da-lite.com

IMPORTANT SAFETY INSTRUCTIONS

When using your video equipment, basic safety precautions should always be followed, including the following:

1. Read and understand all instructions before using.
2. Position the cord so that it will not be tripped over, pulled, or contact hot surfaces.
3. If an extension cord is necessary, a cord with a current rating at least equal to that of the appliance should be used. Cords rated for less amperage than the appliance may over-heat.
4. To reduce the risk of electric shock, do not disassemble this appliance. Contact an authorized service dealer when repair work is required. Incorrect reassembly can cause electric shock when the appliance is used subsequently.
5. The use of an accessory attachment not recommended by the manufacturer may cause a risk of fire, electric shock, or injury to persons.

SAVE THESE INSTRUCTIONS

PRE-INSTALLATION

1. Carefully unpack screen and remove outer wrapping from case.
2. Make sure to recheck measurement of screen location before installation.
3. Remove center support brackets (on 8' and wider screens only), reverse brackets and reinstall flush with the top of the box.

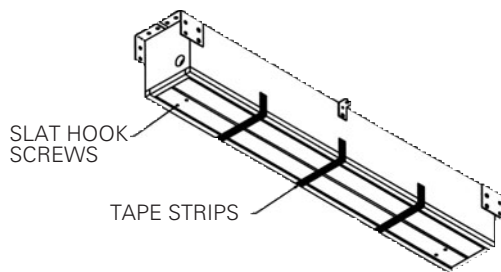

FIGURE 1

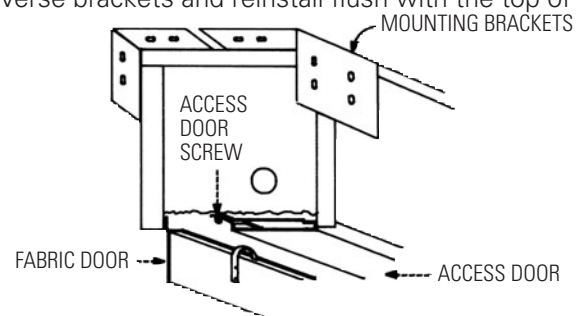

FIGURE 2

INSTALLATION

1. Install screen by raising unit into position between joists at one end only. Install one lag screw or appropriate fastener in each mounting bracket. Secure opposite end. Secure center support brackets. Install sufficient fasteners in each bracket for secure installation.
2. Make sure unit is level and plumb.

CAUTION! Do not secure access door or seal in unit until screen has been secured in position and properly tested for satisfactory operation. Do not fit unit so tightly that the screen surface drop door binds. Door drops by gravity only.

3. If you are going to cover screen door with paneling or other materials, allow access (suitable holes or plug) to slat hook screws (4) when servicing (Fig. 1).
4. Open access door by removing access door screws.
5. Remove junction box cover plate.

BOARDROOM ELECTROL® INSTALLATION

6. Install electrical hook up that applies to your unit. Make sure to review your wiring diagram for either 120 volt switch, 220/240 volt switch, or low voltage control.

NOTE: Screen has been internally wired at DA-LITE. Wiring designated "external" is completed by installer conforming to local and national codes.

7. Lower picture surface approximately 4"-6" so that the slat will rest on top of the slat hooks. Gently lift slat up and ease it under the slat hooks (Fig. 3).

NOTE: Do not allow slat to become obstructed on door closing hooks attached to surface door. When rolled down, the picture surface should wrap fully around the roller. No part of the roller should be exposed. Picture surface will automatically stop in the down position.

8. Test installation by carefully running picture surface up and down 2-3 times. Be prepared to stop screen.
9. Run the picture surface upward. The surface door will automatically close when the picture surface rolls into the case. The ends of the slat will catch the two hooks on the surface door and pull the door closed. When the door closes, a limit switch is tripped and the motor shuts off.



CAUTION! Excessive continuous operation may cause overheating.

10. Run picture surface downward until picture surface door fully opens.
11. Install junction box cover plate.
12. Close access door and reinstall screws at each end of access door.



CAUTION! Do not attempt to restore a lost wrap by adjusting limit switches. Allow one-eighth of an inch (1/8") clearance around surface door. Make sure door does not bind. Check hinges. Paint or tile cement will interfere with free operation. Gravity drops door.

13. Complete installation by painting and finishing to suit your needs. Finish to allow access door to be removed if necessary.

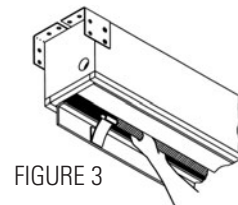
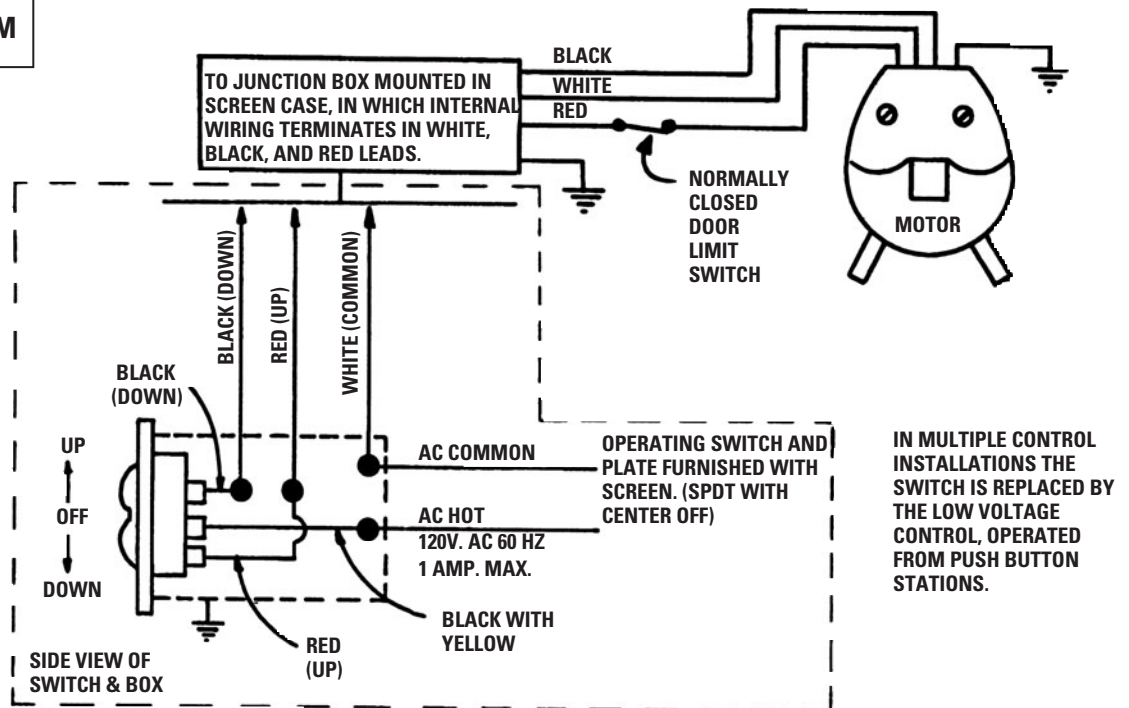

FIGURE 3

BOARDROOM ELECTROL® INSTALLATION 120V SCREENS

120V WIRING DIAGRAM



IN MULTIPLE CONTROL INSTALLATIONS THE SWITCH IS REPLACED BY THE LOW VOLTAGE CONTROL, OPERATED FROM PUSH BUTTON STATIONS.

THIS SWITCH CANNOT BE USED WITH L.V.C.

NOTE: A SINGLE SWITCH CANNOT BE USED TO OPERATE MORE THAN ONE SCREEN. CONTACT THE FACTORY FOR FURTHER INFORMATION.

SCREEN ADJUSTMENT FOR 120V SCREENS

Surface travel is stopped automatically in the fully opened and closed positions by limit switches that are properly adjusted at Da-Lite. Should it be necessary to adjust for more or less drop of picture, proceed in the following manner:

NOTE: Use a screw driver or 5/32" allen wrench to make adjustments.

MORE SCREEN DROP

1. Place operating switch in "down" position.
2. When the screen stops, turn the white "down" limit knob (Fig.4) one-quarter turn counterclockwise. Test by raising picture surface approximately two feet, then lower again. Repeat until desired picture surface position is attained.

LESS SCREEN DROP

1. Raise picture surface approximately two feet above desired level.
2. Place operating switch in "off" position.
3. Turn the white "down" limit knob (Fig.4) one-quarter turn clockwise. Test by raising picture surface approximately two feet, then lower again. Repeat until desired picture surface position is attained.

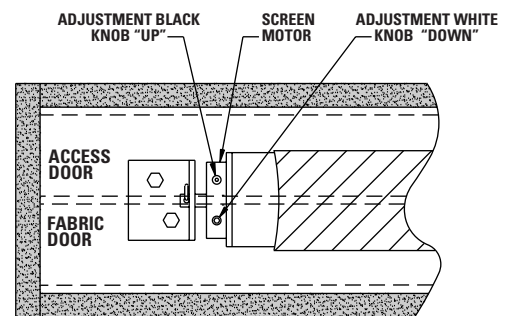
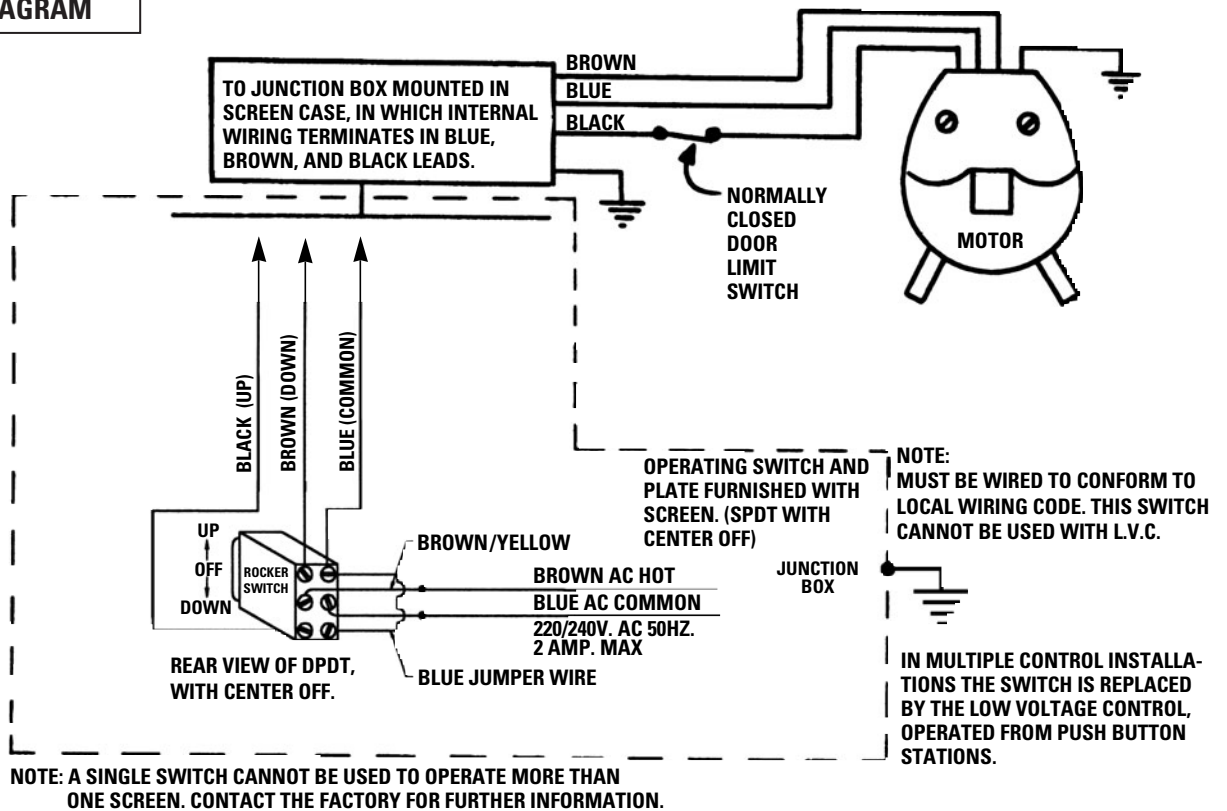

FIGURE 4

BOARDROOM ELECTROL® INSTALLATION 220/240V SCREENS

220 / 240V WIRING DIAGRAM



SCREEN ADJUSTMENT FOR 220/240V SCREENS

Surface travel is stopped automatically in the fully opened and closed positions by limit switches that are properly adjusted at Da-Lite. Should it be necessary to adjust for more or less drop of picture, proceed in the following manner:

NOTE: Use a screw driver or 5/32" allen wrench to make adjustments.

MORE SCREEN DROP

1. Place operating switch in "down" position.
2. When the screen stops, turn the white "down" limit knob (Fig.5) one-quarter turn counterclockwise. Test by raising picture surface approximately two feet, then lower again. Repeat until desired picture surface position is attained.

LESS SCREEN DROP

1. Raise picture surface approximately two feet above desired level.
2. Place operating switch in "off" position.
3. Turn the white "down" limit knob (Fig.5) one-quarter turn clockwise. Test by raising picture surface approximately two feet, then lower again. Repeat until desired picture surface position is attained.

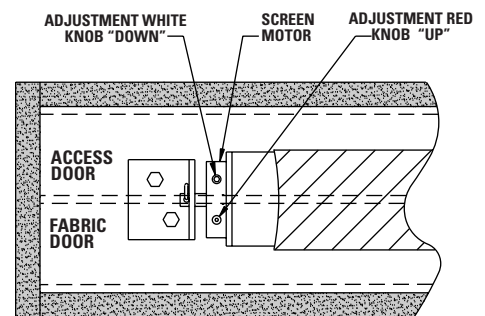
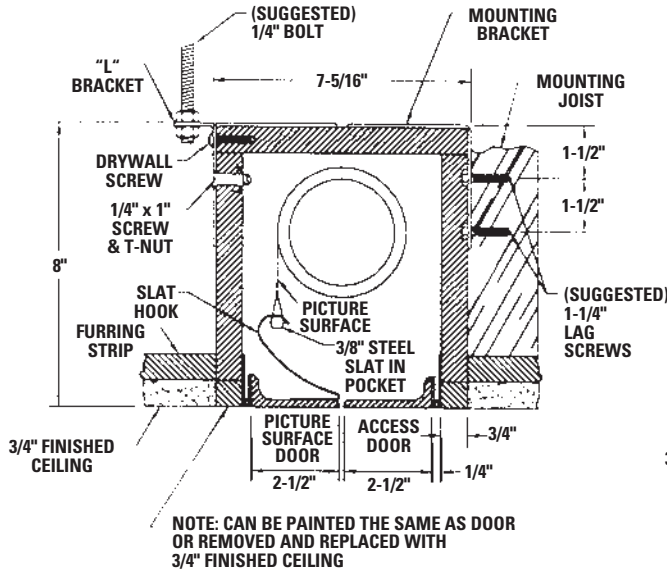

FIGURE 5

BOARDROOM ELECTROL® INSTALLATION

Select installation method according to ceiling type.

METHOD A



Offset mounting, recessed above ceiling. For plaster, dry wall, tile or paneling. Doors and bottom of case painted same finish as ceiling.

METHOD B

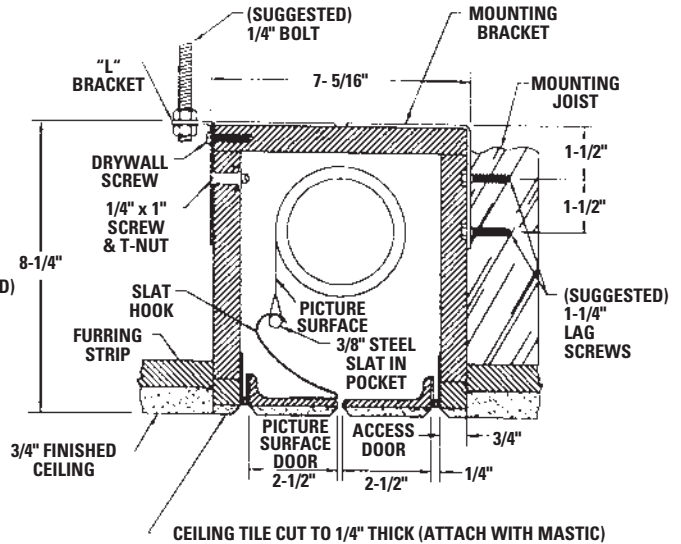

Offset mounting, recessed above ceiling. May be adapted for 3/4" ceiling, but cut to 1/4" thick under doors and screen case.

METHOD C

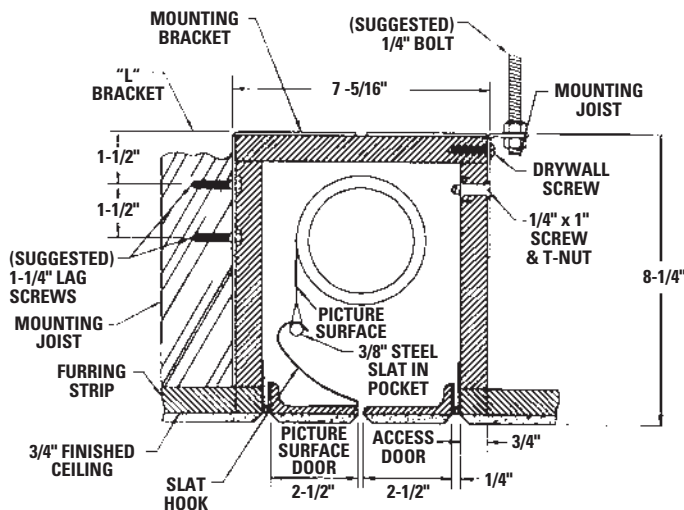

Flush mounting, recessed above ceiling. May be adapted for 1/4" paneling for ceiling and doors.

METHOD D

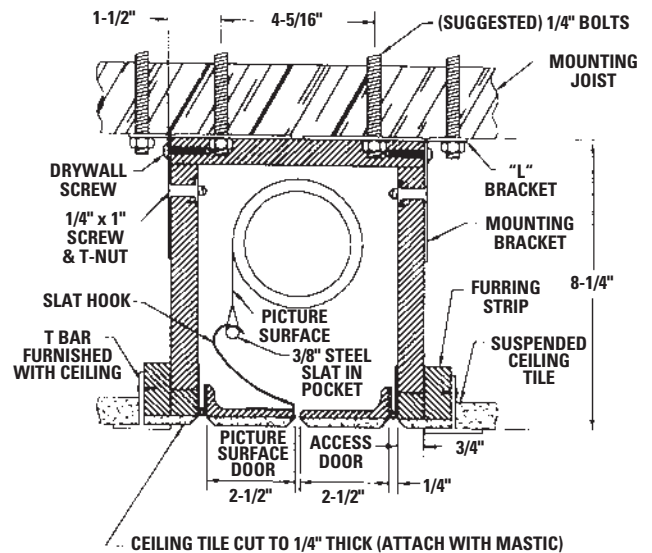

Flush mounting, recessed above ceiling. For use with dropped ceiling. May also be adapted for use with acoustical or other ceiling 3/4" thick but cut to 1/4" thick under doors and screen case.

TROUBLESHOOTING

SYMPTOM	CAUSE	SOLUTION
<p>1. Screen will not operate or will not go "down." Motor does not hum.</p> <p>Motor hums.</p>	<p>(a) Blown fuse.</p> <p>(b) Tripped circuit breaker.</p> <p>(c) No power to operating switch or junction box.</p> <p>(d) Insufficient line voltage (must be at least 115V or 220V, depending on motor type).</p> <p>Power at junction box</p> <p>(e) Thermal overload tripped.</p> <p>(f) Broken wire in the "down" position.</p> <p>(g) Defective motor, limit switch or capacitor.</p> <p>(h) Capacitor burned out.</p>	<p>(a) Replace fuse.</p> <p>(b) Reset circuit.</p> <p>(c) Check above. Tighten all loose wire connections. Recheck wiring. See installation instructions.</p> <p>(d) Correct line voltage.</p> <p>"Down" Position Check for power across black and white leads.</p> <p>(e) Let motor cool down for 15 minutes. Try again.</p> <p>(f) Check for continuity.</p> <p>(g) Replace motor assembly. NOTE: Motor is a sealed assembly.</p> <p>(h) Replace motor assembly.</p>
<p>2. Screen will not move upward. Motor does not hum.</p> <p>Motor hums.</p>	<p>(a) Blown fuse.</p> <p>(b) Tripped circuit breaker.</p> <p>(c) No power to operating switch or junction box.</p> <p>(d) Insufficient line voltage (must be at least 115V or 220V, depending on motor type).</p> <p>(e) Open door micro switch.</p> <p>Power at junction box</p> <p>(f) Thermal overload tripped.</p> <p>(g) Broken wire in the "up" position.</p> <p>(h) Defective motor, limit switch or capacitor.</p> <p>(i) Capacitor burned out.</p>	<p>(a) Replace fuse.</p> <p>(b) Reset circuit breaker.</p> <p>(c) Check above. Tighten all loose wire connections. See above.</p> <p>"Up" Position Check for power across red and white leads.</p> <p>(d) Correct line voltage.</p> <p>(e) Replace micro switch.</p> <p>(f) Let motor cool down for 15 minutes. Try again.</p> <p>(g) Check for continuity.</p> <p>(h) Replace motor assembly. NOTE: Motor is a sealed assembly.</p> <p>(i) Replace motor assembly.</p>
<p>3. Door will not open</p>	<p>(a) Hinge is bound or has a foreign substance on it which does not allow it to open by gravity.</p> <p>(b) Slat hooks catch on access door.</p>	<p>(a) Check installation to free door. Clear any foreign substance; i.e., paint or plaster from hinge.</p> <p>(b) Adjust slat hooks. Door can be opened by removing four screws holding slat hooks to door. Access should be provided to these screws during and after installation.</p>

TROUBLESHOOTING

SYMPTOM	CAUSE	SOLUTION
4. Door does not close tightly.	(a) "Up" limit switch in motor is out of adjustment.	(a) NOTE: This switch is not normally used when operating screen. Motor automatically shuts off if fabric does not close fabric door. If adjustment allows motor to shut off too soon, it will leave fabric door open. Adjust black limit switch clockwise (towards +).
5. "Down" limit switch incorrect.	(a) "Down" limit switch out of adjustment.	(a) See installation instructions.
6. Noise. NOTE: Screen will operate with a low-pitched hum.	(a) Squeaking, rubber end plug rubbing on motor. (b) Grinding. Foreign object in screen rubbing on roller or fabric. (c) Gear noise.	(a) Center roller in case. (b) Remove. (c) Replace motor assembly.
7. Coasting.	(a) Defective brake.	(a) Replace motor assembly.
8. Roller displaced from mounting bracket.	(a) Pin end slipped out of nylon bearing	(a) Remove pin end mounting. Realign motor in tube. Reattach pin end.
9. Fabric door hangs down on one end.	(a) Slat hooks not formed equally. (b) Crooked pocket.	(a) Bend slat hook slightly or apply tape to end of slat where door hangs. Build slat up enough to close door. (b) If not corrected by applying above, replace fabric.
10. Fabric hangs crooked or is rubbing on slat hook.	(a) Screen not installed properly. (b) Fabric has backed up inside case. (c) Fabric is damaged.	(a) Check for level and plumb. (b) Adjust "down" limit switch slowly until roller is exposed and wrinkle comes out, then readjust for proper drop. (c) Replace fabric.