

## ASSEMBLY

1. Attach the lower left (B) and right (C) end plates to the trim channel (A) using the 8-#10x3/4" screws (J).
2. Attach the upper left (D) and right (E) end plates to the screen end caps using the 5/16" x 3/4" bolts (I), 5/16 x 1-1/4" washers (F), split lock washers (H), and 5/16" nuts (G). Do not tighten the bolts at this time.
3. Attach the 4 straps (K) to the lower end plates using the 5/16 x 3/4" bolts (I), split lock washers (H), and 5/16" nuts (G). Use the first mounting hole on each strap to attach to the end plates. Do not tighten the bolts at this time.
4. Place the screen case on top of the trim channel (A) and align the holes in straps (K) with the holes in the upper end plates (D,E). Attach the straps to the upper end plates with 5/16" x 1/4" bolts (I), split lock washers (H), and 5/16" nuts (G). Do not tighten the bolts at this time.
5. Position the screen case so it is even on the trim channel. The straps should point straight up and be parallel with each other.
6. Tighten all the 5/16" bolts and nuts on each end of the screen case.
7. Lift the completed assembly into position in the ceiling and attach the straps to the building structure. The completed assembly should be positioned so the ceiling tiles or dry wall can be placed on top of the trim channel flange.
8. The ceiling tiles or dry wall can be positioned on the trim channel to complete installation.



**Assembly Instructions**  
for  
**COSMOPOLITAN®**  
**ELECTROL®**  
**CEILING TRIM KIT**



**DA-LITE SCREEN COMPANY, INC.**  
3100 North Detroit Street  
Post Office Box 137  
Warsaw, Indiana 46581-0137  
Phone: 574/267-8101  
800-622-3737  
Fax: 574/267-7804  
[http:// www.da-lite.com](http://www.da-lite.com)  
e-mail: [info@da-lite.com](mailto:info@da-lite.com)

## PARTS LIST

Before beginning assembly refer to the parts list diagram to become familiar with the different components.

**NOTE: The necessary fasteners are provided to assemble the trim kit and attach the screen case to the trim kit. The installer must provide fasteners to attach the completed assembly to the building structure.**

	QTY	DESCRIPTION
A	2	Trim Channel
B	1	End Plate, Lower Left
C	1	End Plate, Lower Right
D	1	End Plate, Upper Left
E	1	End Plate, Upper Right
F	2	Washer, 5/16" x 1-1/4"
G	16	Nut, 5/16"
H	16	Washer, Split Lock
I	16	Bolt, 5/16" x 3/4"
J	8	Screw, #10 x 3/4"
K	4	Strap

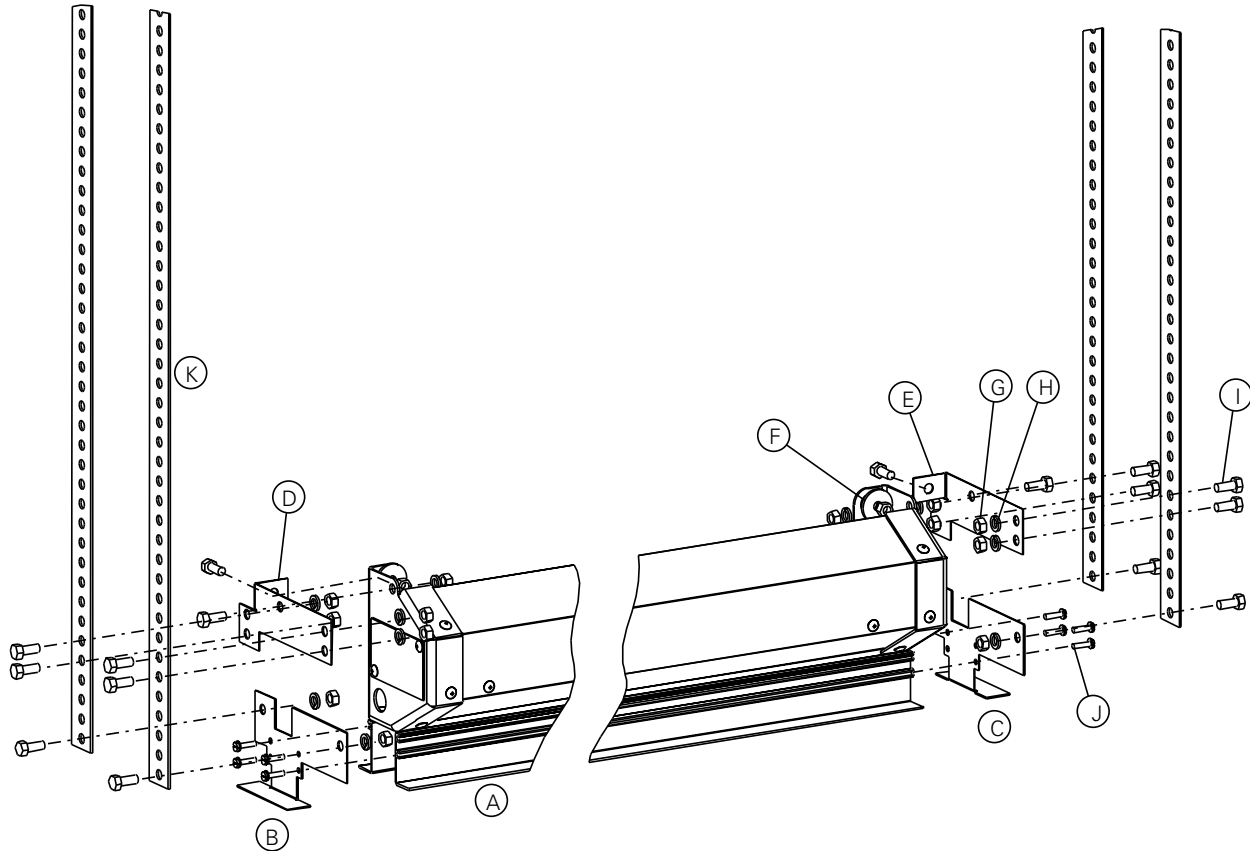

FIGURE 1