

The
POWER *In*
PRESENTATION PRODUCTS



**Instruction Book for
COSMOPOLITAN® ELECTROL®
For Sizes Up To 9'x12'**



DA-LITE SCREEN COMPANY, INC.

3100 North Detroit Street
Post Office Box 137
Warsaw, Indiana 46581-0137
Phone: 574-267-8101
800-622-3737
Fax: 574-267-7804
Toll Free Fax: 877-325-4832
www.da-lite.com
e-mail: info@da-lite.com

IMPORTANT SAFETY INSTRUCTIONS

When using your video equipment, basic safety precautions should always be followed, including the following:

1. Read and understand all instructions before using.
2. Position the cord so that it will not be tripped over, pulled, or contact hot surfaces.
3. If an extension cord is necessary, a cord with a current rating at least equal to that of the appliance should be used. Cords rated for less amperage than the appliance may overheat.
4. To reduce the risk of electric shock, do not disassemble this appliance. Contact an authorized service dealer when repair work is required. Incorrect reassembly can cause electric shock when the appliance is used subsequently.
5. The use of an accessory attachment not recommended by the manufacturer may cause a risk of fire, electric shock, or injury to persons.

SAVE THESE INSTRUCTIONS

PRE-INSTALLATION

1. Carefully unpack screen and remove outer wrapping from case.
2. Do not remove black tape or rubber bands from slat pocket.
3. Always handle screen in upright position.

INSTALLATION

There are three methods of mounting to include:

Flush against wall; Suspended from ceiling (use extension brackets); and Recessed above ceiling.

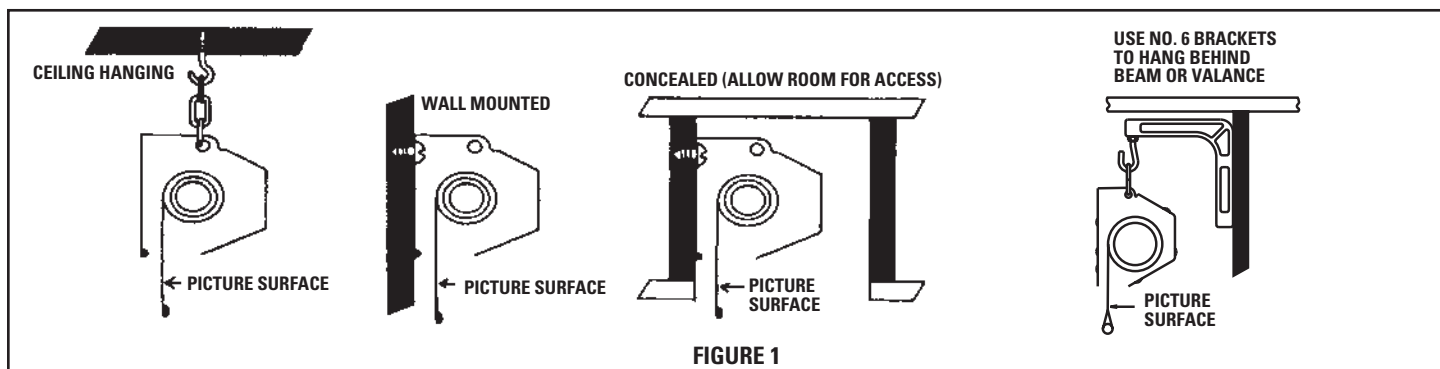

NOTE: Under no circumstances should unit be completely sealed in recessed installation. Allow access for service. Picture surface is centered in case. Case extends 4" beyond surface on either end. Do not attach anything to screen slat rod or bottom fabric pocket.

1. Make sure screen is level. Use a carpenter's level and plumb level.



CAUTION! Do not cut wrapping paper or tape with knife or any sharp tool. Remove by hand.

2. Remove tape and rubber bands from slat pocket.
3. Install electrical hook up that applies to your unit. Make sure to review your Electrical Installation Checklists and wiring diagrams (included) for either 120 volt switch, 220/240 volt switch, or low voltage control.

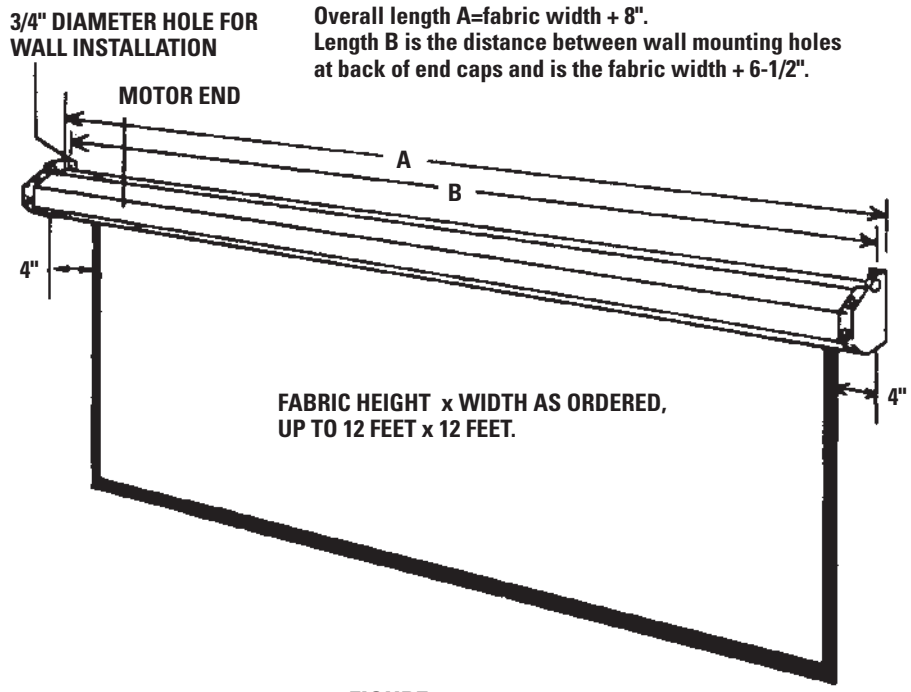
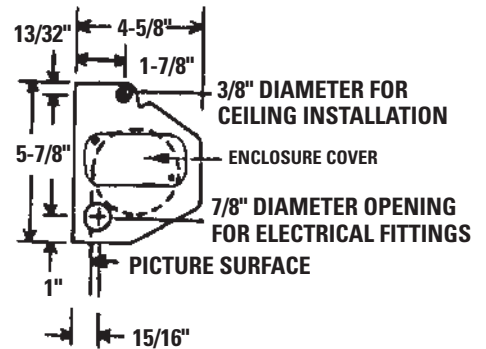

FIGURE 2



SCREEN ADJUSTMENT FOR 120V SCREENS WITHOUT A BUILT-IN LOW VOLTAGE CONTROL

Surface travel is stopped automatically in the fully opened and closed positions by limit switches that are properly adjusted at DA-LITE. Should it be necessary to adjust for more or less picture drop (viewing area), proceed in the following manner:

NOTE: Use a screwdriver or allen wrench to make adjustments.

SETTING THE DOWN LIMIT POSITION

TO REDUCE SCREEN DROP:

Turn the white limit switch screw clockwise to decrease the amount of screen drop. Run the screen down to test the stop position. If the screen drops too far, raise the screen about one foot and adjust the limit switch again. Repeat until the desired position is set.

TO INCREASE SCREEN DROP:

Turn the white limit switch screw counterclockwise to increase the amount of screen drop. Run the screen down to test the stop position. If the screen does not drop enough, raise the screen about one foot and adjust the limit switch again. Repeat until the desired position is set. Do not adjust for more drop than what was ordered. At least 1-1/2 wraps of fabric must remain on the roller.

SETTING THE UP LIMIT POSITION



CAUTION: Do not allow the slat bar to wrap over the top of the roller when the screen is rolling into the case. The screen could be damaged.

SCREEN TRAVELS INTO CASE TOO FAR:

Turn the black limit switch screw clockwise to decrease the amount of travel. Run the screen up to test the stop position. If the screen does not stop properly, lower the screen about one foot and turn the limit switch again. Repeat until the desired position is set.

SCREEN DOES NOT TRAVEL FAR ENOUGH INTO CASE:

Turn the black limit switch screw counterclockwise to increase the amount of up travel. Run the screen up to test the stop position. If more travel is desired, lower the screen about one foot and adjust the limit switch again. Repeat until the desired position is set.

COSMOPOLITAN® ELECTROL® INSTALLATION

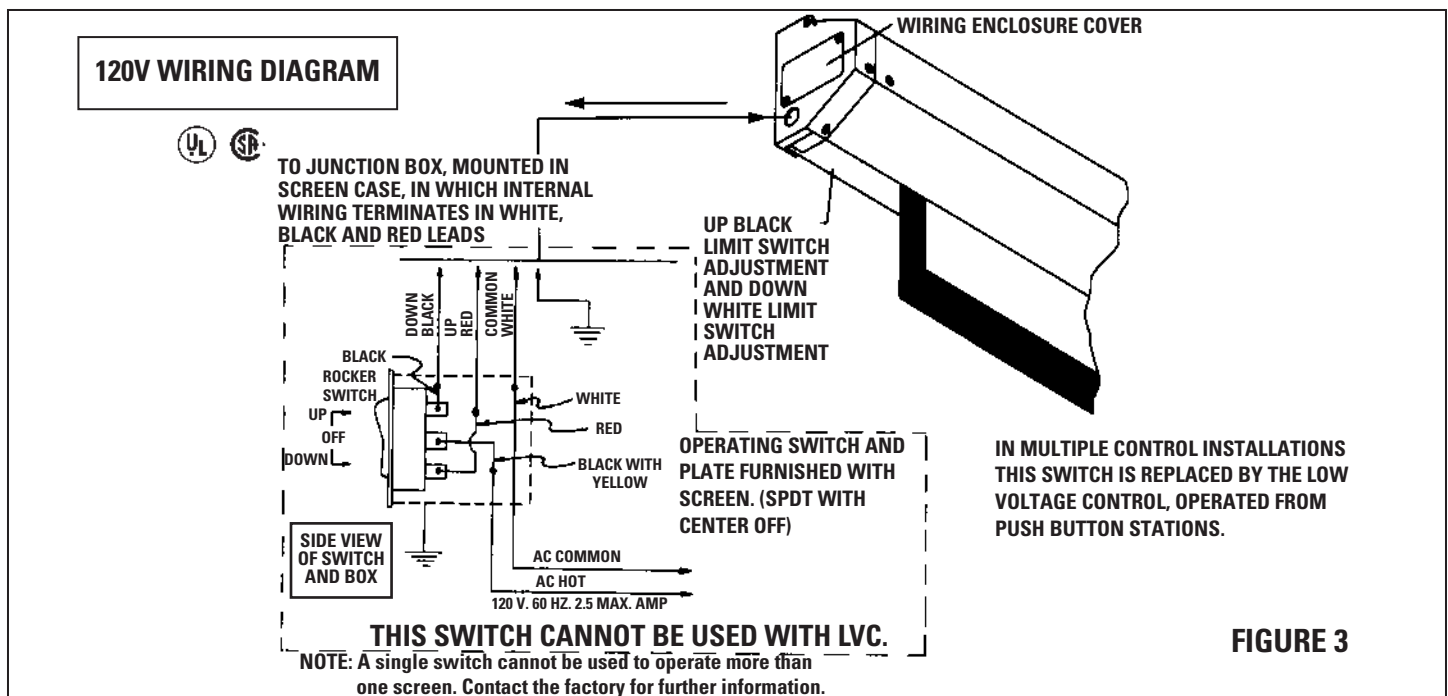

SCREEN ADJUSTMENT FOR 220/240V SCREENS WITHOUT A BUILT-IN LOW VOLTAGE CONTROL

Surface travel is stopped automatically in the fully opened and closed positions by limit switches that are properly adjusted at DA-LITE. Should it be necessary to adjust for more or less picture drop (viewing area), proceed in the following manner:

NOTE: Use a screwdriver or allen wrench to make adjustments.

SETTING THE DOWN LIMIT POSITION

TO REDUCE SCREEN DROP:

Turn the white limit switch screw clockwise to decrease the amount of screen drop. Run the screen down to test the stop position. If the screen drops too far, raise the screen about one foot and adjust the limit switch again. Repeat until the desired position is set.

TO INCREASE SCREEN DROP:

Turn the white limit switch screw counterclockwise to increase the amount of screen drop. Run the screen down to test the stop position. If the screen does not drop enough, raise the screen about one foot and adjust the limit switch again. Repeat until the desired position is set. Do not adjust for more drop than what was ordered. At least 1-1/2 wraps of fabric must remain on the roller.

SETTING THE UP LIMIT POSITION

CAUTION: Do not allow the slat bar to wrap over the top of the roller when the screen is rolling into the case. The screen could be damaged.

SCREEN TRAVELS INTO CASE TOO FAR:

Turn the red limit switch screw clockwise to decrease the amount of travel. Run the screen up to test the stop position. If the screen does not stop properly, lower the screen about one foot and turn the limit switch again. Repeat until the desired position is set.

SCREEN DOES NOT TRAVEL FAR ENOUGH INTO CASE:

Turn the red limit switch screw counterclockwise to increase the amount of up travel. Run the screen up to test the stop position. If more travel is desired, lower the screen about one foot and adjust the limit switch again. Repeat until the desired position is set.

COSMOPOLITAN® ELECTROL® INSTALLATION

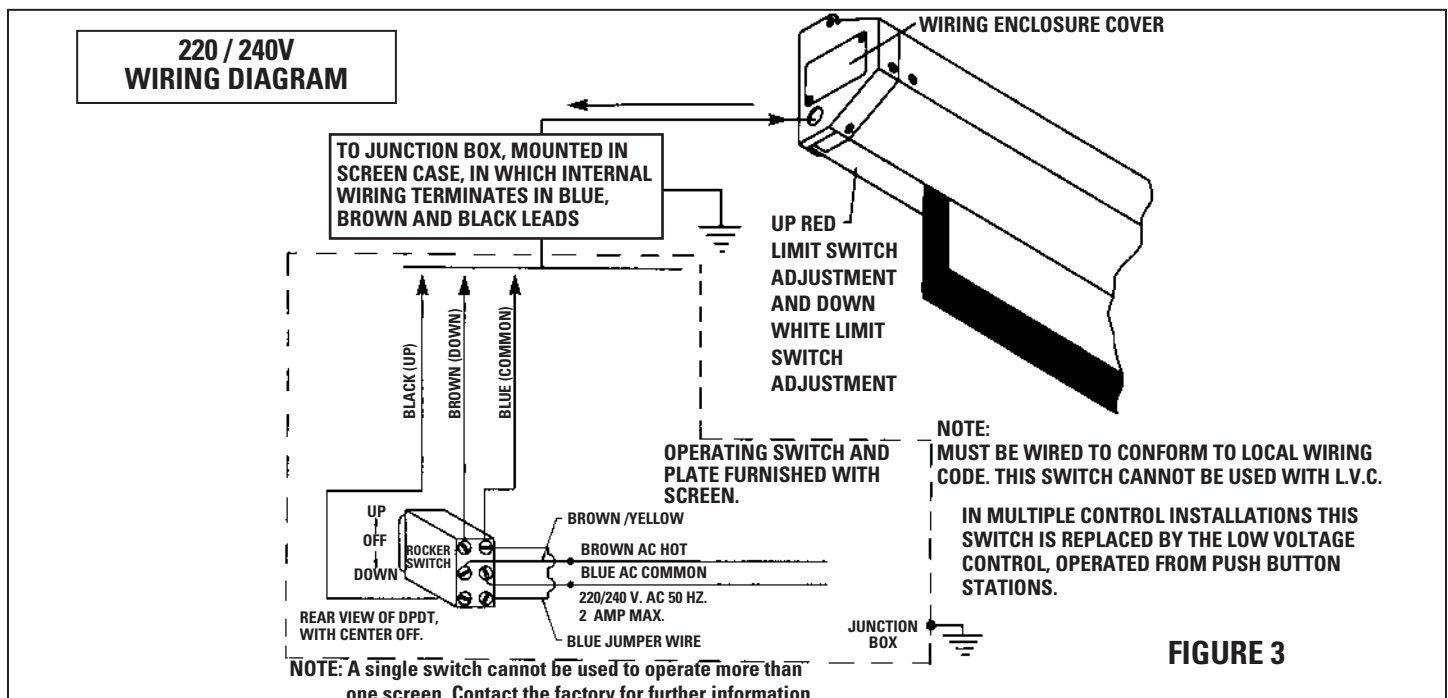

SCREEN ADJUSTMENT FOR SCREENS WITH A BUILT-IN LOW VOLTAGE CONTROL

1. Remove the cover plate from the 3-button wall switch and remove the switch from the junction box.
2. Locate small 3-position switch on back of wall switch. See Figure 4 for 120V screens or Figure 5 for 220/240V screens.
3. To adjust the down limit switch, slide the 3-position switch to the down position. Press and hold the down button to run the screen down to the desired stop position. Release the button to stop the screen. **DO NOT PUSH THE STOP BUTTON.**
4. When the screen is in the desired down position, slide the 3-position switch to the off (center) position. The down limit switch is now set.
5. To adjust the up limit switch, slide the 3-position switch to the up position. Press and hold the up button to run the screen up to the desired stop position. Release the button to stop the screen. **DO NOT PUSH THE STOP BUTTON.**
6. When the screen is in the desired up position, slide the 3-position switch to the off (center) position. The up limit switch is now set.
7. To test limit switch setting, make sure the 3-position switch is in the off (center) position. Press and release the up or down button on the wall switch to operate the screen.
8. Replace switch and cover plate on the wall.

NOTE: If stop button is pressed, the wall switch will reverse direction. To correct this, press the stop button again. This will reset the switch. You will have to re-set both the up and the down settings.

IMPORTANT NOTE: The wall switch is **REQUIRED** to make any limit switch adjustments, **EVEN** if a third party control system is used. Therefore, it is advised to wire the switch or provide a 4-conductor connection that is accessible.

120V WIRING DIAGRAM WITH OPTIONAL BUILT-IN LOW VOLTAGE CONTROL

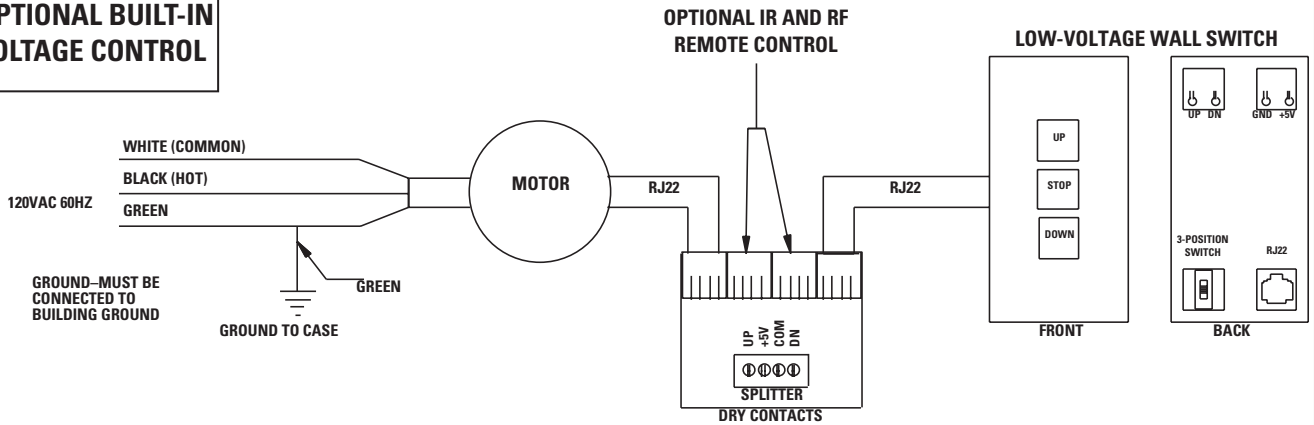

ILT RJ22 PIN-OUTS (TAB IS FACING UP)

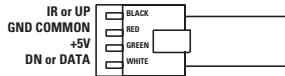

IMPORTANT NOTE: The wall switch is REQUIRED to make any limit switch adjustments, EVEN if a third party control system is used. Therefore, it is advised to wire the switch or provide a 4-conductor connection that is accessible.

FIGURE 4

240V WIRING DIAGRAM WITH OPTIONAL BUILT-IN LOW VOLTAGE CONTROL

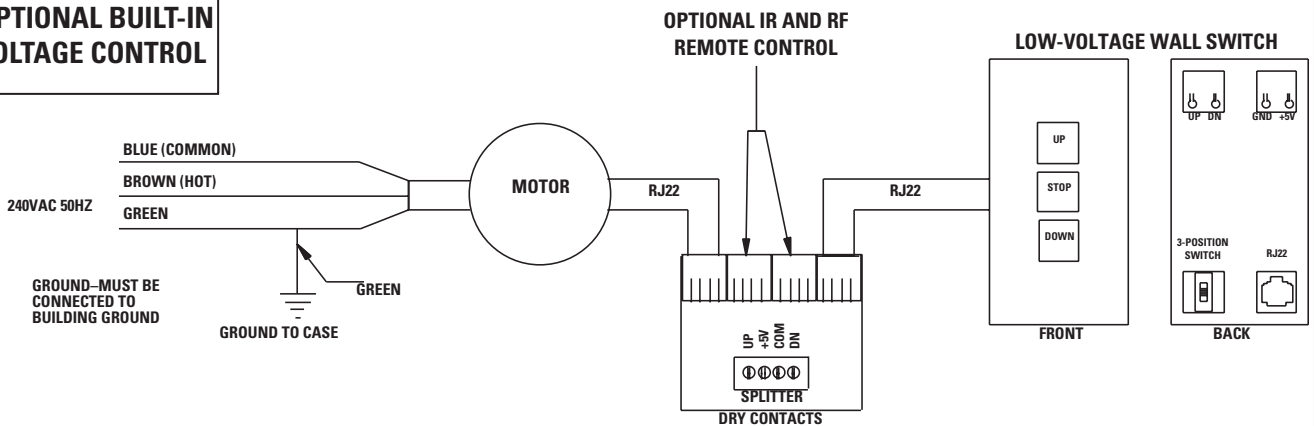

ILT RJ22 PIN-OUTS (TAB IS FACING UP)

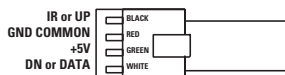

IMPORTANT NOTE: The wall switch is REQUIRED to make any limit switch adjustments, EVEN if a third party control system is used. Therefore, it is advised to wire the switch or provide a 4-conductor connection that is accessible.

FIGURE 5

TROUBLESHOOTING

SYMPTOM	CAUSE	SOLUTION
<p>1. Screen will not operate. Motor does not hum.</p> <p>Motor hums.</p>	<p>(a) Blown fuse. (b) Tripped circuit breaker. (c) No power to operating switch or junction.</p> <p>Power at junction box</p> <p>(d) Thermal overload tripped. (e) Broken wire in the "up" or "down" position. (f) Defective motor, limit switch or capacitor. (g) Temporary binding. (h) Capacitor burned out.</p>	<p>(a) Replace fuse. (b) Reset circuit breaker. (c) Check above. Tighten all loose wire connections. Correct any improper connections. "Down" Position Check for power across black and white leads. "Up" Position Check for power across red and white leads.</p> <p>(d) Let motor cool down for 15 minutes. Try again. (e) Check for continuity. Cut off old splice and reconnect. (f) Replace motor assembly. NOTE: Motor is a sealed assembly. (g) With power "off", turn roller by hand to free binding. (h) Replace motor assembly.</p>
2. Incorrect stopping position in downward direction.	<p>(a) Lost roller wrap. (b) "Down" limit switch out of adjustment</p>	<p>(a) See instructions below. (b) See installation instructions.</p>
3. Incorrect stopping position in upward direction.	<p>(a) Lost roller wrap. (b) "Up" limit switch out of adjustment</p>	<p>(a) See instructions below. (b) Adjust "up" limit switch. Turn clockwise to expose more fabric. See installation instructions</p>
4. Noise. NOTE: Screen will operate with a low pitched hum.	<p>(a) Squeaking rubber end plug rubbing on motor. (b) Grinding due to foreign object in screen rubbing on roller or fabric. (c) Gear noise.</p>	<p>(a) Adjust roller to center of case. (b) Remove foreign object. (c) Replace motor assembly.</p>
5. Coasting.	<p>(a) Defective brake.</p>	<p>(a) Replace motor assembly.</p>
6. Roller displaced from mounting bracket.	<p>(a) Pin end slipped out of nylon bearing.</p>	<p>(a) Remove pin end mounting. Re-align motor in tube. Re-attach pin end.</p>

RESTORING LOST ROLLER WRAP

1. Push strap over back of roller.
2. Tape end of strap to pocket.
3. Feed fabric as you pull strap to draw fabric over top.
4. Remove tape and strap.