

The
POWER *In*
PRESENTATION PRODUCTS



**Installation Instructions for
VIDEO PROJECTOR INTERFACE**



DA-LITE SCREEN COMPANY, INC.
3100 North Detroit Street
Post Office Box 137
Warsaw, Indiana 46581-0137
Phone: 574-267-8101
800-622-3737
Fax: 574-267-7804
www.da-lite.com
e-mail: info@da-lite.com

VIDEO PROJECTOR INTERFACE INSTALLATION

The Video Projector Interface (VPI) housing is divided into three compartments. The compartment labeled "Low Voltage Connections" is where you will connect the VPI to the projector's output. The compartment labeled "AC Power Connections" is where the main power, motor and wall switch wire connections are made. Access is not required to the center compartment.

WARNING: To prevent electrical shock or damage to the Video Projector Interface (VPI), do not apply power to the VPI until all connections are complete. Make sure power is turned off on all circuits before making connections.

LOW VOLTAGE CONNECTION

1. Use 2-conductor 20-24 gauge wire to extend the low voltage connection from the projector's 5 or 12-volt screen trigger output to the length required to reach the VPI. When extending the low voltage connection from the projector's screen trigger output, be sure to maintain the proper polarity. the red wire from the VPI is the "signal" and the black wire from the VPI is the "ground".
2. Connect the wires from the VPI that are labeled "Low Voltage Connection" to the end of the extended screen trigger wires above. See Figure 1.

CAUTION: NEVER APPLY MORE THAN 12 VOLTS DC TO THE PROJECTOR'S SCREEN TRIGGER WIRES OR THE VPI AND/OR PROJECTOR WILL BE DAMAGED.

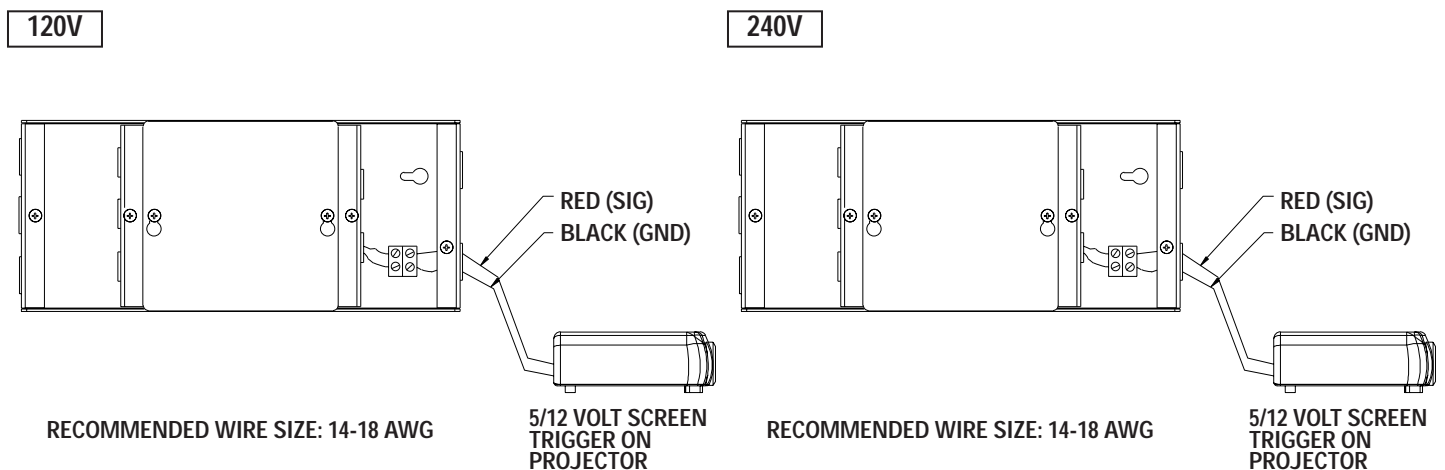

FIGURE 1

AC POWER CONNECTIONS

Screen Motor

1. Using 4-conductor, 14-18 gauge wire, extend the motor wires from the screen junction box to the length required to reach the VPI.
2. Connect the extended wires from the screen motor to the VPI wires that are labeled "motor wires". Refer to Figure 2.

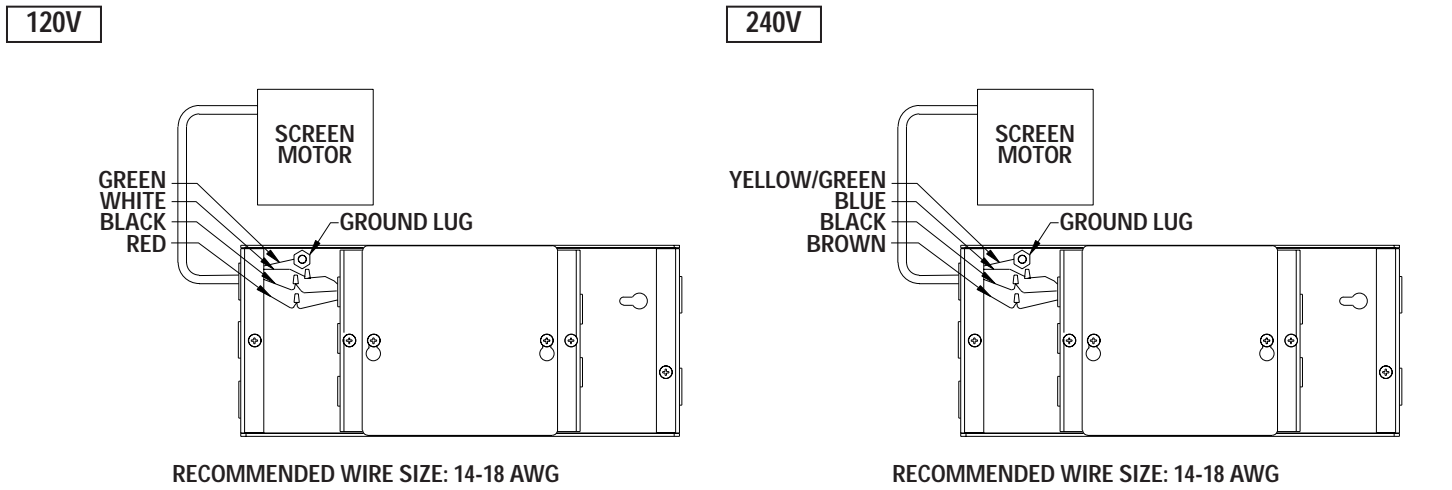

FIGURE 2

AC Power Source

1. Connect the incoming power wires to the VPI wires that are labeled "AC power input".
2. Connect the building ground wire to the ground lug on the metal housing. Refer to Figure 3.

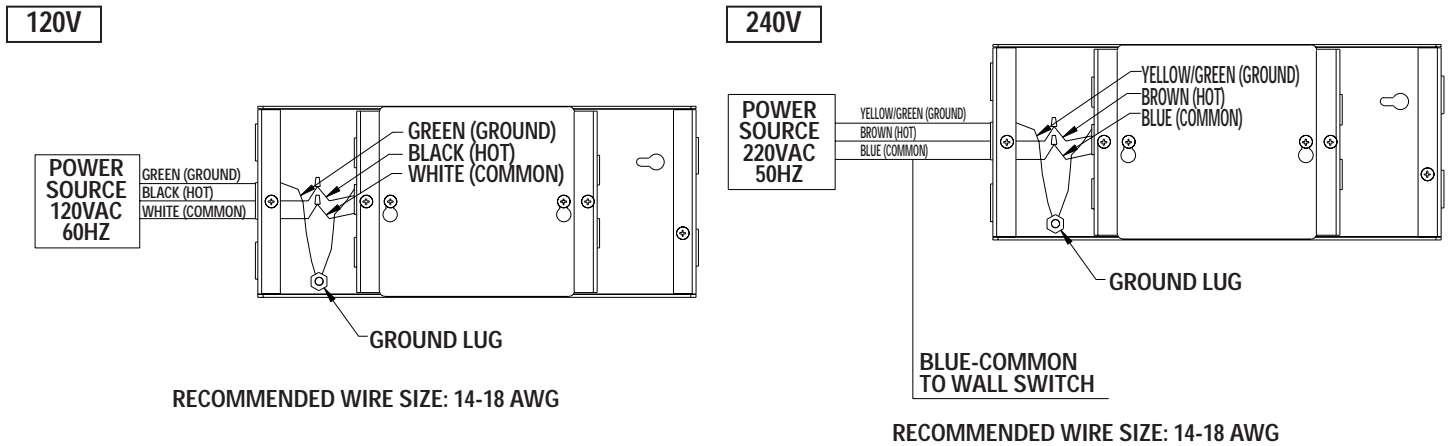

FIGURE 3

AC POWER CONNECTIONS

Wall Switch

1. Using 3-conductor, 14-18 gauge wire, extend the wall switch wires from the back of the wall switch to the length required to reach the VPI.
2. Connect the extended wires from the wall switch to the VPI wires that are labeled "wall switch". Refer to Figure 4.
3. The wall switch must be placed in the "up" position for the screen to be triggered by the projector.
4. If a wall switch is not being used, please do the following. For 120V units, the black/yellow lead and the red lead for the wall switch must be connected to each other and the black lead must be capped. For 240V units, the black/yellow lead and the black lead for the wall switch must be connected to each other and the brown lead must be capped.

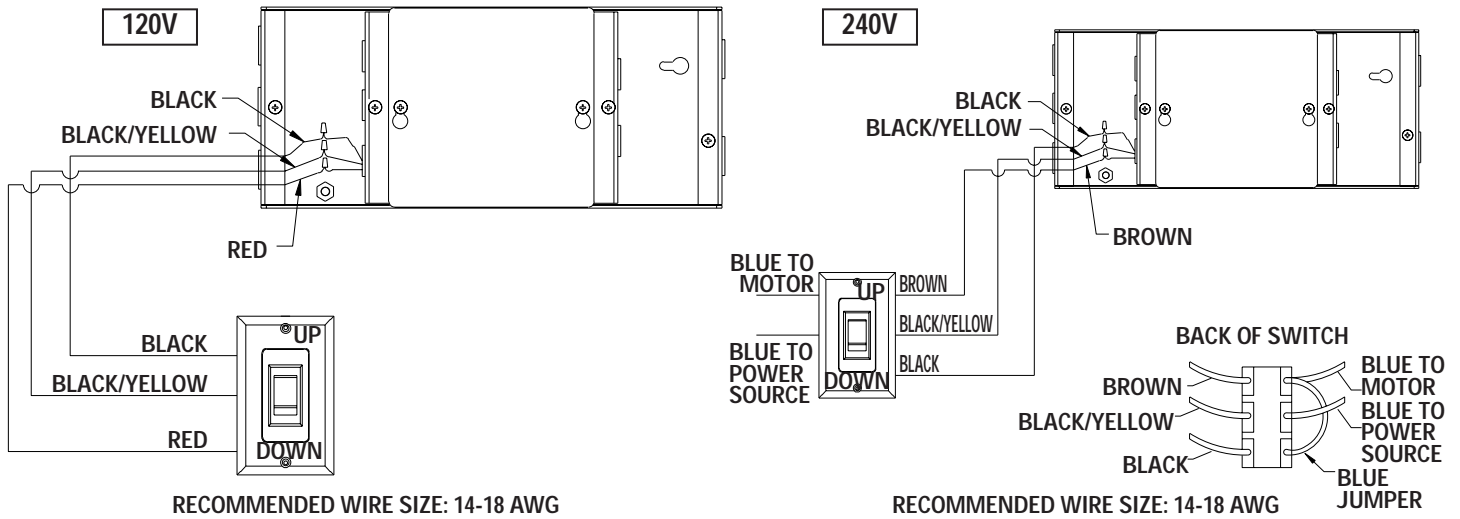

FIGURE 4