

The
POWER *In*
PRESENTATION PRODUCTS

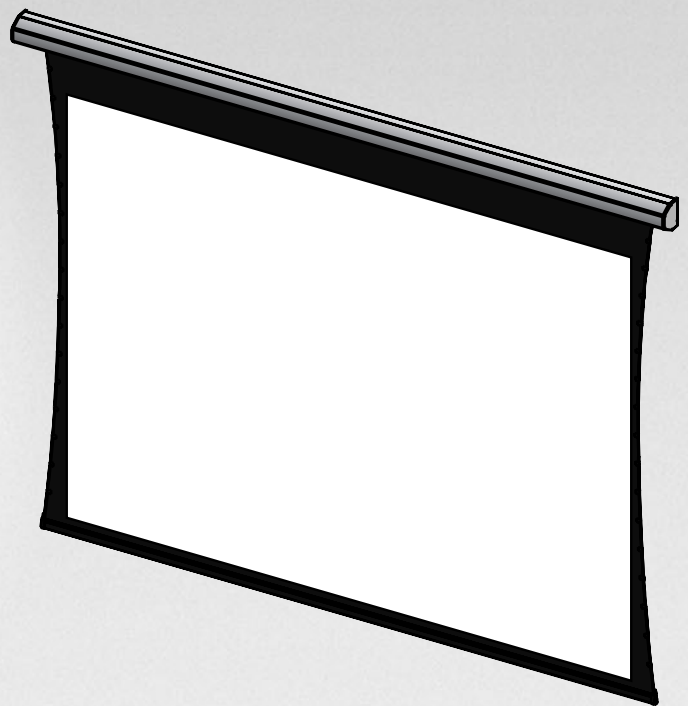

Instruction Book for
TENSIONED COSMOPOLITAN® ELECTROL®
9'x12', 180" Diagonal and Larger Sizes



DA-LITE SCREEN COMPANY, INC.

3100 North Detroit Street
Post Office Box 137
Warsaw, Indiana 46581-0137
Phone: 574-267-8101
800-622-3737
Fax: 574-267-7804
www.da-lite.com
e-mail: info@da-lite.com

IMPORTANT SAFETY INSTRUCTIONS

When using your video equipment, basic safety precautions should always be followed, including the following:

1. Read and understand all instructions before using.
2. Position the cord so that it will not be tripped over, pulled, or contact hot surfaces.
3. If an extension cord is necessary, a cord with a current rating at least equal to that of the appliance should be used. Cords rated for less amperage than the appliance may overheat.
4. To reduce the risk of electric shock, do not disassemble this appliance. Contact an authorized service dealer when repair work is required. Incorrect reassembly can cause electric shock when the appliance is used subsequently.
5. The use of an accessory attachment not recommended by the manufacturer may cause a risk of fire, electric shock, or injury to persons.

SAVE THESE INSTRUCTIONS

INSTALLATION

Carefully unpack screen and remove outer wrapping from case.

The slat retainer screws must be removed before installation. The slotted 1/4" hex screws fasten through the back of the case (at the bottom) into the slat bar. Orient the case with the slat down and then remove the screws. The case must remain in that orientation throughout the installation process to avoid fabric damage.

The Tensioned Cosmopolitan® Electrol® comes with brackets to allow for wall mount or ceiling mount installations. Procedures for each method are as follows:

Wall Mount

1. The wall mount bracket should be fastened to wall studs or some reinforcement within the wall. Concrete or brick walls require special fasteners and anchors.
2. The wall bracket has holes spaced at 16" and 24" to align with most wall studs.
3. The bracket must be level and plumb.
4. Keep in mind you will need at least 2-3/4" between the ceiling and the top of the wall mount bracket to be able to position the case on the bracket.
5. Mount the screen case on the wall bracket as shown in figure 1. Be sure the case is fully seated on the bracket. Tighten the stop screws against the wall bracket.

Ceiling Mount

1. Be sure the ceiling has adequate reinforcement to attach the screen brackets.
2. Attach the ceiling brackets to the wall mount bracket using the supplied 5/16" x 3/4" bolts, washers and nuts.
3. Position the ceiling bracket assembly on the ceiling and attach with 5/16" bolts (not supplied). The bolts should be long enough to pass through the drywall or ceiling tile and penetrate at least 1-1/2" into the reinforcement in the ceiling.
4. Mount the screen on the wall bracket as shown in figure 2. Be sure the case is fully seated on the bracket. Tighten the stop screws against the wall bracket.

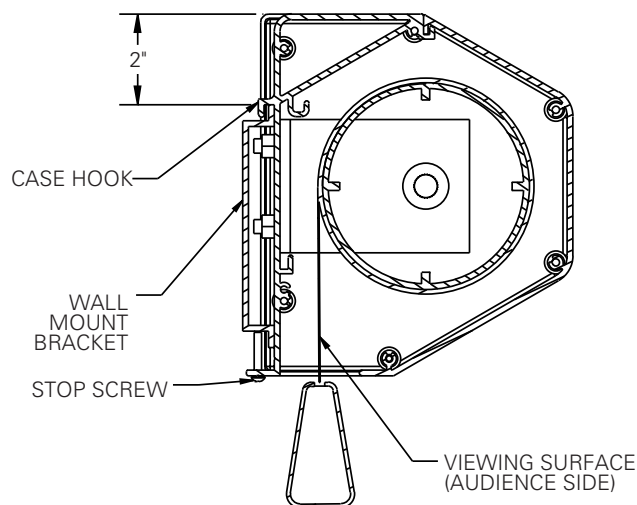

FIGURE 1

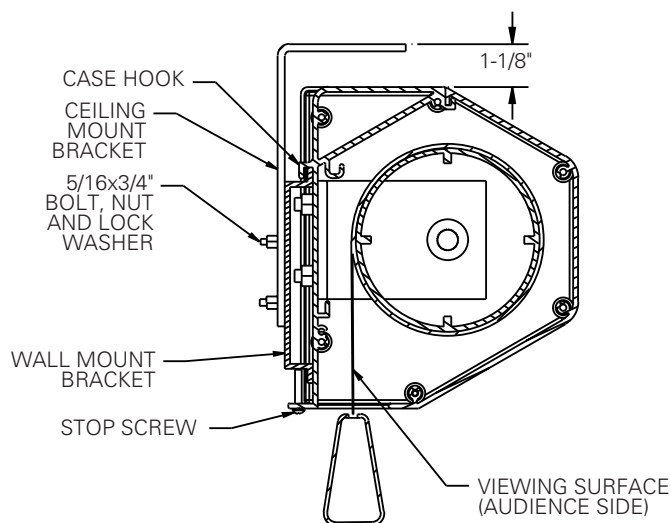

FIGURE 2

TENSIONED COSMOPOLITAN® ELECTROL® INSTALLATION FOR SCREENS WITHOUT A BUILT-IN LOW VOLTAGE CONTROL

Internal wiring has been completed at the factory. Installer must route power to the wall switch and to the junction box located on the left end of the screen case.

See wiring diagram below for wire connections.

NOTE: This screen can only be controlled by a single 120VAC or 240VAC wall switch. To use multiple switches, an optional low voltage control must be used.

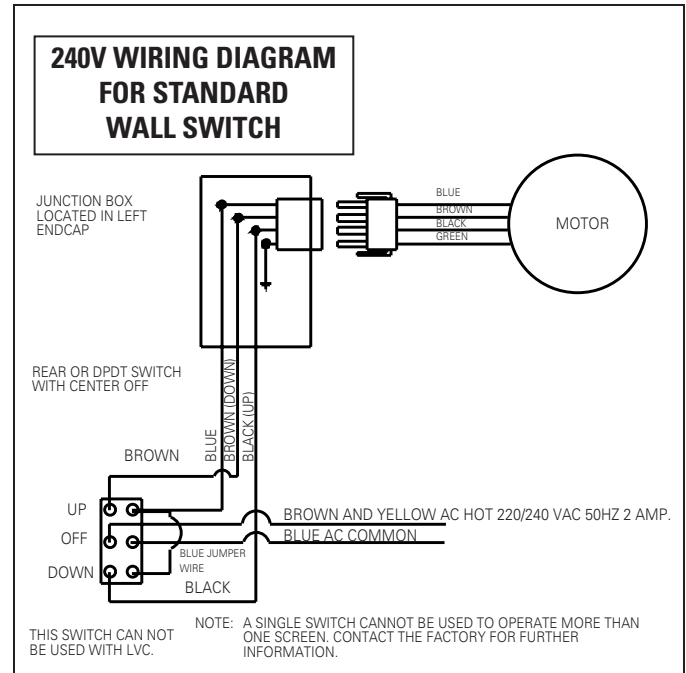
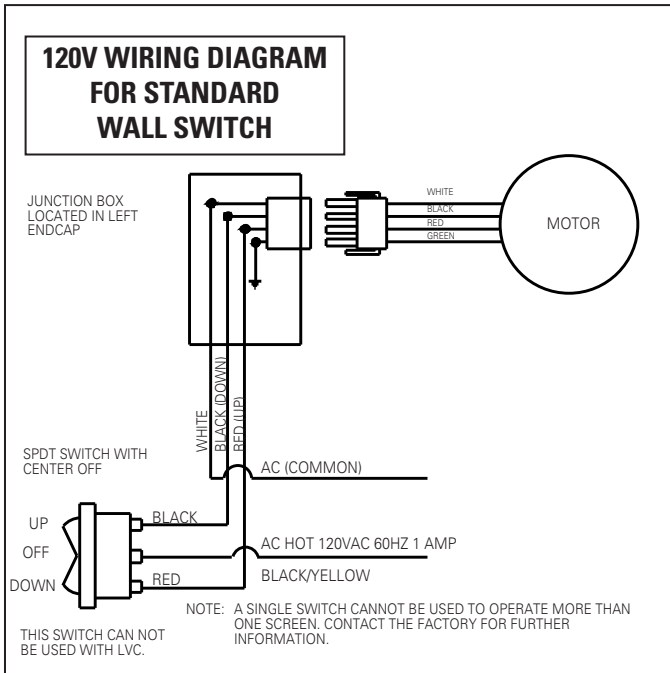

SCREEN ADJUSTMENT FOR SCREENS WITHOUT A BUILT-IN LOW VOLTAGE CONTROL

Screen travel is stopped automatically in the down and up positions by the limit switches that are preset at the factory. No further adjustment is necessary.

If you need to make minor stop position adjustments see the appropriate step below.

SETTING THE DOWN LIMIT POSITION

NOTE: One turn of the limit screw equals approximately 2" of screen travel.

TO REDUCE SCREEN DROP:

Turn the down limit switch screw clockwise to decrease the amount of screen drop. Run the screen down to test the stop position. If the screen drops too far, raise the screen about one foot and adjust the limit switch again. Repeat until the desired position is set.

TO INCREASE SCREEN DROP:

Turn the down limit switch screw counterclockwise to increase the amount of screen drop. Run the screen down to test the stop position. If the screen does not drop enough, raise the screen about one foot and adjust the limit switch again. Repeat until the desired position is set. Do not adjust for more drop than what was ordered. At least 1-1/2 wraps of fabric must remain on the roller.

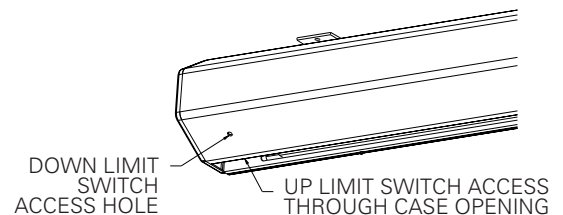

FIGURE 3

SCREEN ADJUSTMENT FOR SCREENS WITHOUT A BUILT-IN LOW VOLTAGE CONTROL

SETTING THE UP LIMIT POSITION

CAUTION: Do not allow the slat bar to wrap over the top of the roller when the screen is rolling into the case. The screen could be damaged.

SCREEN TRAVELS INTO CASE TOO FAR:

Turn the up limit switch screw clockwise to decrease the amount of travel. Run the screen up to test the stop position. If the screen does not stop properly, lower the screen about one foot and turn the limit switch again. Repeat until the desired position is set.

SCREEN DOES NOT TRAVEL FAR ENOUGH INTO CASE:

Turn the up limit switch screw counterclockwise to increase the amount of up travel. Run the screen up to test the stop position. If more travel is desired, lower the screen about one foot and adjust the limit switch again. Repeat until the desired position is set.

TENSIONED COSMOPOLITAN® ELECTROL® INSTALLATION FOR SCREENS WITH A BUILT-IN LOW VOLTAGE CONTROL

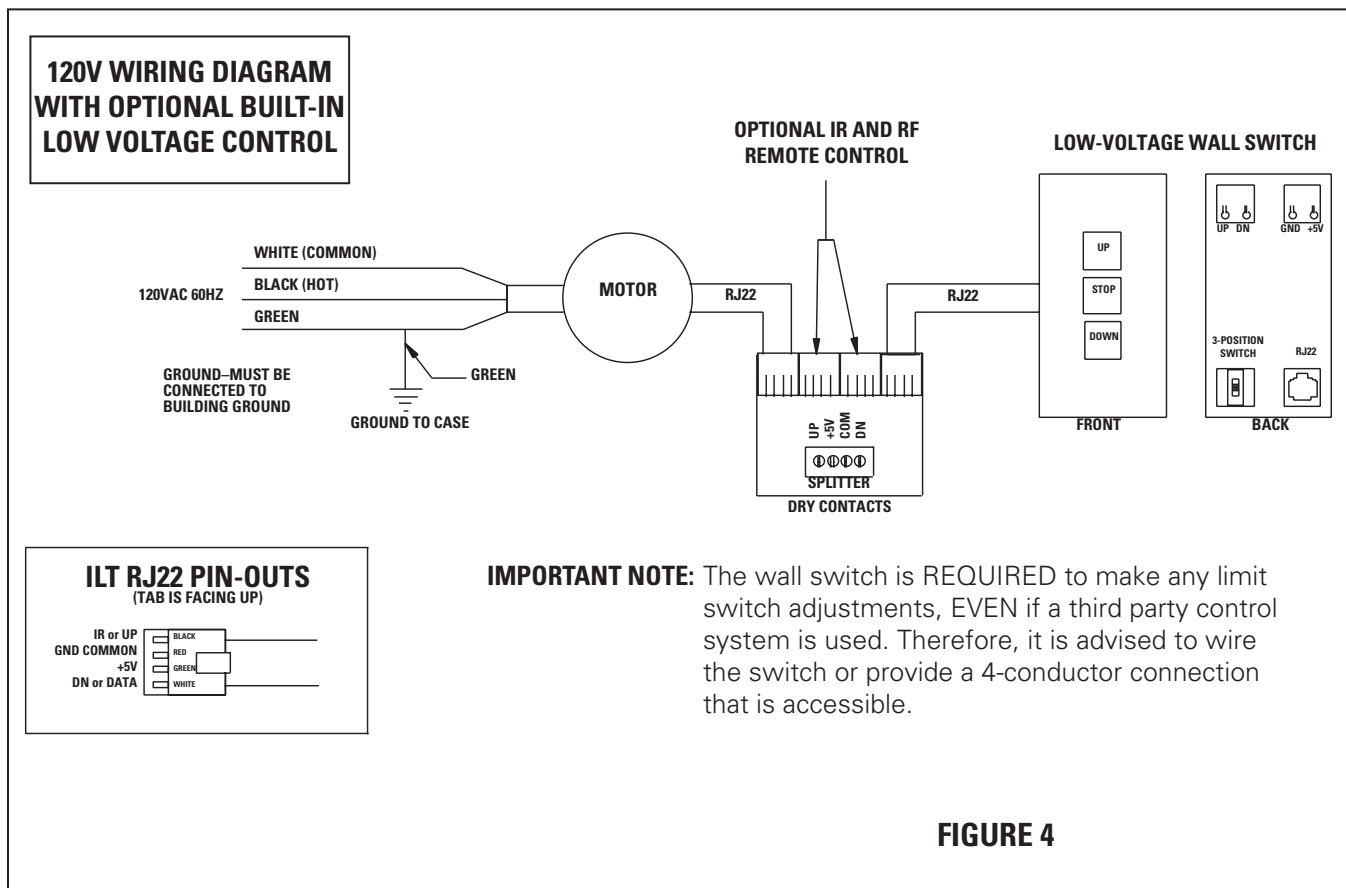

TENSIONED COSMOPOLITAN® ELECTROL® INSTALLATION FOR SCREENS WITH A BUILT-IN LOW VOLTAGE CONTROL

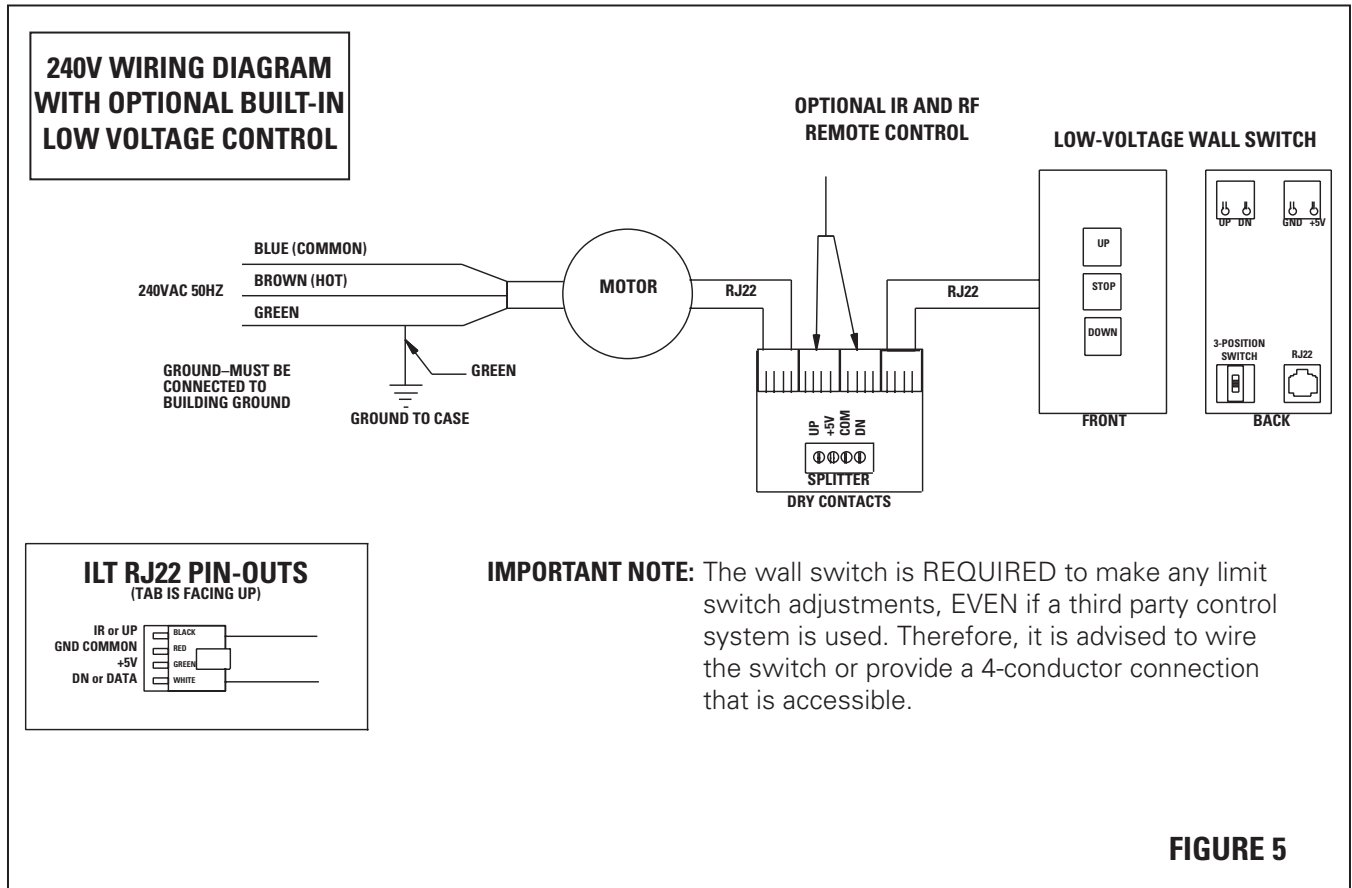

FIGURE 5

SCREEN ADJUSTMENT FOR SCREENS WITH A BUILT-IN LOW VOLTAGE CONTROL

1. Remove the cover plate from the 3-button wall switch and remove the switch from the junction box.
2. Locate small 3-position switch on back of wall switch. See Figure 4 for 120V screens or Figure 5 for 220/240V screens.
3. To adjust the down limit switch, slide the 3-position switch to the down position. Press and hold the down button to run the screen down to the desired stop position. Release the button to stop the screen. **DO NOT PUSH THE STOP BUTTON.**
4. When the screen is in the desired down position, slide the 3-position switch to the off (center) position. The down limit switch is now set.
5. To adjust the up limit switch, slide the 3-position switch to the up position. Press and hold the up button to run the screen up to the desired stop position. Release the button to stop the screen. **DO NOT PUSH THE STOP BUTTON.**
6. When the screen is in the desired up position, slide the 3-position switch to the off (center) position. The up limit switch is now set.
7. To test limit switch setting, make sure the 3-position switch is in the off (center) position. Press and release the up or down button on the wall switch to operate the screen.
8. Replace switch and cover plate on the wall.

NOTE: If stop button is pressed, the wall switch will reverse direction. To correct this, press the stop button again. This will reset the switch. You will have to re-set both the up and the down settings.

IMPORTANT NOTE: The wall switch is REQUIRED to make any limit switch adjustments, EVEN if a third party control system is used. Therefore, it is advised to wire the switch or provide a 4-conductor connection that is accessible.

TROUBLESHOOTING

| SYMPTOM | CAUSE | SOLUTION |
|---|---|--|
| 1. Screen will not operate. Motor does not hum. | (a) Blown fuse. (b) Tripped circuit breaker. (c) No power to operating switch or junction. Power at junction box (d) Thermal overload tripped. (e) Broken wire in the "down" or "up" position. (f) Defective motor, limit switch or capacitor. (g) Capacitor burned out. | (a) Replace fuse. (b) Reset circuit breaker. (c) Check above. Tighten all loose wire connections. Correct any improper connections. "Down" Position Check for power across black and white leads. "Up" Position Check for power across red and white leads. (d) Let motor cool down for 15 minutes. Try again. (e) Check for continuity. Cut off old splice and reconnect. (f) Replace motor assembly. NOTE: Motor is a sealed assembly. (g) Replace motor assembly. |
| 2. Incorrect stopping position in downward direction. | (a) Lost roller wrap. (b) "Down" limit switch out of adjustment | (a) See instructions below. (b) See installation instructions. |
| 3. Incorrect stopping position in upward direction. | (a) Lost roller wrap. (b) "Up" limit switch out of adjustment | (a) See instructions below. (b) Adjust "up" limit switch. See installation instructions |
| 4. Noise. NOTE: Screen will operate with a low pitched hum. | (a) Gear Noise. | (a) Replace motor assembly. |
| 5. Coasting. | (a) Defective brake. | (a) Replace motor assembly. |

RESTORING LOST ROLLER WRAP

1. Tape a strap to the bottom of the screen surface.
2. Push strap over back of roller.
3. Feed fabric as you pull strap to draw fabric over top of roller.
4. Remove tape and strap.