

Kramer Electronics, Ltd.

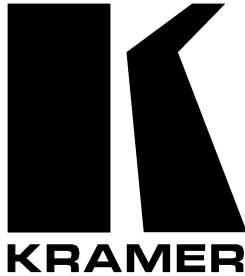

USER MANUAL

Model:

VP-727xl

Universal Presentation Matrix Switcher / Scaler

Contents

1	Introduction	1
1.1	About the VP-727xl	1
2	Getting Started	1
2.1	Quick Start	2
3	Overview	3
3.1	About HDMI	5
4	Your VP-727xl Universal Presentation Matrix Switcher / Scaler	6
5	Installing on a Rack	11
6	Connecting the VP-727xl	12
7	Connecting the VP-727xl Control Ports	17
7.1	Connecting a PC (via RS-232)	17
7.2	Connecting the AUDIO CONTROL Port	18
7.3	Connecting via RS-485	19
7.4	Connecting the VP-727xl via the ETHERNET port	20
8	Understanding the VP-727xl	21
8.1	Understanding the UNIVERSAL Inputs	21
8.2	Understanding the PREVIEW/PROGRAM Outputs	21
8.2.1	The Transition from Preview to Program	23
8.3	Switching/Scaling of an Input	23
8.4	Understanding the PIP Button Feature	23
8.4.1	Selecting the PIP Source	23
8.4.2	Activating the PIP	24
8.4.3	PIP Characteristics	24
8.5	Locking and Unlocking the Front Panel	24
8.6	Using Text Overlay	25
8.6.1	Downloading the TextOverlay Program	27
8.6.2	Setting the Text Message	27
8.6.3	Connecting and Disconnecting the TextOverlay Program	28
8.6.4	Saving and Loading Settings	29
9	Operating the VP-727xl	30
9.1	Operating via the OSD MENU Screen	30
9.1.1	Preview and Program Setting Commands	30
9.1.1.1	Preview / Program Setting Calibration Screens	32
9.1.1.2	Preview / Program Setting Output Test Pattern Screens	33
9.1.1.3	Preview / Program User Mode Output Setting	34
9.1.2	Transition Commands	35
9.1.3	Audio Settings Commands	36
9.1.4	Utility Commands	37
9.1.4.1	TCP/IP Setting Commands	38
9.1.4.2	Misc Setting Commands	38
9.1.4.2.1	Logo	38

9.1.4.2.2	Save Lock	39
9.1.4.2.3	Input Lock	39
9.1.4.3	Save/Recall/Erase Setting Commands	39
9.1.5	Information Screen	39
9.2	Operating via the Front Panel LCD Display	40
9.3	Operating via the Infra-red Remote Control Transmitter	41
9.4	Operating via ETHERNET	42
9.4.1	Installing and Running the Configuration Software	42
9.4.2	Configuring the Ethernet Connection	42
9.4.2.1	The Configuration Screen	42
9.4.3	Control the VP-727xl via the Ethernet/Serial Port	44
9.5	Operating via RS-232	45
10	Technical Specifications	46
11	VP-727xl Communication Protocol	47
12	VP-727xl Text Overlay Protocol	55

Figures

Figure 1:	VP-727xl Universal Presentation Matrix Switcher / Scaler Front Panel	7
Figure 2:	VP-727xl Universal Presentation Matrix Switcher / Scaler Rear Panel	9
Figure 3:	Connecting the VP-727xl	13
Figure 4:	Connecting the INPUTS (an example)	15
Figure 5:	Connecting the PREVIEW OUT / PROGRAM OUT Connectors	16
Figure 6:	Connecting the PC	17
Figure 7:	Connecting the VP-727A to the VP-727xl	18
Figure 8:	Connecting the VP-727T to the VP-727xl	19
Figure 9:	Example showing the use of the PREVIEW and PROGRAM Output	22
Figure 10:	TextOverlay Application Screen	25
Figure 11:	Menu Screen Icons	30
Figure 12:	Preview and Program Setting OSD Menus	30
Figure 13:	Preview Setting Calibration Menu (for HDMI and RGBHV signals)	32
Figure 14:	Program Setting Calibration Menu	32
Figure 15:	Test Pattern Screens	33
Figure 16:	User Mode Setting	34
Figure 17:	Transition OSD	35
Figure 18:	Audio Setting OSD	36
Figure 19:	Utility OSD	37
Figure 20:	TCP/IP Setting OSD	38
Figure 21:	Misc Setting OSD	38
Figure 22:	Information OSD	39
Figure 23:	Example of how to use the LCD Display	40
Figure 24:	Remote Transmitter	41
Figure 25:	VP727xl Ethernet Application Main Dialog Box (Configuration Tab)	42
Figure 26:	VP727xl Control Application Search Panel Screen	43
Figure 27:	Configuration Tab	43
Figure 28:	Setting an IP Number	44
Figure 29:	VP727xl Control Application Main Dialog Box (Control Tab)	45

Tables

Table 1: Front Panel VP-727xl Universal Presentation Matrix Switcher / Scaler Features	8
Table 2: Rear Panel VP-727xl Universal Presentation Matrix Switcher / Scaler Features	10
Table 3: Features and Functions of the TextOverlay Application	26
Table 4: Number of Buffers, Output Resolution and Maximum Display Height	27
Table 5: TextOverlay Parameters	28
Table 6: Preview and Program Setting OSD Menus	31
Table 7: Preview Setting Calibration Menu	32
Table 8: Program Setting Calibration Menu	33
Table 9: User Mode Setting Definitions	34
Table 10: Transition Effect Option Commands	35
Table 11: Audio Setting OSD Menus	36
Table 12: Utility OSD Setting	37
Table 13: TCP/IP Setting OSD	38
Table 14: Remote Transmitter Functions	41
Table 15: VP727xl Ethernet Application Configuration Tab	43
Table 16: Technical Specifications of the VP-727xl	46
Table 17: Set Commands	48
Table 18: Text Overlay Protocol of the VP-727xl	55

1 Introduction

Welcome to Kramer Electronics! Since 1981, Kramer Electronics has been providing a world of unique, creative, and affordable solutions to the vast range of problems that confront the video, audio, presentation, and broadcasting professional on a daily basis. In recent years, we have redesigned and upgraded most of our line, making the best even better! Our 500-plus different models now appear in eight groups¹ that are clearly defined by function. Congratulations on purchasing your Kramer **VP-727xl**!

1.1 About the VP-727xl

The **VP-727xl** *Universal Presentation Matrix Switcher / Scaler* is a true multi-standard video to graphics scaler and seamless switcher with 8 universal inputs comprised of 5 BNC connectors each of which can accommodate a composite video, s-Video (Y/C), component video (RGB/YUV), RGBS, or RGBHV signal. Input 1 and input 2 also accommodate HDMI inputs. It has dual scalers, one for the preview and the other for the program output. Dual scalers are required to do "live" seamless transitions from one source to another. It is ideal for these typical applications:

- Presentation applications that require a preview option
- Projection systems in conference rooms, board rooms, auditoriums, hotels, and churches
- Presentations requiring seamless switching between inputs, using special effects, cuts and fades

The package includes these items: **VP-727xl** *Universal Presentation Matrix Switcher / Scaler*, power cord², infra-red remote control transmitter (including the required battery), null-modem adapter, and this user manual³.

2 Getting Started

We recommend that you:

- Unpack the equipment carefully and save the original box and packaging materials for possible future shipment
- Review the contents of this user manual
- Use Kramer high performance high resolution cables⁴

1 GROUP 1: Distribution Amplifiers; GROUP 2: Video and Audio Switchers, Matrix Switchers and Controllers; GROUP 3: Video, Audio, VGA/XGA Processors; GROUP 4: Interfaces and Sync Processors; GROUP 5: Twisted Pair Interfaces; GROUP 6: Accessories and Rack Adapters; GROUP 7: Scan Converters and Scalers; and GROUP 8: Cables and Connectors

2 We recommend that you use only the power cord that is supplied with the machine

3 Download up-to-date Kramer user manuals from the Internet at this URL: <http://www.kramerelectronics.com>

4 The complete list of Kramer cables is on our Web site at <http://www.kramerelectronics.com>

2.1 Quick Start

This quick start chart summarizes the basic steps when connecting a **VP-727xl**:

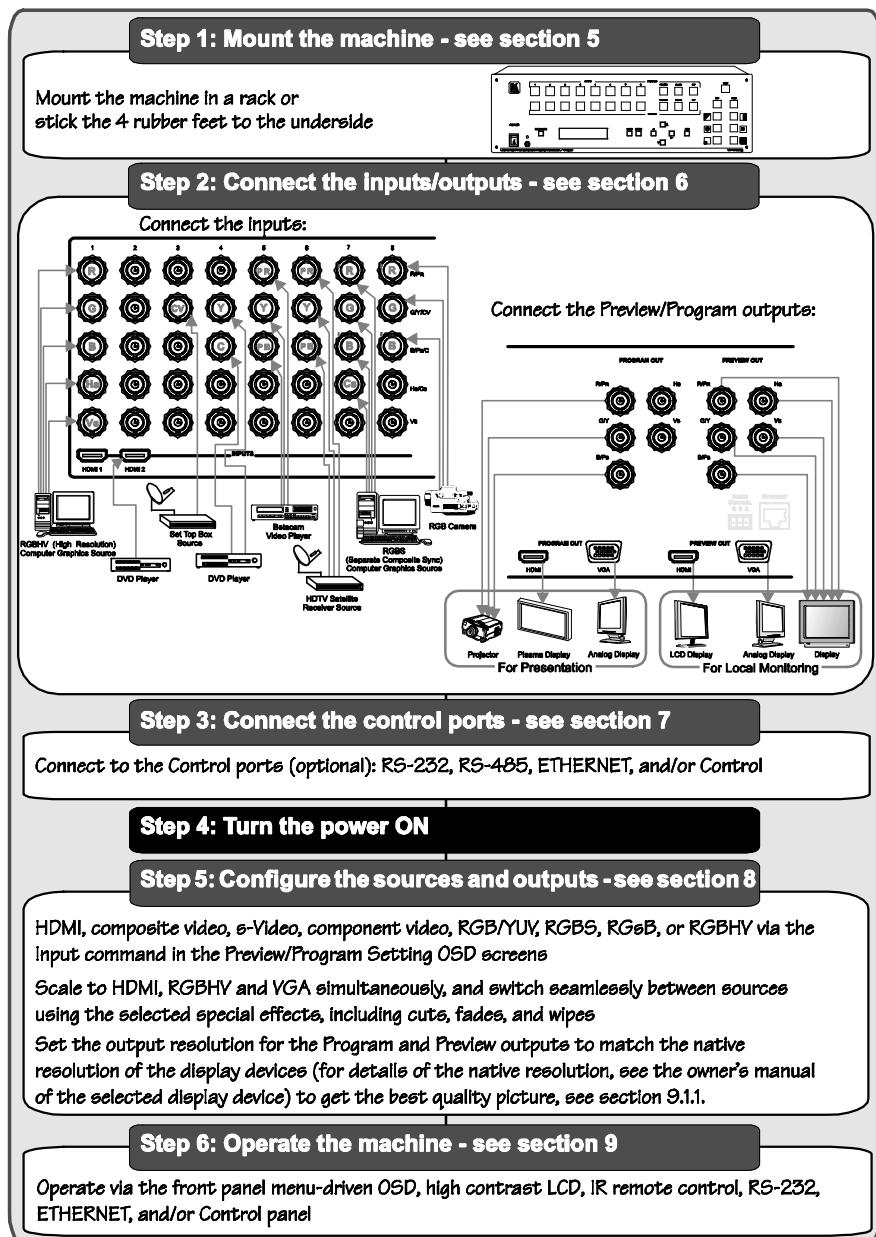

3 Overview

The **VP-727xl** *Universal Presentation Matrix Switcher / Scaler* is a true multi-standard video to graphics scaler and presentation switcher for a wide variety of presentation and multimedia applications. It consists of a very high quality scaler with many user-selectable pixel-rates including VGA (640x480), SVGA (800x600), 832x624, 852x480, XGA (1024x768), 1280x720, 1280x768, SXGA (1280x1024), 1366x768, 1365x1024, 1400x1050, UXGA (1600x1200), and high definition television HDTV: 480p, 576p, 720p, 1080i, and 1080p, as well as a user definable output mode¹.

The **VP-727A** *Audio Switcher* is an audio companion switcher for the **VP-727xl**, and operates in conjunction with it and the **VP-727T** *Presentation Switcher Control Panel*.

In particular, the **VP-727xl**:

- Features 8 sets of universal INPUT BNC connectors: R/PR, G/Y/CV, B/PB/C, HS/CS, and Vs. Each set can be programmed to operate as: composite video, s-Video, component video², RGsB/YUV, RGBS, or RGBHV
- Includes two HDMI inputs (for input 1 and input 2) that support up to 1.65Gbps bandwidth per graphic channel³
- Supports HDCP (High Definition Digital Content Protection)
- Scales the selected sources to HDMI, RGBHV (Y, Pb, Pr) and VGA outputs simultaneously
- Has dual scalers—for “live” seamless transitions from one source to another—with two independent outputs: a PREVIEW OUT and a PROGRAM OUT (see section 8.2). The PREVIEW output—including an OSD menu for making adjustments—is for determining how the scaled output will look before displaying live during a presentation, as well as for setting the special effects that harmonize the transition when changing between sources. Both outputs have separate sets of connectors for HDMI, VGA (a 15-pin HD computer graphics video connector), and RGBHV / YPbPr (on BNC connectors)
- Features 8 PREVIEW input buttons for switching a selected input to the PREVIEW output and 8 PROGRAM input buttons for switching a selected input to the PROGRAM output
- Includes two transition modes (accessible via the OSD): the Swap mode and the Follow mode. When pressing the TAKE button in the Swap mode,

¹ Recommended for advanced users only – non-standard settings may not be recognized by the display device

² Sometimes called YUV, or Y, B-Y, R-Y, or Y, Pb, Pr. The component input type (HDTV or YCbCr) may be set as HD or SD

³ Suitable for resolutions up to UXGA at 60Hz, and for all HD resolutions

the preview and program inputs switch positions; when pressing in the Follow mode, the program input follows the preview input

- Scales and zooms (to up to 400% of the original size)
- Offers high quality de-interlacing 3:2/2:2 pull down¹
- Has a text overlay feature for easy insertion of subtitles, karaoke script, and text banners
- Has built-in Picture-In-Picture inserters for both the PREVIEW and the PROGRAM outputs, letting you insert a video source into a graphics background or vice versa. This PIP image may be positioned and sized anywhere on the screen, or displayed as two images side by side (Split Screen)
- Saves all settings in non-volatile memory in the unit
- Supports firmware upgrade via RS 232
- Features a sophisticated front panel lockout²
- Features a Take button for executing preview to program switching (with transition effects, which include cuts, fades, and wipes³)
- Has ProcAmp⁴ controls for both outputs
- Has multi-standard video support: PAL, SECAM, and NTSC (3.58/4.43)
- Has a built-in Time Base Corrector that stabilizes video sources with unstable sync
- Features multiple color space, outputting RGB or YUV (selectable)
- Digitally reprocesses the signal to correct mastering errors, and regenerates the video at a chosen line and pixel rate format, providing, for example, native-resolution video for LCD, DLP and Plasma displays
- Facilitates scaling of graphics resolutions to other resolutions
- Incorporates a unique graphics-scaling engine with image enhancement algorithms, which are built into the firmware
- Is specifically designed to improve video quality by reducing chroma noise
- Comes in a rugged, professional 19" 3U rack-mountable metal enclosure
- Uses a universal 100-240VAC automatic power supply

¹ Accommodates the frame-rate of a converted movie (24 frames per second) to video frequencies (25 frames per second (PAL); 30 frames per second (NTSC))

² See sections 8.5 and 9.1.4.2

³ The wipe can be from left to right, right to left, up or down, and the corner wipe can start from any corner. The speed of each transition can be adjusted

⁴ Processing amplification enables adjustment of different video and audio signal parameters

Control the **VP-727xl** via the:

- Front panel user-friendly menu-driven OSD (see section 9.1)
- High contrast LCD Display (see section 9.2)
- IR remote control transmitter (see section 9.3)
- ETHERNET (see section 9.4)
- RS-232 (see section 9.5)
- Kramer **VP-727T Presentation Switcher Control Panel**¹

3.1 About HDMI

High-Definition Multimedia Interface (HDMI) is an uncompressed all-digital² audio/video interface, widely supported in the entertainment and home cinema industry. It delivers the highest high-definition image and sound quality. Note that Kramer Electronics Limited is an HDMI Adopter³ and an HDCP Licensee⁴.

In particular, HDMI⁵:

- Provides a simple⁶ interface between any audio/video source, such as a set-top box, DVD player, or A/V receiver and video monitor, such as a digital flat LCD / plasma television (DTV), over a single lengthy⁷ cable
- Supports standard, enhanced, high-definition video, and multi-channel digital audio⁸ on a single cable
- Transmits all ATSC HDTV standards and supports 8-channel digital audio, with bandwidth to spare to accommodate future enhancements and requirements
- Benefits consumers by providing superior, uncompressed digital video quality via a single cable⁹, and user-friendly connector
- Is backward-compatible with DVI (Digital Visual Interface)

1 See the separate user manual on our Web site at <http://www.kramerelectronics.com>

2 Ensuring an all-digital rendering of video without the losses associated with analog interfaces and their unnecessary digital-to-analog conversions

3 See http://www.hdmi.org/about/adopters_founders.asp

4 See <http://www.digital-cp.com/list/>

5 HDMI, the HDMI logo and High-Definition Multimedia Interface are trademarks or registered trademarks of HDMI licensing LLC

6 With video and multi-channel audio combined into a single cable, the cost, complexity, and confusion of multiple cables currently used in A/V systems is reduced

7 HDMI technology has been designed to use standard copper cable construction at up to 15m

8 HDMI supports multiple audio formats, from standard stereo to multi-channel surround-sound. HDMI has the capacity to support Dolby 5.1 audio and high-resolution audio formats

9 HDMI provides the quality and functionality of a digital interface while also supporting uncompressed video formats in a simple, cost-effective manner

- Supports two-way communication between the video source (such as a DVD player) and the digital television, enabling new functionality such as automatic configuration and one-button play

HDMI has the capacity to support existing high-definition video formats (720p, 1080i, and 1080p/60), standard definition formats such as NTSC or PAL, as well as 480p and 576p.

Achieving the best performance means:

- Connecting only good quality connection cables, thus avoiding interference, deterioration in signal quality due to poor matching, and elevated noise levels (often associated with low quality cables)
- Avoiding interference from neighboring electrical appliances, making sure not to block the ventilation holes, and positioning your **VP-727xl** away from moisture, excessive sunlight and dust

4 Your VP-727xl Universal Presentation Matrix Switcher / Scaler

Figure 1 and Table 1 define the front panel of the **VP-727xl**:

Your VP-727xl Universal Presentation Matrix Switcher / Scaler

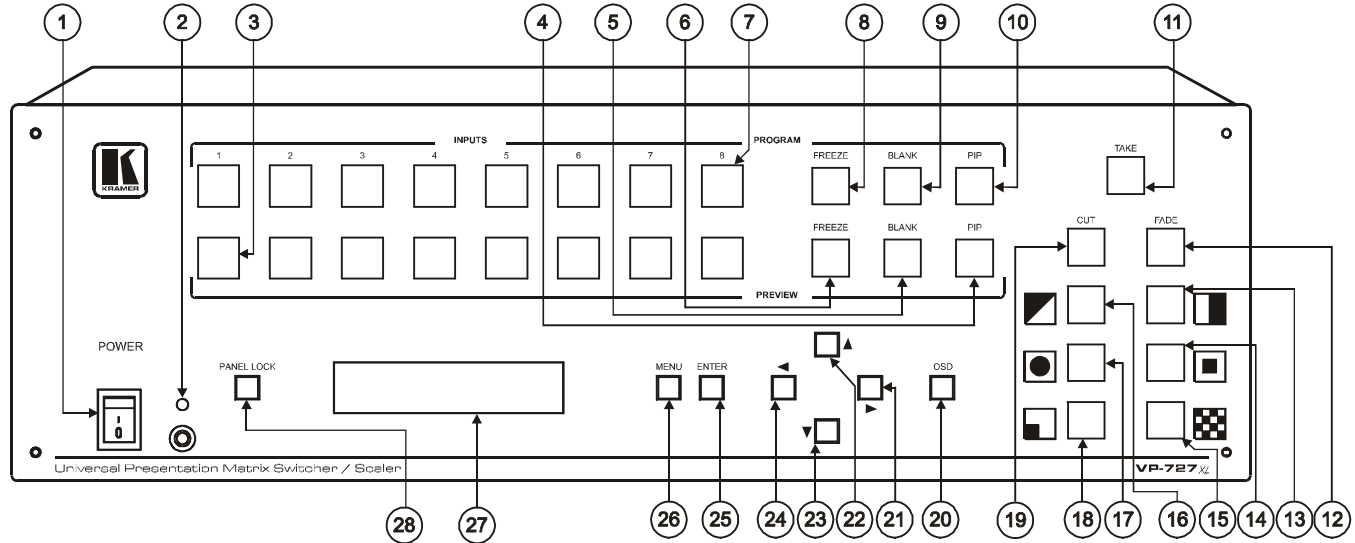

Figure 1: VP-727xl Universal Presentation Matrix Switcher / Scaler Front Panel

Table 1: Front Panel VP-727xl Universal Presentation Matrix Switcher / Scaler Features











#	Feature	Function	
1	POWER Switch	Illuminated switch for turning the unit ON or OFF	
2	IR Receiver / LED	Green when the unit will accept IR remote commands; red in standby mode ¹	
3	PREVIEW Buttons	INPUTS	Selects one of the R/Pr, G/Y/CV, B/Pb/C, Hs/Cs, Vs sources (from 1 to 8) ²
4		PIP	Toggles the picture-in-picture function on and off
5		BLANK	Toggles between a blank screen and the selected input
6		FREEZE	Freezes the output video image (toggle)
7	PROGRAM Buttons	INPUTS	Selects one of the sources: R/Pr, G/Y/CV, B/Pb/C, Hs/Cs, Vs (from 1 to 8)
8		FREEZE	Freezes the output video image (toggle)
9		BLANK	Toggles between a blank screen and the selected input
10		PIP	Toggles the picture-in-picture function on and off
11	TAKE Button ³	Pressing TAKE causes the transition to occur	
12	FADE ⁸ Button	Selects a dissolved transition from the PREVIEW output to the PROGRAM output	
13	TRANSITION Buttons ^{3,4}		Selects a WIPE transition effect ⁵
14			Selects a SQUARE transition effect ⁷
15			Selects a CHESSBOARD transition effect ⁷
16			Selects a DIAGONAL transition effect ⁶
17			Selects a CIRCLE transition effect ⁷
18			Selects a CORNER transition effect ⁶
19	CUT ⁸ Button	Selects an instantaneous transition from the PREVIEW output to the PROGRAM output	
20	OSD Button	Activates/deactivates access to the OSD Menu	
21	DIRECTION Buttons		Toggles within each level 2 command / increases the range by one step
22			Moves up one step (in the same level) in the OSD menu
23			Moves down one step (in the same level) in the OSD menu
24			Toggles within each level 2 command / decreases the range by one step
25	ENTER Button	Moves to the next level in the OSD menu	
26	MENU Button	Displays the OSD Menu screen (or moves to the previous level in the OSD menu)	
27	LCD STATUS Display	Displays the status of the unit, and is used for menu navigation	
28	PANEL LOCK Button	Locks/unlocks the front panel	

Figure 2 and Table 2 define the rear panel of the **VP-727xl**:

1 After pressing the POWER key on the remote control transmitter (see Figure 24). The machine is in standby mode (power consumption is reduced) and the power switch (item 1) on the machine continues to illuminate

2 The INPUT buttons 1 and 2 also select the HDMI sources 1 and 2, respectively

3 The effect is only seen in PROGRAM Mode. The PREVIEW screen will blank during the transition

4 Select a specific effect for the transition from the PREVIEW output to the PROGRAM output

5 Choose the direction from where the effect starts: “left to right”, “right to left”, “up” or “down” (see section 9.1.2)

6 Choose the direction from where the effect starts: “top left”, “bottom left”, “top right” or “bottom right” (see section 9.1.2)

7 Choose the direction from where the effect starts: “in” or “out” (see section 9.1.2)

8 Only for setting up the unit for the effect. The effect will only occur when the Take button is pressed

Your VP-727xl Universal Presentation Matrix Switcher / Scaler

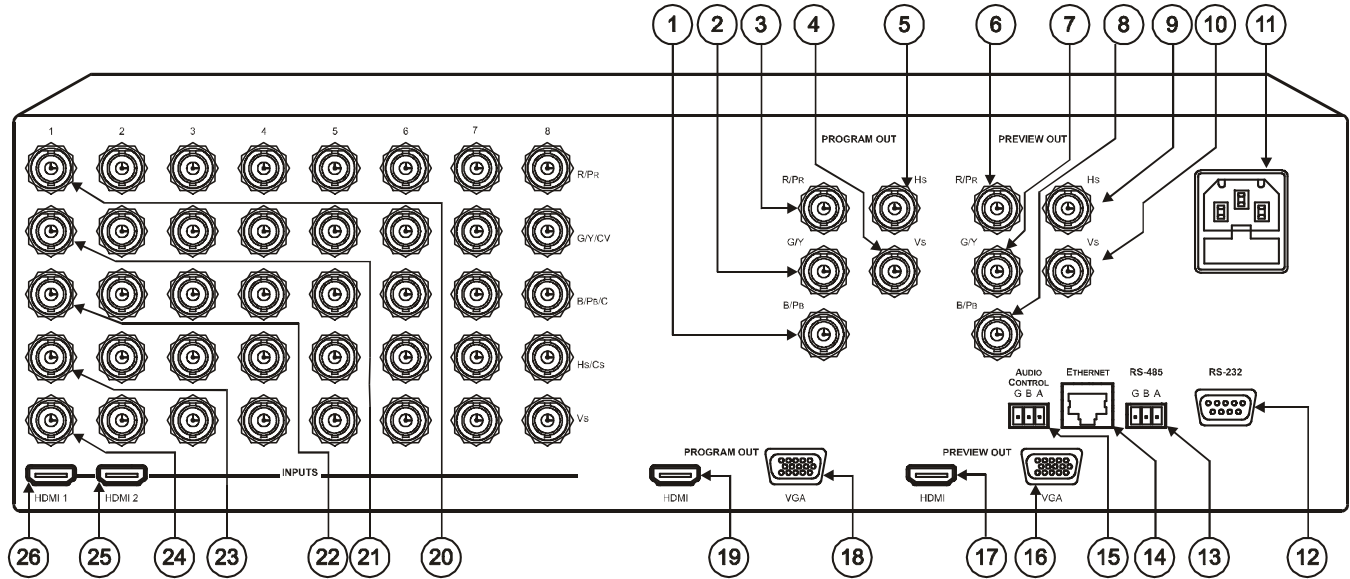

Figure 2: VP-727xl Universal Presentation Matrix Switcher / Scaler Rear Panel

Table 2: Rear Panel VP-727xl Universal Presentation Matrix Switcher / Scaler Features

#	Feature	Function
1	PROGRAM OUT	B/Pb BNC Connector
2		G/Y BNC Connector
3		R/Pr BNC Connector
4		Vs BNC Connector
5		Hs BNC Connector
6	PREVIEW OUT	R/Pr BNC Connector
7		G/Y BNC Connector
8		B/Pb BNC Connector
9		Hs BNC Connector
10		Vs BNC Connector
11	Power Connector with <i>FUSE</i>	AC connector enabling power supply to the unit
12	RS-232 DB 9 Connector	Connects to PC or Serial Controller
13	RS-485 Port	Connects to the Kramer VP-727T Presentation Switcher Control Panel (optional). Pin G is for the Ground connection ² ; pins B (-) and A (+) are for RS-485
14	ETHERNET Port	Connects to your LAN ³
15	AUDIO CONTROL Port	Connects to the Kramer VP-727A Audio Switcher (optional). Pin G is for the Ground connection ² ; pins B (-) and A (+) are for RS-485
16	PREVIEW OUT	VGA HD15 Connector
17		HDMI Connector
18	PROGRAM OUT	VGA HD15 Connector
19		HDMI Connector
20	INPUTS (from 1 to 8)	R/Pr BNC Connector
21		G/Y/CV BNC Connector
22		B/Pb/C BNC Connector
23		Hs/Cs BNC Connector
24		Vs BNC Connector
25	INPUTS	HDMI 2 Connector
26		HDMI 1 Connector

1 Sometimes called YUV; Y, B-Y, R-Y; Y, Pb, Pr; or Y, Cb, Cr

2 The ground connection is sometimes connected to the shield of the RS-485 cable. In most applications, the ground is not connected

3 Local Area Network (that is, computers sharing a common communications line or wireless link, which often share a server within a defined geographic area)

4 Made up of the Y on the G/Y/CV connector together with the C on the B/Pb/C connector

5 Installing on a Rack

This section describes what to do before installing on a rack and how to rack mount.

Before Installing on a Rack

Before installing on a rack, be sure that the environment is within the recommended range:	
Operating temperature range	+5 to +45 Deg. Centigrade
Operating humidity range	10 to 90% RHL, non-condensing
Storage temperature range	-20 to +70 Deg. Centigrade
Storage humidity range	5 to 95% RHL, non-condensing



CAUTION!!

When installing on a 19" rack, avoid hazards by taking care that:

- 1 It is located within the recommended environmental conditions, as the operating ambient temperature of a closed or multi unit rack assembly may exceed the room ambient temperature.
- 2 Once rack mounted, enough air will still flow around the machine.
- 3 The machine is placed straight in the correct horizontal position.
- 4 You do not overload the circuit(s). When connecting the machine to the supply circuit, overloading the circuits might have a detrimental effect on overcurrent protection and supply wiring. Refer to the appropriate nameplate ratings for information. For example, for fuse replacement, see the value printed on the product label.
- 5 The machine is earthed (grounded) in a reliable way and is connected only to an electricity socket with grounding. Pay particular attention to situations where electricity is supplied indirectly (when the power cord is not plugged directly into the socket in the wall), for example, when using an extension cable or a power strip, and that you use only the power cord that is supplied with the machine.

How to Rack Mount

To rack-mount a machine:

- 1 Attach both ear brackets to the machine. To do so, remove the screws from each side of the machine (3 on each side), and replace those screws through the ear brackets.

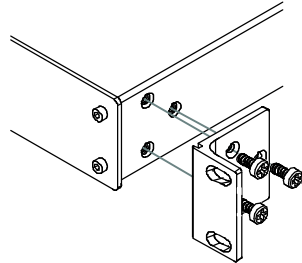

- 2 Place the ears of the machine against the rack rails, and insert the proper screws (not provided) through each of the four holes in the rack ears.

Note that:

- In some models, the front panel may feature built-in rack ears
- Detachable rack ears can be removed for desktop use
- Always mount the machine in the rack before you attach any cables or connect the machine to the power
- If you are using a Kramer rack adapter kit (for a machine that is not 19"), see the Rack Adapters user manual for installation instructions (you can download it at: <http://www.kramerelectronics.com>)

6 Connecting the VP-727xl

The **VP-727xl** is a universal presentation matrix switcher / scaler that lets you choose what sources to connect to the inputs. For example, you can connect just four sources: an RGBHV source, an HDMI source, an HDTV source and an RGBS source (as the example in Figure 3 shows).

To connect¹ the **VP-727xl** as illustrated in the example in Figure 3, do the following:

1. Connect the following video sources:
 - An RGBHV (high resolution) computer graphics source to the R/PR, G/Y/CV, B/PB/C, HS/CS and VS BNC INPUT 1 connectors
 - An HDMI source to the INPUT HDMI 2 connector
 - An HDTV satellite receiver source to the R/PR, G/Y/CV, and B/PB/C BNC INPUT 6 connectors
 - An RGBS (separate composite sync) computer graphics source to the R/PR, G/Y/CV, B/PB/C, and HS/CS BNC INPUT 8 connectors
2. Connect the PROGRAM OUT:
 - HDMI connector to the plasma display
 - VGA HD15F connector to the analog display
 - R/PR, G/Y, B/PB, (PR, Y, PB) BNC OUTPUT connectors to the YUV acceptor, for example, a projector
3. Connect the PREVIEW OUT R/PR, G/Y, B/PB, HS and VS BNC OUTPUT connectors to the display
4. Connect the power cord².
5. If required, connect:
 - A PC via RS-232, see section 7.1
 - The Kramer **VP-727A** *Audio Switcher* via the AUDIO CONTROL port, see section 7.2
 - The Kramer **VP-727T** *Presentation Switcher Control Panel* via the RS-485 port, see section 7.3
 - The ETHERNET port, see section 7.4

¹ Switch OFF the power on each device before connecting it to your VP-727xl. After connecting your VP-727xl, switch on its power and then switch on the power on each device

² We recommend that you use only the power cord that is supplied with this machine

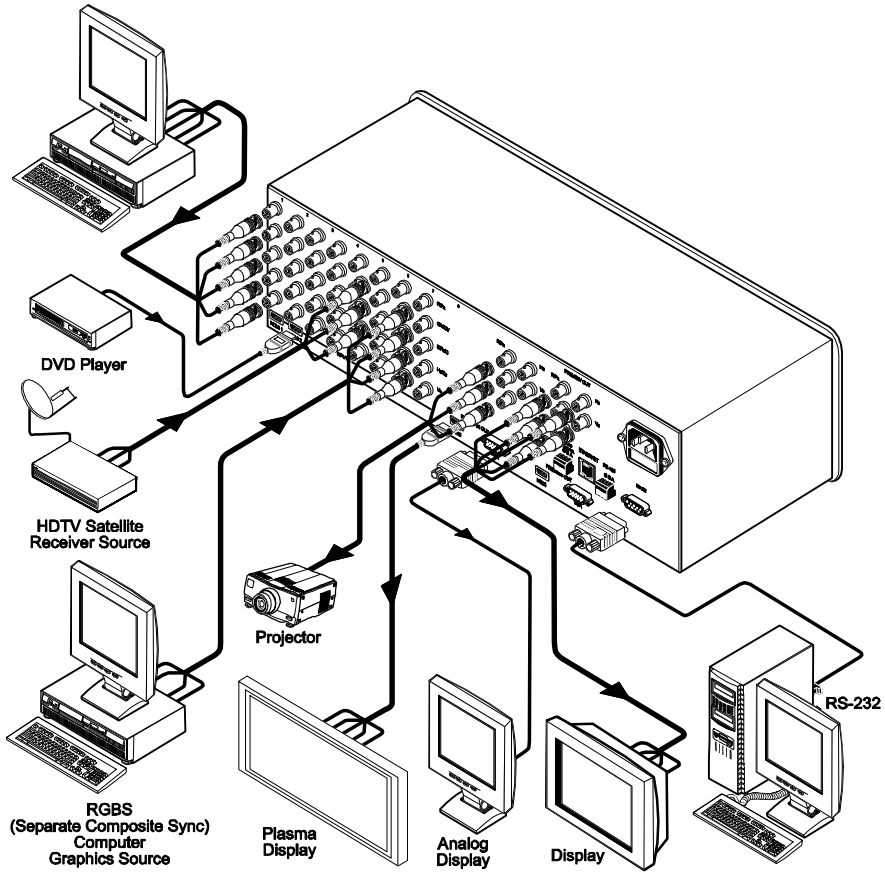

Figure 3: Connecting the VP-727xl

Figure 4 shows an example of how to connect¹ 8 sources to the rear panel of the **VP-727xl**: an RGBHV source, an HDMI source, a CV source, a Y/C source, a component video source, an HDTV source, an RGBCs source and an RGB source.

To connect² the **VP-727xl**, as illustrated in the example in Figure 4, do the following³:

1. Connect the following video sources² (see Figure 4):
 - An RGBHV (high resolution) computer graphics source to the R/PR, G/Y/CV, B/PB/C, HS/CS and VS BNC INPUT 1 connectors
 - An HDMI source to the INPUT HDMI 2 connector
 - A set top box to the G/Y/CV BNC INPUT 3 connector
 - A DVD player to the G/Y/CV and B/PB/C BNC INPUT 4 connectors
 - A component source—for example, a Betacam video player—to the R/PR, G/Y/CV, and B/PB/C BNC INPUT 5 connectors
 - An HDTV satellite receiver source to the R/PR, G/Y/CV, and B/PB/C BNC INPUT 6 connectors
 - An RGBCs (separate composite sync) computer graphics source to the R/PR, G/Y/CV, B/PB/C, and HS/CS BNC INPUT 7 connectors
 - An RGB camera to the R/PR, G/Y/CV, and B/PB/C BNC INPUT 8 connectors

¹ Figure 4 and Figure 5 show how to connect several sources, and the PREVIEW/PROGRAM OUT connectors, respectively

² As this particular example describes. As the VP-727xl is universal, you can connect any type (format) of video to the inputs

³ Switch OFF the power on each device before connecting it to your VP-727xl. After connecting your VP-727xl, switch on its power and then switch on the power on each device

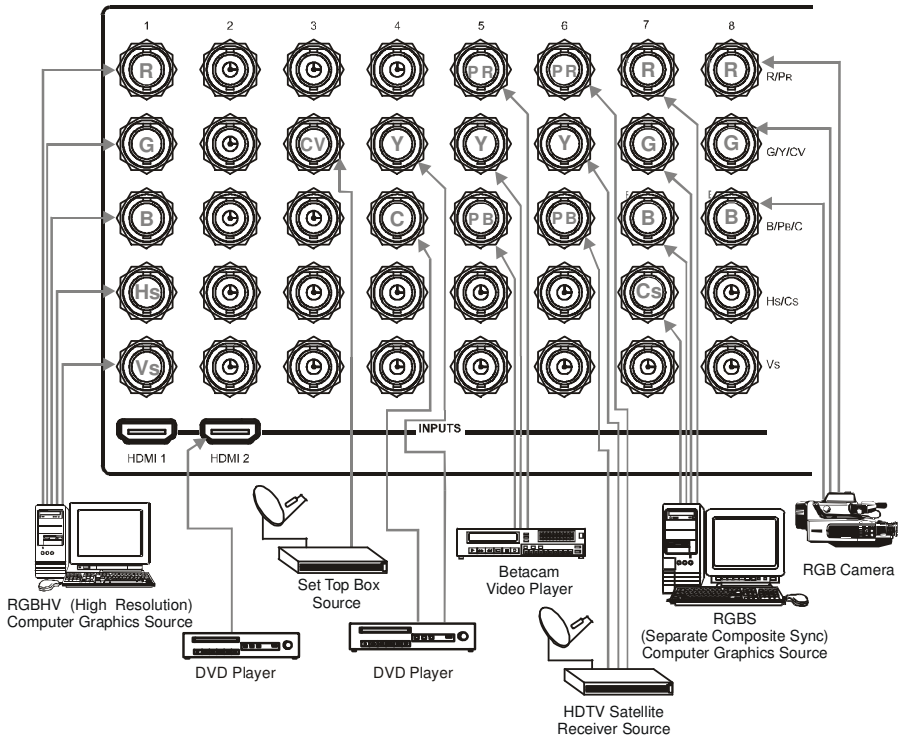

Figure 4: Connecting the INPUTS (an example)

2. Connect the PROGRAM OUT (see Figure 5):
 - R/PR, G/Y, B/PB, (PR, Y, PB) BNC OUTPUT connectors to the YUV acceptor, for example, a projector
 - HDMI connector to a plasma display
 - VGA a 15-pin HD computer graphics video connector to an analog display

3. Connect the PREVIEW OUT (see Figure 5):
 - HDMI connector to an LCD display
 - VGA 15-pin HD computer graphics video connector to an analog display
 - R/PR, G/Y, B/PB, HS and VS BNC OUTPUT connectors to a display

Connecting the VP-727x1

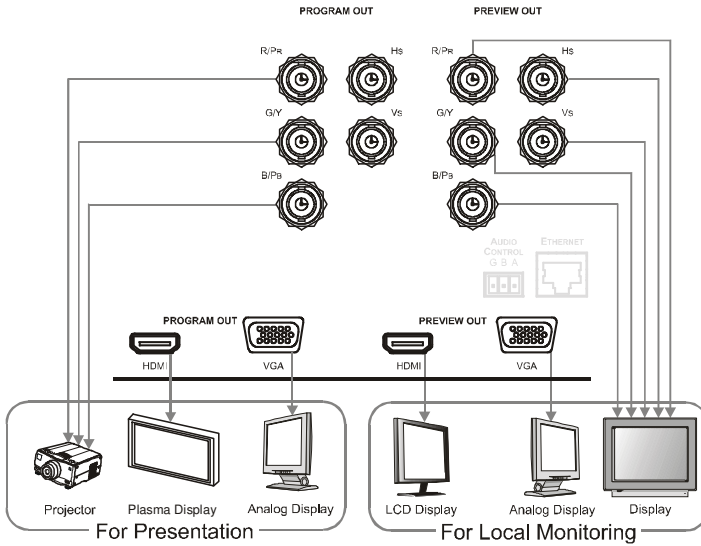

Figure 5: Connecting the PREVIEW OUT / PROGRAM OUT Connectors

4. Connect the power cord¹.
5. If required, connect:
 - A PC via RS-232, see section 7.1
 - The Kramer **VP-727A** Audio Switcher via the AUDIO CONTROL port, see section 7.2
 - The Kramer **VP-727T** Presentation Switcher Control Panel via the RS-485 port, see section 7.3
 - The ETHERNET port, see section 7.4

¹ We recommend that you use only the power cord that is supplied with this machine

7 Connecting the VP-727xl Control Ports

This section describes how to connect the **VP-727xl** control ports, that is, the:

- RS-232 port, see section 7.1
- AUDIO CONTROL port, see section 7.2
- RS-485 port, see section 7.3
- ETHERNET port, see section 7.4

7.1 Connecting a PC (via RS-232)

You can connect a PC (or other controller) to the **VP-727xl** via the RS-232 port for remote control, and for upgrading the firmware.

To connect a PC to a **VP-727xl** unit, using the Null-modem adapter provided with the machine (recommended):

- Connect the RS-232 DB9 rear panel port on the **VP-727xl** unit to the Null-modem adapter and connect the Null-modem adapter with a 9 wire flat cable to the RS-232 DB9 port on your PC

To connect a PC to a **VP-727xl** unit, without using a Null-modem adapter:

- Connect the RS-232 DB9 port on your PC to the RS-232 DB9 rear panel port on the **VP-727xl** unit, forming a cross-connection¹, as Figure 6 illustrates

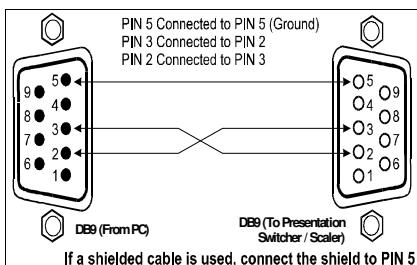

Figure 6: Connecting the PC

¹ Also known as a Null-modem connection

7.2 Connecting the AUDIO CONTROL Port

The Kramer **VP-727A Audio Switcher** operates in conjunction with the **VP-727xl**. When connected, the audio switcher signals follow the video signals¹.

To connect the **VP-727xl** to the Kramer **VP-727A Audio Switcher** via the AUDIO CONTROL RS-485 port, as illustrated in the example in Figure 7, do the following:

- Connect the “A” (+) PIN on the AUDIO CONTROL RS-485 rear panel port of the **VP-727xl** to the A (+) PIN on the RS-485 rear panel port of the **VP-727A** unit
- Connect the “B” (-) PIN on the AUDIO CONTROL RS-485 rear panel port of the **VP-727xl** to the B (-) PIN on the RS-485 rear panel port of the **VP-727A** unit
- If shielded twisted pair cable is used, the shield may be connected to the “G” (Ground) PIN on one of the units

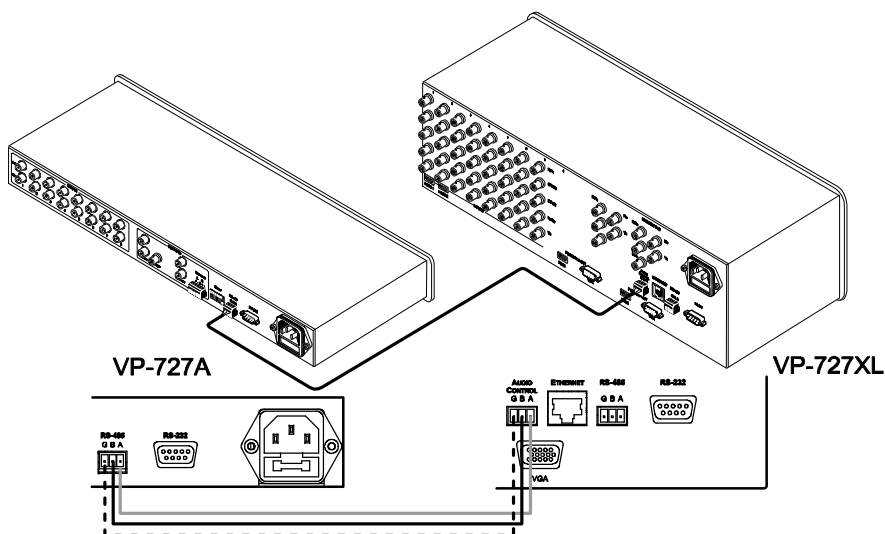

Figure 7: Connecting the VP-727A to the VP-727xl

¹ See the separate VP-727A user manual on our Web site at <http://www.kramerelectronics.com>

7.3 Connecting via RS-485

To connect the **VP-727xl** to the Kramer **VP-727T Presentation Switcher Control Panel**¹ via the RS-485 control port, as illustrated in Figure 8, do the following:

- Connect the “A” (+) PIN on the RS-485 rear panel port of the **VP-727xl** to the A (+) PIN on the RS-485 rear panel port of the **VP-727T** unit
- Connect the “B” (-) PIN on the RS-485 rear panel port of the **VP-727xl** to the B (-) PIN on the RS-485 rear panel port of the **VP-727T** unit
- If shielded twisted pair cable is used, the shield may be connected to the “G” (Ground) PIN on one of the units

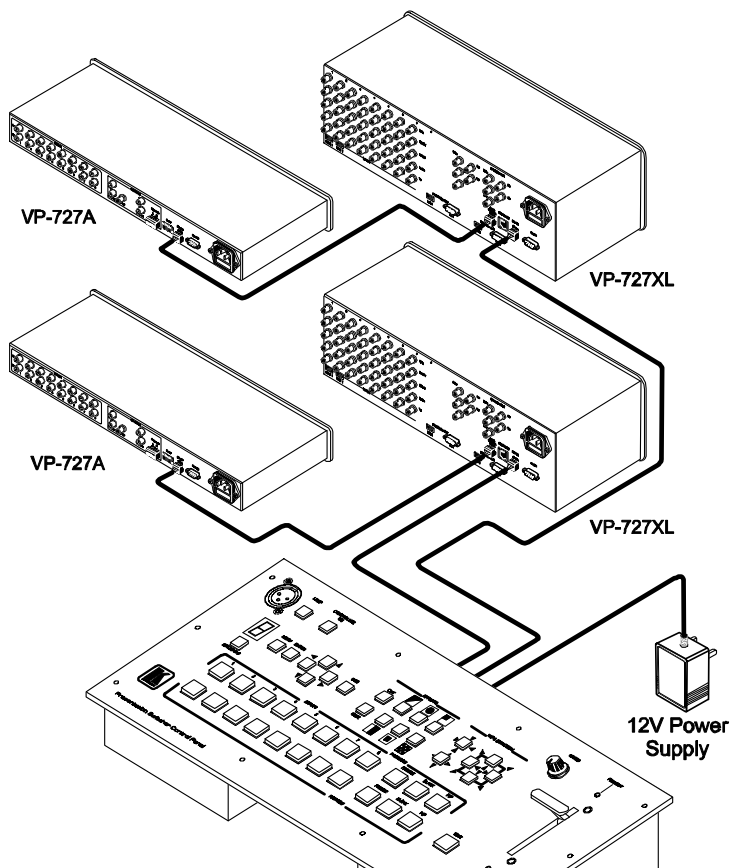

Figure 8: Connecting the VP-727T to the VP-727xl

¹ See the separate VP-727T user manual on our Web site at <http://www.kramerelectronics.com>

7.4 Connecting the VP-727xl via the ETHERNET port

To connect the **VP-727xl** via the ETHERNET port, do the following:

Connect the ETHERNET port of the **VP-727xl** to the LAN port of your PC, via a crossover cable with RJ-45 connectors.

If connecting the ETHERNET port of the **VP-727xl** to the LAN port on a network hub or network router, use a straight-through cable with RJ-45 connectors.

8 Understanding the VP-727xl

This section describes the:

- UNIVERSAL inputs, see section 8.1
- PREVIEW/PROGRAM outputs, see section 8.2
- Switching/Scaling of an input, see section 8.3
- PIP feature, see section 8.4
- Panel Lock, see section 8.5

8.1 Understanding the UNIVERSAL Inputs

The **VP-727xl** has 8 sets of inputs¹; each set can be programmed to operate as composite video, s-Video, component video, RGB/YUV, RGBS, RGsB, or RGBHV. INPUT 1 and INPUT 2 can also accept HDMI inputs.

The **VP-727xl** is a **universal** presentation matrix switcher / scaler: you choose what type of source to connect to each input. You can connect different video types or the same or similar video types. See the examples in Figure 3 and Figure 4 in section 6.

8.2 Understanding the PREVIEW/PROGRAM Outputs

The **VP-727xl** has two outputs: a PREVIEW output, and a PROGRAM output. Each of these outputs functions independently and has HDMI connectors and VGA connectors, as well as sets of 5 BNC connectors²: R/PR, G/Y, B/PB, Hs, and Vs.

The HDMI signal is usually HDCP protected. It is therefore recommended to use a display that is HDCP compliant, otherwise the HDMI output will not appear on the screen

Using the **PREVIEW** output, you can:

- See how the scaled output will look before displaying live during a presentation. As the example in Figure 9 illustrates, after seeing how the RGB source looks when scaled to HDMI, it can be interchanged with the YUV source, seamlessly, using an elaborate (in this case chessboard) transition effect
- Harmonize transition to the PROGRAM output after determining the look and feel when in the PREVIEW output
- Use the OSD menu to make adjustments and choose the settings
- Set the transition, choosing one of any eight special effects

¹ Each set consists of 5 BNC connectors: R/Pr, G/Y/CV, B/Pb/C, Hs/Cs, and Vs

² Used to output one of the following: RGB, RGBHV, or component video

Using the **PROGRAM** output, after pressing the TAKE button, you can see the transition¹.

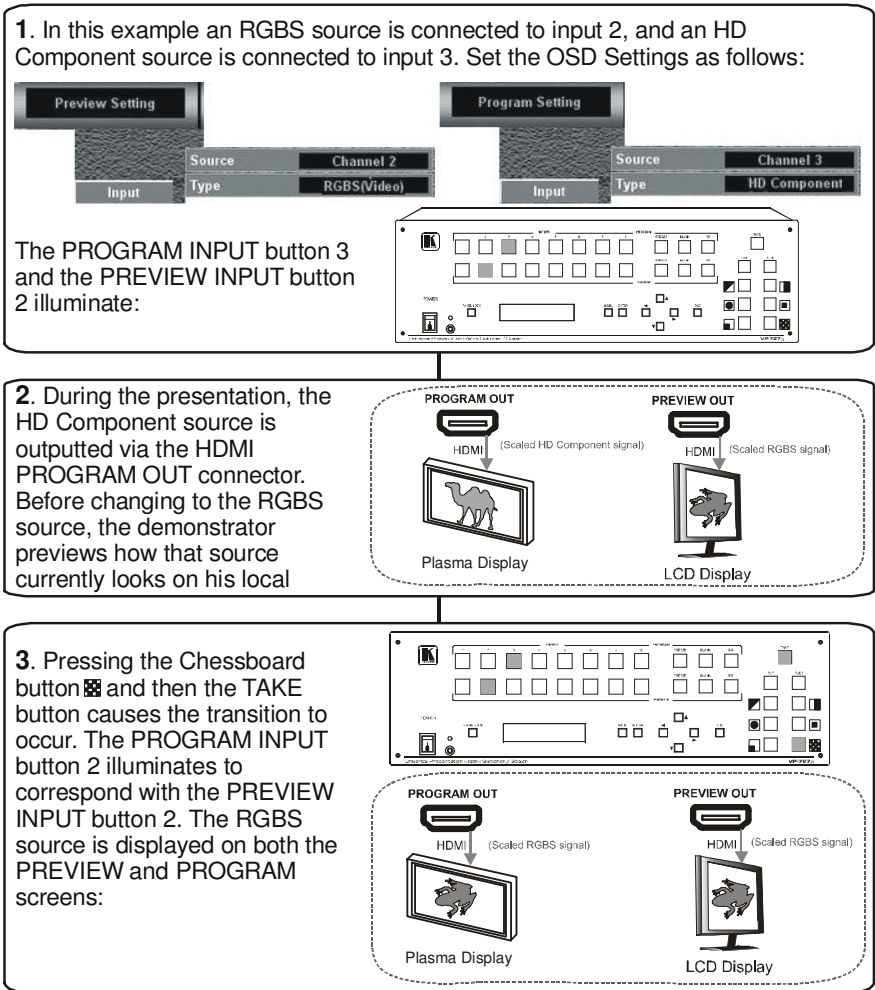

Figure 9: Example showing the use of the PREVIEW and PROGRAM Output

¹ After making some changes in the unit (for example, selecting a new input to the PREVIEW output), the TAKE button will be turned off (not illuminated) momentarily (until the unit successfully locks to this input). The TAKE button should not be pressed until it lights up again, otherwise there will be a period of black during the transition

8.2.1 The Transition from Preview to Program

The transition can occur in one of two modes¹:

- The Follow mode (shown in Figure 9) in which the PROGRAM input button is switched to the same position as the PREVIEW input button after the TAKE button is pressed
- The Swap mode, in which the PREVIEW input buttons and the PROGRAM input buttons switch places after pressing the TAKE button. For example, in Figure 9 the PROGRAM input button 3 would switch to 2 and the PREVIEW input button 2 would switch to 3, so the RGBS source is displayed on the PROGRAM screen and the HD Component source is displayed on the PREVIEW screen.

8.3 Switching/Scaling of an Input

The **VP-727xl** scales the selected sources² to HDMI, RGBHV or YUV and VGA simultaneously. It switches seamlessly between sources using the selected special effects, which include cuts, fades, and wipes. Select the appropriate source (from channel 1 to 8) via the Input command in both the Preview Setting OSD screen and/or the Program Setting OSD screen (see section 9.1.1), via the IR or front panel pushbuttons, or via the serial or Ethernet control.

8.4 Understanding the PIP Button Feature

The Picture-in-Picture inserter (PIP) is used for the simultaneous display of video and graphic sources³, and lets you display an inserted video PIP source over a graphic source⁴, or an inserted graphic PIP source over a video source⁵.

8.4.1 Selecting the PIP Source

Select the PIP source (from channel 1 to 8), via the PIP source command in both the Preview Setting OSD screen and/or the Program Setting OSD screen.

1 As selected via the Transition OSD Menu, see section 9.1.2

2 Composite video, s-Video, component video (sometimes called YUV or Y, B-Y, R-Y or Y, Pb, Pr), RGB/YUV, RGBS, RGsB, or RGBHV

3 Since the HDMI signal is HDCP protected, an HDMI signal cannot appear on a display that is not HDCP compliant

4 For example, a composite video, s-Video, or component (video) video PIP source inserted over a component (graphics), RGB/YUV, RGBS, RGsB, or RGBHV graphic source

5 For example, a component (graphics), RGB/YUV, RGBS, RGsB, or RGBHV graphic PIP source inserted over a composite video, s-Video, or component (video) video source

8.4.2 Activating the PIP

To activate the PIP (which illuminates the PIP button), do one of the following:

- Press the PIP button
- Switch on the PIP functionality via the OSD Menu
- Press the PIP key on the remote control transmitter (see Figure 24)
- Select PIP via the serial or the Ethernet port

8.4.3 PIP Characteristics

You can determine the following PIP characteristics:

- PIP Source
- PIP Size (1/25, 1/16, 1/9, 1/4, split screen, or custom¹). Via the Preview Setting PIP OSD menu, you can resize the PIP
- Horizontal and Vertical position, placing it anywhere on the screen. To move the location of the PIP, reset the PIP position in the Preview Setting PIP OSD menu
- You set the custom PIP size via the H-Size and V-Size settings in the Preview Setting PIP OSD menu

8.5 Locking and Unlocking the Front Panel

To prevent changing the settings accidentally or tampering with the unit via the front panel buttons, lock your **VP-727xl**. Unlocking releases the protection mechanism. When the front panel is locked, control is still available via RS-232, the ETHERNET, and/or the CONTROL connector.

To lock the **VP-727xl**:

- Press and hold for a few seconds the PANEL LOCK button² on the front panel
The front panel is locked and the PANEL LOCK button is illuminated.
Pressing a button will have no effect

To unlock the **VP-727xl**:

- Press and hold for a few seconds the illuminated PANEL LOCK button² on the front panel
The front panel unlocks and the PANEL LOCK button is no longer illuminated

For a description of the Save Lock and Input Lock OSD functions, see section 9.1.4.2.

¹ You set the custom PIP size via the H-Size and V-Size settings in the Preview Setting PIP OSD menu

² Or the Lock key on the infra-red remote control transmitter (see Figure 24)

8.6 Using Text Overlay

The text overlay feature is accessed via the Application Program (AP)¹.

Running this AP with the PC connected to the **VP-727xl** lets you display text over the screen, with a rich feature set including text color and speed, transparency, text position and repetition. Current text overlay settings can be saved and loaded to the AP.

Before running this program, you have to close the Ethernet Application program.

Figure 10 and Table 3 define the TextOverlay Application Screen:

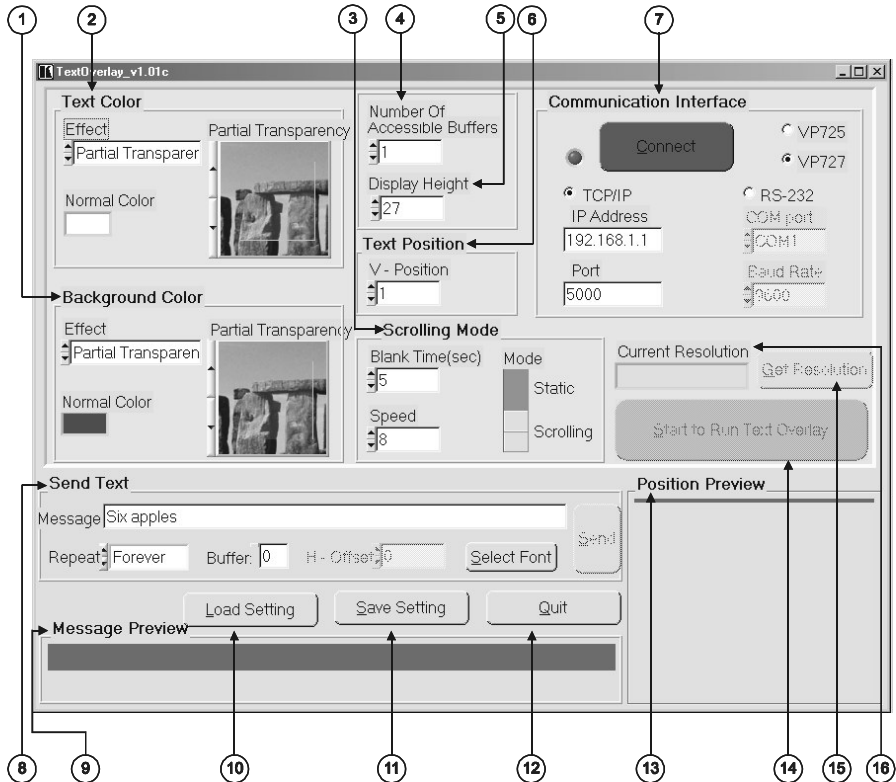

Figure 10: TextOverlay Application Screen

¹ You can download it from our Web site: <http://www.kramerelectronics.com>

Table 3: Features and Functions of the TextOverlay Application

#	Feature	Function	
1	Background Color	Effect ¹	Set to <i>Normal</i> for a solid colored background; Set to <i>Partial Transparency</i> for a partially transparent background Set to <i>Full Transparency</i> for a transparent background
		Partial Transparency	Select the partial transparency shade
		Normal Color	Select the background color
2	Text Color	Effect ¹	Set to <i>Normal</i> for solid colored text; Set to <i>Partial Transparency</i> for partially transparent text; Set to <i>Full Transparency</i> for transparent text (can be seen over a solid background)
		Partial Transparency	Select the partial transparency shade
		Normal Color	Select the text color
3	Scrolling Mode	Blank Time	Set the blank delay time
		Speed	Set the speed at which the text moves on the display
		Mode	Set to <i>Static</i> (fixed text) or <i>Scrolling</i> (text moves across the display)
4	Number of Accessible Buffers	Set the number of messages you can send one after the other (from 1 to 3). The number of buffers limit the display height in relation to the output resolution, as defined in Table 4	
5	Display Height	Set the thickness of the background stripe (height value is limited by the <i>Number of Accessible Buffers</i> and the output resolution, see Table 4)	
6	Text Position – V-Position	Set the vertical position of the text background on the display screen	
7	Communication Interface	Connect/Disconnect	Connect the machine or disconnect
		TCP/IP Check box	When selected, set the <i>IP Address</i> and <i>Port</i> to connect via Ethernet ²
		RS-232 Check box	When selected, set the <i>COM port</i> and <i>Baud Rate</i> (115200 for VP-727) to connect via the RS-232 connector ²
		VP725 Check box	Select VP725 when connected to a VP-725 series machine
		VP727 Check box	Select VP727 when connected to a VP-727xl (or VP-727) machine
8	Send Text	Message	Type the desired text in the <i>Message</i> box
		Repeat	Set the number of times that the text message will scroll across the screen ³ (1 to 20), or set to <i>Forever</i> to repeat the text message continuously
		Buffer	Depending on the <i>Number of Buffer</i> , you can have up to 3 different text messages running over the background
		H-Offset	After selecting the <i>Static</i> mode, use the <i>H-Offset</i> box to select the horizontal position of the text
		Select Font	Press to select the font and the font size. The text will change on the screen only after pressing the <i>Send</i> button
		Send	Transmits the message to be displayed on the screen
9	Message Preview	Press to show how the text overlay will look	
10	Load Setting	Press to load a previously saved setting	
11	Save Setting	Press to save the current setting	
12	Quit	Closes the program	
13	Position Preview	View the position of the text overlay (adjust via <i>V-Position</i> selector)	
14	Start to Run Text Overlay	Press to display the text on screen. The green button becomes a yellow "Stop Text Overlay" button. Press to stop scrolling on screen	
15	Get Resolution	Press to read the current output resolution	
16	Current Resolution	Displays the current output resolution	

1 Unavailable after pressing the "Start to Run Text Overlay" button

2 You have to select the connection type before connecting the software to the machine

3 For example, set to 2 to repeat the text twice

Table 4: Number of Buffers, Output Resolution and Maximum Display Height

Output Resolution	Maximum Display Height According to Number of Buffers		
	1	2	3
640x480	54	36	27
800x600	43	29	21
832x624	42	28	21
852x480	41	27	20
1024x768	34	22	17
1280x720	27	18	13
1280x768	27	18	13
1280x1024	27	18	13
1366x768	25	17	12
1365x1024	25	17	12
1400x1050	25	16	12
1600x1200	21	14	10
480P	48	32	24
576P	48	32	24
720P	27	18	13
1080i	18	12	9
1080p	18	12	9

8.6.1 Downloading the TextOverlay Program

To use the TextOverlay Application, download the Text Overlay software from our Web site¹ and follow the on-screen instructions.

8.6.2 Setting the Text Message

The text overlay parameters can be set before or after pressing the red Connect button.

You can set the following parameters:

- Type the required text in the Message box and press Send
- Select the Background Color items and the Text Color items, including the Effect, the Normal Color and the Partial Transparency
- Select the Number of Buffer and the Display Height
- Set the V-Position
- Set the *Blank Time* and the scrolling *Speed*
- Set the Mode to Static or Scrolling
- If in the *Static* mode, set the text *H – Offset*
- If required, select the *Buffer* option² (0 to 2) to send varying text messages

¹ Go to <http://www.kramerelectronics.com>

² This option can be used only if the Number of Buffer is other than 1

- Select the *Repeating* frequency (1 to 20 or Forever)
- Select the *Font* and Font size

Table 5 describes when the setup parameters are available:

Table 5: TextOverlay Parameters

The Parameter	Before “Start to Run TextOverlay”	Needs Send?
Number of accessible buffers	Yes	
Display height	Yes	
Mode selection ¹	Yes	
Text Color Effect	Yes	
Background Color Effect	Yes	
Get resolution	Yes	
Normal Color (Text Color)		No
Normal Color (Background Color)		No
V-Position (Text Position)		No
Blank Time (sec)		No
Speed		No
Message		Yes
Repeat		Yes
Buffer		Yes
H-Offset		Yes
Select Font		Yes

8.6.3 Connecting and Disconnecting the TextOverlay Program

To connect the TextOverlay program, do the following:

1. Open the TextOverlay program.
The TextOverlay application screen appears².
2. Select the **VP-727xl** check box.
3. Select the type of connection to be used³. When selecting:
 - RS-232, in the COM port box select the COM port you want to use and in the Baud Rate box, select 115200
 - TCP/IP, in the IP Address box, type the machine IP and in the Port box type the port you want to use
4. Press the red “Connect” button.
Once a connection is established, the red “Connect” button changes to a green “Disconnect” button, and the connection type boxes are disabled.

¹ Static or Scrolling

² If required, you can load a previously saved setting and continue to step 4 in this procedure

³ If you are loading a previously saved setting, the type of connection is already defined

5. If required, type the text in the message box, and edit the text message (see section 8.6.2).
6. Press the green “Start to run Text Overlay” button.
The green button changes to a yellow “Stop Text Overlay” button.
7. Click the Send button in the Send Text area.
Text starts running over the display.

If you need to change any of the settings while the text message is running, do so according to section 8.6.2.

To disconnect the TextOverlay program, press the green Disconnect button or press the Quit button to exit the program.

8.6.4 Saving and Loading Settings

You can save current settings at any time or load a previously saved setting. When loading a setting¹, the TextOverlay program automatically disconnects and you need to reconnect it.

¹ A saved setting also includes the connection type (TCP/IP or RS-232)

9 Operating the VP-727xl

You can operate the **VP-727xl** via the:

- OSD Menu, see section 9.1
- LCD Display, see section 9.2
- Infra-red Remote Control Transmitter, see section 9.3
- ETHERNET, see section 9.4
- RS-232, see section 9.5

9.1 Operating via the OSD MENU Screen

The OSD superimposes a menu on the Preview screen from which you can control your **VP-727xl**. When the OSD front panel button is on, pressing the *MENU* button on the front panel or the Menu key on the infra-red remote control transmitter displays the first OSD screen¹, the “Preview Setting” screen. If the OSD is off, pressing the *MENU* button on the front panel or the Menu key on the infra-red remote control transmitter will not display the “Menu screen”. In this case, you can navigate via the front panel LCD. Figure 11 defines the five interactive icons each representing a Level 1 function:



Figure 11: Menu Screen Icons

9.1.1 Preview and Program Setting Commands

Figure 12 and Table 6 define the Preview and Program Setting commands:

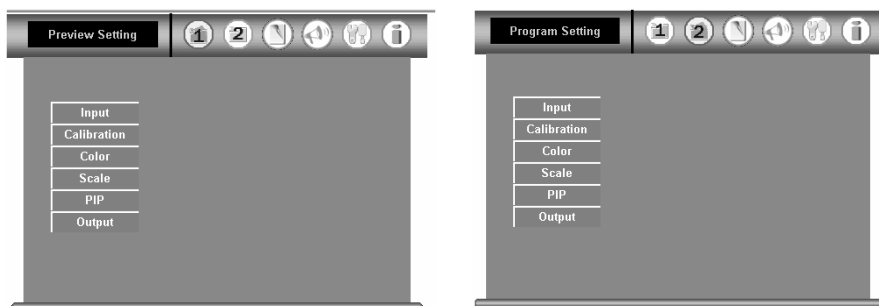

Figure 12: Preview and Program Setting OSD Menus

¹ Or the last used OSD screen

Table 6: Preview and Program Setting OSD Menus

Level 1	Level 2	Level 3	Range	Default
Input	Source	Channel 1 to 8 (selects the input source)		
	Type	RGBHV, RGBS (PC/Video), RGsB (PC/Video), HD Component, SD Component, Y/C or CV (selects the input signal type) HDMI (for input 1 and input 2 only)		
	Video Standard	Auto, NTSC, PAL, PAL-M, PAL Comb.-N, NTSC 4.43, SECAM or PAL 60 (selects the Video standard)		
	De-Interlace	Dynamic, Static (only for Type = HD Component / HDMI)		
Calibration	See section 9.1.1.1			
Color	ICC1 Red	Adjusts the red color	0 to 30	15
	ICC1 Green	Adjusts the green color	0 to 30	15
	ICC1 Blue	Adjusts the blue color	0 to 30	15
	ICC1 Yellow	Adjusts the yellow color	0 to 30	15
	Gamma	Adjusts the gamma	0 to 30	15
	Color Temp.	Adjusts the color temperature	-32 to 32	0
Scale	Aspect Ratio Adjustment	Aspect Ratio (selects the scaler mode): Anamorphic (displays the aspect ratio - usually 16:9), Virtual Wide (anamorphic plus non-linear scaling), Letterbox (the vertical line is expanded to full screen), Native (lets you set the native resolution according to the specifications of the plasma screen or projector), 4:3 Output (the width to height ratio is 4:3), or User Define		
		Location (selects the native mode): Left + Up, Right + Up, Center, Left + Down, or Right + Down		
		H-Zoom		0
		V-Zoom		0
		H-Pan		0
	V-Pan		0	
	Zoom Adjustment	Zoom Ratio: Off, 150%, 200%, 225%, 250%, 275%, 300%, 325%, 350%, 375% or 400% (selects the zoom ratio)		
		H-Pan	-64 to 64	0
V-Pan		-64 to 64	0	
PIP	On/Off	On/Off		
	Source	Channel 1 to 8 (selects the PIP source)		
	Size	1/25, 1/16, 1/9, 1/4, Split, Custom		
	H-Size	Set custom size	1 to 255	128
	V-Size	Set custom size	1 to 255	128
	H-Position	Set the horizontal position of the PIP on the display	-32 to 32	-32
	V-Position	Set the vertical position of the PIP on the display	-32 to 32	-32
Output	Resolution	640x480, 800x600, 832x624, 852x480, 1024x768, 1280x720, 1280x768, 1280x1024, 1366x768, 1365x1024, 1400x1050, 1600x1200, 480p, 576p, 720p, 1080i, 1080p or user define		
	Refresh Rate	50Hz, 60Hz, 75Hz or Frame Lock (based on chosen resolution)		
	Test Pattern	Off, 32 Gray Ramp, Sharpness, Red, Green, Blue, White, Black, Chessboard, Color Bar, Aspect Ratio, RGB Gray Ramp, Gamma Check (see section 9.1.1.1)		
	Confirm/Discard	Confirms the action / cancels the action		
	User Mode Setting	Values will be used when user define is selected as output resolution (see section 9.1.1.3)		

1 Independent Color Control

9.1.1.1 Preview / Program Setting Calibration Screens

The Preview/program setting calibration screens are defined either for HDMI and RGBHV signals (see Figure 13 and Table 7), or for CV and component video signals (see Figure 14 and Table 8).

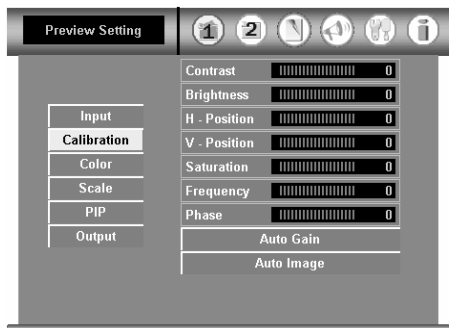

Figure 13: Preview Setting Calibration Menu (for HDMI and RGBHV signals)

Table 7: Preview Setting Calibration Menu

Level 1	Level 2	Level 3	Range	Default
Calibration	Contrast	Adjust the contrast	-32 to 32	0
	Brightness	Adjust the brightness	-32 to 32	0
	H-Position	Adjust the H-position	-50 to 50	0
	V-Position	Adjust the V-position	-20 to 40	0
	Saturation	Adjust the saturation	-32 to 32	0
	Frequency	Adjust the frequency	-50 to 50	0
	Phase	Adjust the pixel phase	0 to 31	?
	Auto Gain	Auto-adjust gain settings		
	Auto Image	Auto adjust frequency, H position, V position and phase		

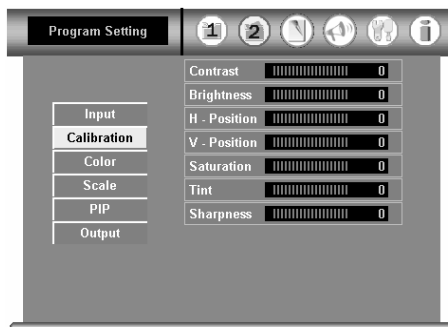

Figure 14: Program Setting Calibration Menu

Table 8: Program Setting Calibration Menu

Level 1	Level 2	Level 3	Range	Default
Calibration	Contrast	Adjust the contrast	-32 to 32	0
	Brightness	Adjust the brightness	-32 to 32	0
	H-Position	Adjust the H-position	-50 to 50	0
	V-Position	Adjust the V-position	-20 to 40	0
	Saturation	Adjust the saturation	-32 to 32	0
	Tint	Adjust the tint	-32 to 32	0
	Sharpness	Adjust the sharpness	-32 to 64	0

9.1.1.2 Preview / Program Setting Output Test Pattern Screens

Figure 15 illustrates the Test Pattern screens¹:

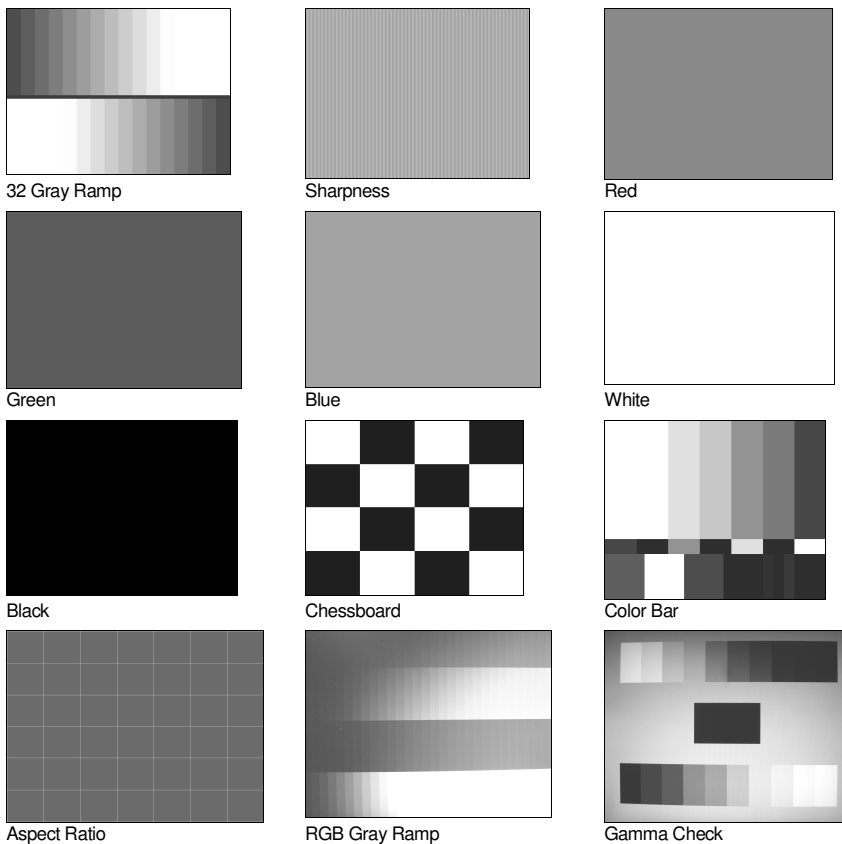

Figure 15: Test Pattern Screens

¹ When selected, the test pattern is displayed after exiting from the OSD menu

9.1.1.3 Preview / Program User Mode Output Setting

Figure 16 and Table 9 define the parameters of the User Mode Setting¹.

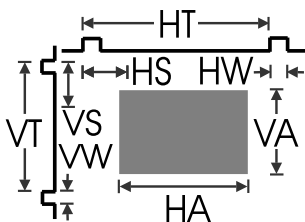

Figure 16: User Mode Setting

Table 9: User Mode Setting Definitions

User Mode Setting Definitions	
HT:	Horizontal total
HW:	Horizontal sync pulse width
HS:	Horizontal active start point
HA:	Horizontal active region
HP:	Horizontal polarity
VT:	Vertical total
VW:	Vertical sync pulse width
VS:	Vertical active start point
VA:	Vertical active region
VP:	Vertical polarity
OCLK:	Output clock
Delay:	Delay
Set Current:	Import the values of the currently selected output resolution into the User Mode Setting

¹ These values will be used when "User Define" is selected as the output resolution

9.1.2 Transition Commands

Figure 17 illustrates the Transition screen:

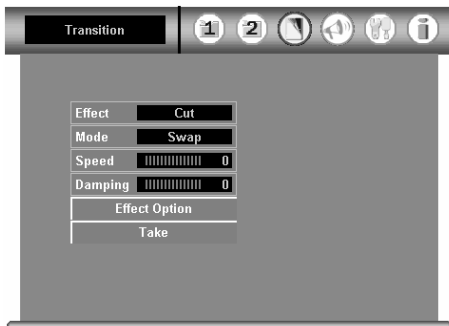
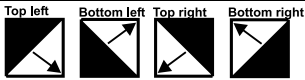
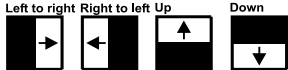
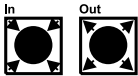
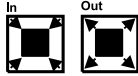
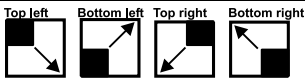
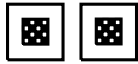

Figure 17: Transition OSD

Set the transition direction via the Transition Effect Option, as Table 10 defines:

Table 10: Transition Effect Option Commands

Level 1	Level 2	Level 3
Effect	Cut, Fade, Diagonal, Wipe, Circle, Square, Corner, Chessboard	
Mode	Swap, Follow	
Speed	Range: 1 to 5; Default: 3	
Damping	Range: 0 - 4	
Effect Option	Diagonal	Top left, Bottom left, Top right, Bottom right 
	Wipe	Left to right, Right to left, Up, Down 
	Circle	In, Out 
	Square	In, Out 
	Corner	Top left, Bottom left, Top right, Bottom right 
	Chessboard	In, Out  <p>Each block performs as shown in the "Square" above</p>
Take		

9.1.3 Audio Settings Commands

Figure 18 and Table 11 define the Audio Setting screen:



Figure 18: Audio Setting OSD

Table 11: Audio Setting OSD Menus

Level 1	Level 2	Level 3	Range	Default
Program	Source	Channel 1 to 8 (selects the input source)		
	Input Volume		-82 (mute) to +45	0
	Output Volume		-22 (mute) to +9	0
	Delay		0 to +127	0
Preview	Source	Channel 1 to 8 (selects the input source)		
	Input Volume		-82 (mute) to +45	0
	Output Volume		-22 (mute) to +9	0
Headphones	Source	Program or preview		
	Volume		-11 to +4	
Calibration	Bass		-6 to +6	
	Treble		-6 to +6	
	Balance		-10 to +10	
Option	Audio-Follow-Video	Audio follow video: follow, audio breakaway		
	Fade	ON or OFF		
Take	Pressing causes the transition from preview to program (SWAP or FOLLOW)			

9.1.4 Utility Commands

Figure 19 and Table 12 define the Utility screen:

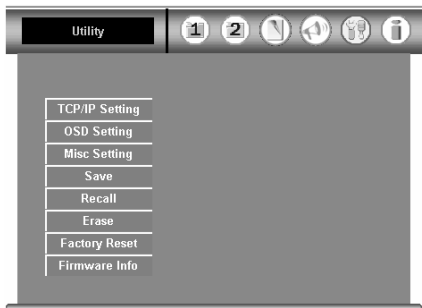

Figure 19: Utility OSD

Table 12: Utility OSD Setting

Level 1	Level 2	Level 3 / Range
TCP/IP Setting (see section 9.1.4.1)	DHCP	On/Off
	IP Address	
	Subnet Mask	
	Gateway	
	Apply	
OSD Setting ¹	Size	Normal, Double
	H-Position	-32 to 32 0
	V-Position	-32 to 32 0
	Time Out	3 to 60 or OFF ² 20
Misc. Setting (see section 9.1.4.2)	Logo	On/Off
	Save Lock	On/Off
	Input Lock	On/Off
	Background	Black/Blue
	Blank Color	Black/Blue
	Event Mode	On/Off
	Baud Rate	9600/115200
Save	(see section 9.1.4.3)	Setting 1 to 8 Saves the setting
Recall		Setting 1 to 8 Recalls the setting
Erase		Setting 1 to 8 Erases one setting or all the settings
Factory Reset	Cancel/OK	
Firmware Info	Displays the firmware versions	

¹ For configuring the parameters of the OSD (on-screen display) window

² Setting the Time Out to OFF will display the OSD continuously, until you manually close it

9.1.4.1 TCP/IP Setting Commands

Figure 20 and Table 13 define the TCP/IP Setting screen:

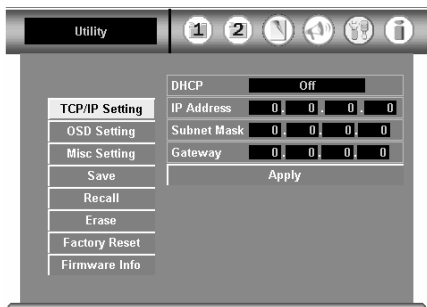

Figure 20: TCP/IP Setting OSD

Table 13: TCP/IP Setting OSD

Feature	Function
DHCP ¹	Allows the network administrator to distribute IP addresses from a central point and automatically send a new IP address when an Ethernet point is plugged into a different network location
IP Address	A 32-binary digit number that identifies each sender or receiver (within a network via a particular server or workstation) of data (HTML pages or e-mails) that is sent in packets across the Internet
Subnet Mask	Allows the packet that arrives at the gateway with its unique network number to be routed within the organization's internal gateways
Gateway	A network position serving as an entry to another network. On the Internet, a node or stopping point can be either a gateway node or a host (end-point) node

9.1.4.2 Misc Setting Commands

The Misc Setting (illustrated in Figure 21) includes the Logo, Save Lock, Input Lock, Background Blank Color, Event Mode (OFF/ON) and Baud Rate (9600/115200) commands.

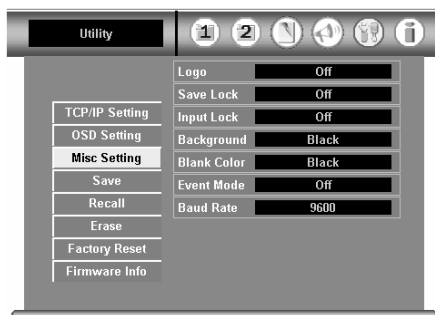

Figure 21: Misc Setting OSD

9.1.4.2.1 Logo

You can set the Kramer logo On or Off. When set to On (the default), it is displayed for 20 seconds upon initialization. If set to Off, it is disabled.

¹ Dynamic Host Configuration Protocol

9.1.4.2.2 Save Lock

The Save Lock complements the Panel Lock¹. When set to On, the Save Lock function is used to select whether the status of the Panel lock is saved on power down, and then recalled when the unit is turned on again².

9.1.4.2.3 Input Lock

The Input Lock complements the Panel Lock¹. When set to On, the Input Lock function is used to select whether the 8x2 Input buttons and the TAKE button are included in the buttons which are locked³.

9.1.4.3 Save/Recall/Eraser Setting Commands

You can save/recall/ up to 8 settings. In each setting you can preserve the entire machine's settings⁴. All parameters are saved/recalled, including the Universal Input configurations, ProcAmp settings, output resolutions, and so on. You can also erase a single setting or all of them.

9.1.5 Information Screen

The Information screen (see Figure 22) shows information regarding the Preview and Program sources; the PIP sources; the output resolutions; and firmware versions.

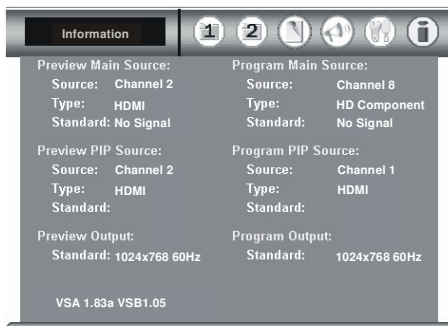

Figure 22: Information OSD

1 For a description of how to lock the front panel using the PANEL LOCK button, see section 8.5

2 If the Save Lock is OFF, the Panel Lock will be OFF when the machine is powered up (even if the Panel Lock was ON before the power was turned OFF)

3 If the Input Lock is ON, access to the front panel buttons is blocked when Panel Lock is On, including the PROGRAM and PREVIEW INPUT selector front panel buttons, and the Program and Preview IR remote transmitter keys. When Input Lock is Off, then you can still access the 8x2 Input buttons and the TAKE button, even if the Panel Lock is On

4 This is useful, for example, for configuring the machine for multiple presentations. Up to 8 presentation configurations can be saved in the machine's memory

9.2 Operating via the Front Panel LCD Display

You can control the **VP-727xl** PREVIEW output from the front panel high contrast LCD Display, using the:

- Front panel OSD buttons: *MENU*, *ENTER*, *▶*, *◀*, *▲*, and *▼*
- Infra-red remote control transmitter (see Figure 24) keys: *MENU*, and the direction keys

For example, to set the time out to 60 seconds via the LCD Display, using the front panel buttons, do the following:

1. Turn the **VP-727xl** unit ON, and press the OSD ON button (if selected).
2. Press the appropriate front panel OSD buttons (as defined in Figure 23).

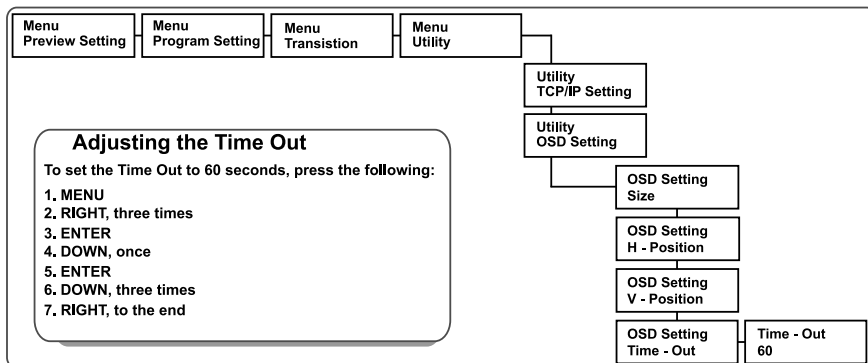

Figure 23: Example of how to use the LCD Display

9.3 Operating via the Infra-red Remote Control Transmitter

You can control the **VP-727xl** remotely, from the infra-red remote control transmitter (that has a range of up to 15 meters and is powered by two AAA size 1.5V DC batteries), as defined in Figure 24 and Table 14:

Figure 24: Remote Transmitter

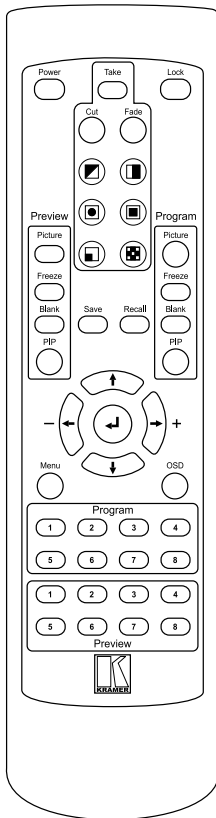

Table 14: Remote Transmitter Functions

Keys	Function	
Power	Cycles power ¹	
Take ²	Pressing <i>TAKE</i> causes the transition to occur	
Lock	Locks/unlocks the front panel	
Cut ³	Selects an instantaneous transition from the PREVIEW output to the PROGRAM output	
Fade	Selects a dissolved transition from the PREVIEW output to the PROGRAM output	
	Selects a Diagonal transition effect ⁴	
	Selects a WIPE transition effect ⁵	
	Selects a CIRCLE transition effect ⁶	
	Selects a SQUARE transition effect ⁶	
	Selects a CORNER transition effect ⁴	
	Selects a CHESSBOARD transition effect ⁶	
Picture	Separate keys for PREVIEW/PROGRAM Outputs	Adjusts the picture contrast, brightness, saturation, auto gain, and auto image
Freeze		Freezes the output video image
Blank		Displays a blank screen
PIP		Selects the picture-in-picture function
Save	Saves the setting	
Recall	Recalls the setting	
Direction	Consists of a set of 5 separate keys that allow maneuvering within an OSD screen	
Menu	Displays the OSD Menu screen (or moves to the previous level in the OSD menu)	
OSD	Activates/deactivates access to the OSD Menu	
Selector	8 separate selector keys for both the Program and the Preview outputs	

1 Puts the machine in standby mode and causes the IR Receiver / LED to light red (instead of green)

2 The effect is only seen in PROGRAM Mode

3 Only for setting up the unit for the effect. The effect will only occur when the Take button is pressed

4 Choose the direction from where the effect starts: "top left", "bottom left", "top right" or "bottom right" (see section 9.1.2)

5 Choose the direction from where the effect starts: "left to right", "right to left", "up" or "down" (see section 9.1.2)

6 Choose the direction from where the effect starts: "in" or "out" (see section 9.1.2)

9.4 Operating via ETHERNET

To control your **VP-727xl** via the Ethernet/Serial Port, connect the ETHERNET port of the **VP-727xl** to the Ethernet port of your PC¹ and then install and configure the Ethernet Application (see section 9.4.1).

9.4.1 Installing and Running the Configuration Software

To install the **VP-727xl** Ethernet Application, do the following:

1. Insert the product CD into your CD-ROM drive².
2. Save the zip file on your computer.
3. Run the installer setup.
4. Respond to the installation wizard prompts.
5. Restart your system.

9.4.2 Configuring the Ethernet Connection

Double click the *VP727 Ethernet AP.exe*³ icon. The *VP727 Ethernet Application* main dialog box appears (see Figure 25), with a configuration tab and a Control tab.

9.4.2.1 The Configuration Screen

Use the Configuration screen to discover the IP address of the device connected to your computer. Figure 25 and Table 15 define the Configuration tab.

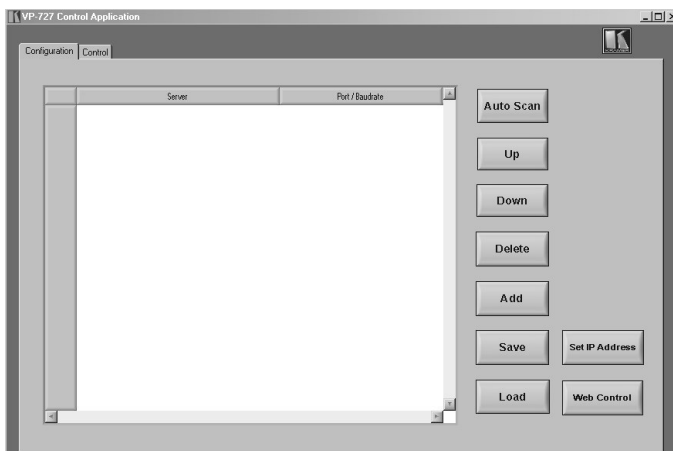

Figure 25: VP727xl Ethernet Application Main Dialog Box (Configuration Tab)

1 Or connect the serial port of your VP-727xl to the serial port of your PC (see section 7.1)

2 Or download the software from our Web site on <http://www.kramerelectronics.com>

3 Even though VP-727 is mentioned in the text, it refers also to VP-727xl

Table 15: VP727xl Ethernet Application Configuration Tab

Button	Function
Autoscan	Press to automatically scan for connected machines
Up	Press to scroll down the Server list
Down	Press to scroll up the Server list
Delete	Press to delete an IP number
Add	Press to manually add an IP Number or set up the RS-232 COM port
Save	Press to save Server settings
Load	Press to load Server settings

To search for devices, click the **Auto Scan** button.

Figure 26 shows a device found on the network, with the IP address assigned at the factory¹.

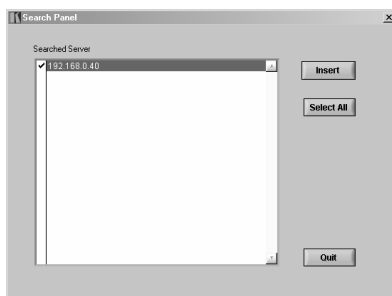

Figure 26: VP727xl Control Application Search Panel Screen

Check your machine IP number, and click **Insert** to accept it.

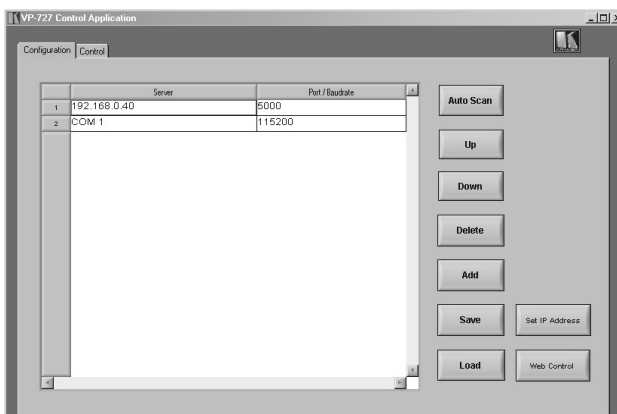

Figure 27: Configuration Tab

¹ You can also set the IP address via the OSD menu, see section 9.1.4.1

To change the IP address of the unit¹:

- Select the device on the list and then right-click it
A selection box appears, stating “Set IP Address” and “Web Control”²
- Select “Set IP Address”, enter the new IP address and click **Update**
The new IP address will appear on the screen

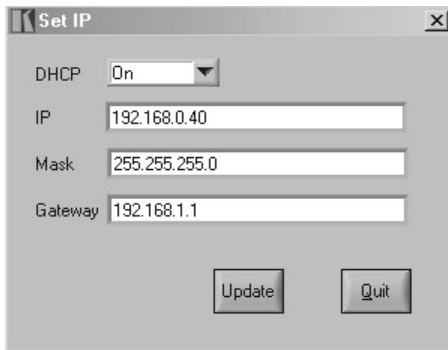

Figure 28: Setting an IP Number

9.4.3 Control the VP-727xl via the Ethernet/Serial Port

To control the **VP-727xl** via the Ethernet, do the following:

1. On the *VP727xl Control Application* screen, click the **Control** tab.
The Control screen appears (see Figure 29).
The Control tab includes a set of control buttons, which enable you to operate and control the machine via the Ethernet or serial ports, according to the configuration.
2. Press one of the eight orange buttons (1 to 8) that appear on the top left side on the screen of the Control tab³.
Control the selected machine via the control buttons on the screen⁴.

1 The default IP address can be changed to fit your network system

2 Pressing the Web Control option lets you access the unit’s Web page from which you can change different parameters, such as the IP address, enable/disable the DHCP client (DHCP is Dynamic Host Configuration Protocol), as well as setting the Baud rate (for example, 9600 or 115200)

3 When a machine is connected, the button lights. Otherwise it is unavailable

4 Button turns green

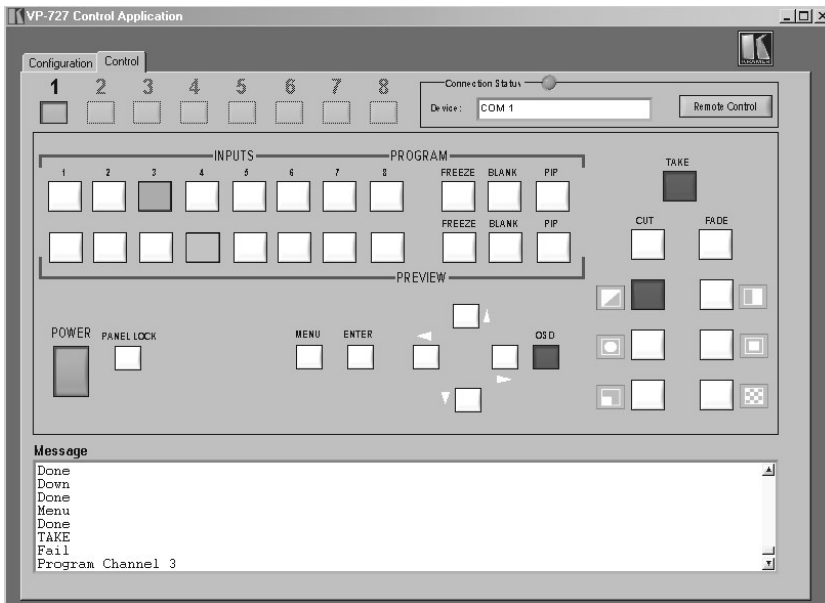

Figure 29: VP727xl Control Application Main Dialog Box (Control Tab)

The Control tab includes:

- All the front panel buttons
- A Connection Status area consisting of a connection indicator and the device IP number or COM port
- A Message area, recording all the operations performed on the machine

When clicking the Kramer icon, on the top right, the AP information appears, including the version number.

By pressing the Remote Control button on the Control tab, you can operate the machine via the virtual remote controller interface, for your convenience.

9.5 Operating via RS-232

You can control the **VP-727xl** via the RS-232 port using the *Kramer VP-727xl Control Application* (see section 9.4.3).

10 Technical Specifications

Table 16 includes the technical specifications:

Table 16: Technical Specifications¹ of the VP-727xl

INPUTS:	2 HDMI connectors (HDMI version 1.2 and HDCP version 1.2) 8 sets of universal BNC connectors: R/Pr, G/Y/CV, B/Pb/C, Hs/Cs, and Vs, each programmable for use as CV, YC, RGB, YCbCr, YPbPr, RGBS or RGBHV
PREVIEW OUTPUT:	1 x HDMI connector (HDMI version 1.2 and HDCP version 1.2) 1 x VGA (VGA through UXGA) on an HD15F connector 1 x RGBHV / YPbPr on BNC connectors
PROGRAM OUTPUT:	1 x HDMI connector (HDMI version 1.2 and HDCP version 1.2) 1 x VGA (VGA through UXGA) on an HD15F connector 1 x RGBHV / YPbPr on BNC connectors
CONTROLS:	Front panel buttons, high contrast LCD, IR remote control, ETHERNET, AUDIO CONTROL, RS-232, RS-485, and optional T-bar remote controller
ADDITIONAL CONTROLS:	Freeze, zoom, different selectable vertical refresh rates, ProcAmp control, output image scaling, Picture-In-Picture, text overlay, and aspect ratio change
POWER SOURCE:	100-240 VAC, 50/60Hz 55VA
DIMENSIONS:	19" (W), 9.3" (D), 3RU (H) rack mountable
WEIGHT:	5.5 kg. (12.2 lbs.) approx.
ACCESSORIES:	IR remote control, power cord
OPTIONS:	Control panel

¹ Specifications are subject to change without notice

11 VP-727xl Communication Protocol

This addendum includes the Communication Protocol for the **VP-727xl**:

Set and Get command:

Set Command:

Y■Control_Type■Function■Param 1■.....■Param N■CR

Reply:

Z■Control_Type■Function■Param 1■.....■Param N■CRDoneCR

Get Command:

Y■Control_Type■Function■CR

Example

1. "Y■0■45■32■CR" -> set Preview Contrast value as 32
"Z■0■45■32■CR"
">CR" --> command setting success
2. "Y■1■78■CR" -> get current Preview output resolution
"Z■1■78■2■CR" -> current Preview resolution is 832x624

Definition:

■: ASCII Code 0x20

CR: ASCII Code 0xD or 0xA

After set type Command setting, system will respond with a string.

Baud rate: 115200bps, Start Bit: 1Bit, Data Bit: 8Bit, Parity Bit: NA, and Stop Bit: 1Bit.

Table 17 defines the Set Commands:

Table 17: Set Commands¹

Control Type		F	Param1	Function Description
Set	Get			
0	-	0	-	Power
0	-	1	-	Panel Lock
0	-	2	-	Take
0	-	3	-	Cut
0	-	4	-	Fade
0	-	5	-	Diagonal
0	-	6	-	Wipe
0	-	7	-	Circle
0	-	8	-	Square
0	-	9	-	Corner
0	-	10	-	Chessboard
0	-	11	-	Preview Picture
0	-	12	-	Preview Freeze
0	-	13	-	Preview Blank
0	-	14	-	Preview PIP
0	-	15	-	Program Picture
0	-	16	-	Program Freeze
0	-	17	-	Program Blank
0	-	18	-	Program PIP
0	-	19	-	Up
0	-	20	-	Down
0	-	21	-	Left
0	-	22	-	Right
0	-	23	-	Menu
0	-	24	-	Enter
0	-	25	-	OSD
0	-	26	-	Program Ch1
0	-	27	-	Program Ch2
0	-	28	-	Program Ch3
0	-	29	-	Program Ch4
0	-	30	-	Program Ch5
0	-	31	-	Program Ch6
0	-	32	-	Program Ch7
0	-	33	-	Program Ch8
0	-	34	-	Preview Ch1
0	-	35	-	Preview Ch2
0	-	36	-	Preview Ch3
0	-	37	-	Preview Ch4
0	-	38	-	Preview Ch5
0	-	39	-	Preview Ch6
0	-	40	-	Preview Ch7
0	-	41	-	Preview Ch8
0	1	42	0: Channel 1; 1: Channel 2; 2: Channel 3; 3: Channel 4; 4: Channel 5; 5: Channel 6; 6: Channel 7; 7: Channel 8	Preview Input Source
0	1	43	0: RGBHV; 1: RGBS(PC); 2: RGSB(PC); 3: ED/HD Component 4: SD Component; 5: RGBS(Video); 6: RGSB(Video); 7: Y/C; 8: Video; 9: HDMI	Program Input Type * HDMI type can only be selected for Channel 1 or Channel
0	1	44	0: Auto; 1: NTSC; 2: PAL; 3: PAL-M; 4: PAL-N; 5: NTSC 4.43; 6: SECAM; 7: PAL 60	Preview Input Video Standard
0	1	45	-32 ~ 32	Preview Calibration Contrast
0	1	46	-32 ~ 32	Preview Calibration Brightness

¹ F = Function

VP-727xl Communication Protocol

Control Type		F	Param1	Function Description
Set	Get			
0	1	47	-	Preview Calibration H-Position
0	1	48	-	Preview Calibration V-Position
0	1	49	-32 ~ 32	Preview Calibration Saturation
0	1	50	-50 ~ 50	Preview Calibration Frequency
0	1	51	0 ~ 31	Preview Calibration Phase
0	-	52	-	Preview Calibration Auto Gain
0	-	53	-	Preview Calibration Auto Image
0	1	54	-32 ~ 32	Preview Calibration Tint
0	1	55	-32 ~ 64	Preview Calibration Sharpness
0	1	56	0 ~ 30	Preview Color ICC R
0	1	57	0 ~ 30	Preview Color ICC G
0	1	58	0 ~ 30	Preview Color ICC B
0	1	59	0 ~ 30	Preview Color ICC Y
0	1	60	0 ~ 30	Preview Color Gamma
0	1	61	-32 ~ 32	Preview Color Temp
0	1	62	0: Off; 1: 150%; 2: 200%; 3: 225%; 4: 250%; 5: 275%; 6: 300%; 7: 325%; 8: 350%; 9: 375%; 10: 400%	Preview Scale Zoom Ratio
0	1	63	-64 ~ 64	Preview Scale Zoom H-Pan
0	1	64	-64 ~ 64	Preview Scale Zoom V-Pan
0	1	65	0: Anamorphic; 1: Virtual Wide; 2: Letterbox; 3: Native; 4: 4:3 Output; 5: User define	Preview Scale Aspect Ratio
0	1	66	0: Left + Up; 1: Right + Up; 2: Center; 3: Left + Down; 4: Right + Down	Preview Scale Native Location
0	1	67	-32 ~ 32	Preview Scale Aspect Ratio Hor Zoom
0	1	68	-32 ~ 32	Preview Scale Aspect Ratio Ver Zoom
0	1	69	-32 ~ 32	Preview Scale Aspect Ratio Hor Pan
0	1	70	-32 ~ 32	Preview Scale Aspect Ratio Ver Pan
0	1	71	0: Off; 1: On	Preview PIP On/Off
0	1	72	0: Channel 1; 1: Channel 2; 2: Channel 3; 3: Channel 4; 4: Channel 5; 5: Channel 6; 6: Channel 7; 7: Channel 8	Preview PIP Source
0	1	73	0: 1/25; 1: 1/16; 2: 1/9; 3: 1/4; 4: Split; 5: Custom	Preview PIP Size
0	1	74	1 ~ 255	Preview PIP H-Size
0	1	75	1 ~ 255	Preview PIP V-Size
0	1	76	-32 ~ 32	Preview PIP H-Position
0	1	77	-32 ~ 32	Preview PIP V-Position
0	1	78	0: 640x480; 1: 800x600; 2: 832x624; 3: 852x480; 4: 1024x768; 5: 1280x720; 6: 1280x768; 7: 1280x1024; 8: 1366x768; 9: 1365x1024; 10: 1400x1050; 11: 1600x1200; 12: 480p; 13: 576p; 14: 720p; 15: 1080i; 16: 1080p; 17: User define	Preview Output Resolution
0	1	79	0: 50; 1: 60; 2: 75	Preview Output Refresh Rate
0	1	80	0: Off; 1: 32 Gray Ramp; 2: Sharpness; 3: Red; 4: Green; 5: Blue; 6: White; 7: Black; 8: Chessboard; 9: Color Bar; 10: Aspect Ratio; 11: RGB Gray Steps; 12: Gamma Check	Preview Output Test Pattern
0	1	81	1 ~ 4095	Preview Output User Mode HT
0	1	82	1 ~ 511	Preview Output User Mode HW
0	1	83	1 ~ 511	Preview Output User Mode HS
0	1	84	1 ~ 2047	Preview Output User Mode HA
0	1	85	0: -; 1: +	Preview Output User Mode HP
0	1	86	1 ~ 4095	Preview Output User Mode VT
0	1	87	1 ~ 31	Preview Output User Mode VW
0	1	88	1 ~ 127	Preview Output User Mode VS
0	1	89	1 ~ 2047	Preview Output User Mode VA
0	1	90	0: -; 1: +	Preview Output User Mode VP

VP-727xl Communication Protocol

Control Type		F	Param1	Function Description
Set	Get			
0	1	91 ¹	6 ~ 200	Preview Output User Mode OCLK
0	1	92	0 ~ 255	Preview Output User Mode Delay
0	-	93	-	Preview Output User Mode SetCurrent
0	1	94	0: Channel 1; 1: Channel 2; 2: Channel 3; 3: Channel 4; 4: Channel 5; 5: Channel 6; 6: Channel 7; 7: Channel 8	Program Input Source
0	1	95	0: RGBHV; 1: RGBS(PC); 2: RGSB(PC); 3: ED/HD Component; 4: SD Component; 5: RGBS(Video); 6: RGSB(Video); 7: Y/C; 8: Video; 9: HDMI	Program Input Type * HDMI type can only be selected for Channel 1 or Channel 2
0	1	96	0: Auto; 1: NTSC; 2: PAL; 3: PAL-M; 4: PAL-N; 5: NTSC 4.43; 6: SECAM; 7: PAL 60	Program Input Video Standard
0	1	97	-32 ~ 32	Program Calibration Contrast
0	1	98	-32 ~ 32	Program Calibration Brightness
0	1	99	-	Program Calibration H-Position
0	1	100	-	Program Calibration V-Position
0	1	101	-32 ~ 32	Program Calibration Saturation
0	1	102	-50 ~ 50	Program Calibration Frequency
0	1	103	0 ~ 31	Program Calibration Phase
0	-	104	-	Program Calibration AutoGain
0	-	105	-	Program Calibration AutoImage
0	1	106	-32 ~ 32	Program Calibration Tint
0	1	107	-32 ~ 64	Program Calibration Sharpness
0	1	108	0 ~ 30	Program Color ICC R
0	1	109	0 ~ 30	Program Color ICC G
0	1	110	0 ~ 30	Program Color ICC B
0	1	111	0 ~ 30	Program Color ICC Y
0	1	112	0 ~ 30	Program Color Gamma
0	1	113	-32 ~ 32	Program Color Color Temp
0	1	114	0: Off; 1: 150%; 2: 200%; 3: 225%; 4: 250%; 5: 275%; 6: 300%; 7: 325%; 8: 350%; 9: 375%; 10: 400%	Program Scale Zoom Ratio
0	1	115	-64 ~ 64	Program Scale Zoom H-Pan
0	1	116	-64 ~ 64	Program Scale Zoom V-Pan
0	1	117	0: Anamorphic; 1: Virtual Wide; 2: Letterbox; 3: Native; 4: 4:3 Output; 5: User define	Program Scale Aspect Ratio
0	1	118	0: Left + Up; 1: Right + Up; 2: Center; 3: Left + Down; 4: Right + Down	Program Scale Native Location
0	1	119	-32 ~ 32	Program Scale Aspect RatioHorZoom
0	1	120	-32 ~ 32	Program Scale Aspect RatioVerZoom
0	1	121	-32 ~ 32	Program Scale Aspect RatioHorPan
0	1	122	-32 ~ 32	Program Scale Aspect RatioVerPan
0	1	123	0: Off; 1: On	Program PIP On/Off
0	1	124	0: Channel 1; 1: Channel 2; 2: Channel 3; 3: Channel 4; 4: Channel 5; 5: Channel 6; 6: Channel 7; 7: Channel 8	Program PIP Source
0	1	125	0: 1/25; 1: 1/16; 2: 1/9; 3: 1/4; 4: Split; 5: Custom	Program PIP Size
0	1	126	1 ~ 255	Program PIP H-Size
0	1	127	1 ~ 255	Program PIP V-Size
0	1	128	-32 ~ 32	Program PIP H-Position
0	1	129	-32 ~ 32	Program PIP V-Position
0	1	130	0: 640x480; 1: 800x600; 2: 832x624; 3: 852x480; 4: 1024x768; 5: 1280x720; 6: 1280x768; 7: 1280x1024; 8: 1366x768; 9: 1365x1024; 10: 1400x1050; 11: 1600x1200; 12: 480p; 13: 576p; 14: 720p; 15: 1080i; 16: 1080p; 17: User define	Program Output Resolution
0	1	131	0: 50; 1: 60; 2: 75	Program Output RefreshRate

¹ Param 2 = 0 ~ 999

VP-727xl Communication Protocol

Control Type		F	Param1	Function Description
Set	Get			
0	1	132	0: Off; 1: 32 Gray Ramp; 2: Sharpness; 3: Red; 4: Green; 5: Blue; 6: White; 7: Black; 8: Chessboard; 9: Color Bar; 10: Aspect Ratio; 11: RGB Gray Steps; 12: Gamma Check	Program Output Test Pattern
0	1	133	1 ~ 4095	Program Output User Mode HT
0	1	134	1 ~ 511	Program Output User Mode HW
0	1	135	1 ~ 511	Program Output User Mode HS
0	1	136	1 ~ 2047	Program Output User Mode HA
0	1	137	0: -; 1: +	Program Output User Mode HP
0	1	138	1 ~ 4095	Program Output User Mode VT
0	1	139	1 ~ 31	Program Output User Mode VW
0	1	140	1 ~ 127	Program Output User Mode VS
0	1	141	1 ~ 2047	Program Output User Mode VA
0	1	142	0: -; 1: +	Program Output User Mode VP
0	1	143	6 ~ 200	Program Output User Mode OCLK
0	1	144	0 ~ 255	Program Output User Mode Delay
0	-	145	-	Program Output User Mode SetCurrent
0	1	146	0: Cut; 1: Fade; 2: Diagonal; 3: Wipe; 4: Circle; 5: Square; 6: Corner; 7: Chessboard	Transition Effect
0	1	147	1 ~ 5	Transition Speed
0	1	148	0: Top left; 1: Bottom left; 2: Top right; 3: Bottom right	Transition Diagonal Option
0	1	149	0: Left to right; 1: Right to left; 2: Up; 3: Down	Transition Wipe Option
0	1	150	0: In; 1: Out	Transition Circle Option
0	1	151	0: In; 1: Out	Transition Square Option
0	1	152	0: Top left; 1: Bottom left; 2: Top right; 3: Bottom right	Transition Corner Option
0	1	153	0: In; 1: Out	Transition Chessboard Option
0	-	154	-	Transition Take
0	1	155	0: Off; 1: On	TCPIP DHCP
0	1	156 ²	0 ~ 255	TCPIP IP Address
0	1	157 ²	0 ~ 255	TCPIP Subnet Mask
0	1	158 ²	0 ~ 255	TCPIP Gateway
0	-	159	-	TCPIP Apply
0	1	160	0: Normal; 1: Double	OSD Setting Size
0	1	161	-32 ~ 32	OSD Setting HorPosition
0	1	162	-32 ~ 32	OSD Setting VerPosition
0	1	163	3 ~ 60	OSD Setting TimeOut
0	1	164	0: Off; 1: On	Misc Logo
0	1	165	0: Off; 1: On	Misc SaveLock
0	1	166	0: Off; 1: On	Misc InputLock
0	-	167	-	Save Setting 1
0	-	168	-	Save Setting 2
0	-	169	-	Save Setting 3
0	-	170	-	Save Setting 4
0	-	171	-	Save Setting 5
0	-	172	-	Save Setting 6
0	-	173	-	Save Setting 7
0	-	174	-	Save Setting 8
0	-	175	-	Recall Setting 1
0	-	176	-	Recall Setting 2
0	-	177	-	Recall Setting 3
0	-	178	-	Recall Setting 4
0	-	179	-	Recall Setting 5

¹ Param 2 = 0 ~ 999

² Param 2 = 0 ~ 255, Param 3 = 0 ~ 255, and Param 4 = 0 ~ 255

VP-727xl Communication Protocol

Control Type		F	Param1	Function Description
Set	Get			
0	-	180	-	Recall Setting 6
0	-	181	-	Recall Setting 7
0	-	182	-	Recall Setting 8
0	1	183	0: Cancel; 1: Ok	Factory Reset
-	1	184	-	Preview Main Standard
-	1	185	-	Preview PIP Type
-	1	186	-	Preview PIP Standard
-	1	187	-	Program Main Standard
-	1	188	-	Program PIP Type
-	1	189	-	Program PIP Standard
0	1	195	0: Off; 1: On	Preview Freeze
0	1	196	0: Off; 1: On	Preview Blank
0	1	197	0: Off; 1: On	Program Freeze
0	1	198	0: Off; 1: On	Program Blank
0	1	199	0: Off; 1: On	Panel Lock
0	1	200	0: Off; 1: On	OSD
0	1	201	0: Off; 1: On	Power
-	1	202	0: Off; 1: On	Take
0	-	203	-	Erase Setting 1
0	-	204	-	Erase Setting 2
0	-	205	-	Erase Setting 3
0	-	206	-	Erase Setting 4
0	-	207	-	Erase Setting 5
0	-	208	-	Erase Setting 6
0	-	209	-	Erase Setting 7
0	-	210	-	Erase Setting 8
0	-	211	-	Erase All

Control Type		F	Param1	Param2	Param3	Function Description
Set	Get					
	1	212	0~3267 1->ON, 0->OFF bit 0: Chessboard bit 1: Panel lock bit 2: Menu bit 3: Enter bit 4: Left bit 5: Up bit 6: Down bit 7: Right bit 8: OSD	0~32767 1->ON, 0->OFF bit 0: Program Channel 8 bit 1: Preview Freeze bit 2: Program Freeze bit 3: Preview Blank bit 4: Program Blank bit 5: Preview PIP bit 6: Program PIP bit 7: Take bit 8: Cut bit 9: Diagonal bit 10: Circle bit 11: Corner bit 12: Fade bit 13: Wipe bit 14: Square	0~32767 1-> ON, 0->OFF bit 0: Preview Channel 1 bit 1: Program Channel 1 bit 2: Preview Channel 2 bit 3: Program Channel 2 bit 4: Preview Channel 3 bit 5: Program Channel 3 bit 6: Preview Channel 4 bit 7: Program Channel 4 bit 8: Preview Channel 5 bit 9: Program Channel 5 bit 10: Preview Channel 6 bit 11: Program Channel 6 bit 12: Preview Channel 7 bit 13: Program Channel 7 bit 14: Preview Channel 8	Keypad LED status
0	1	213	0: Swap 1: Follow			Take Mode
0	1	214	0: Black 1: Blue			Background
0	1	215	0: Black 1: Blue			Blank Color
0	1	216	0: Off 1: On			

VP-727xl Communication Protocol

Control Set	Type Get	F	Param1	Param2	Param3	Function Description
0	1	217	0: User 1 1: User 2 2: User 3			
0	1	218	0: User 1 1: User 2 2: User 3			
0	1	219	0 = no damping 1 = minimum damping 2 = low damping 3 = medium (factory default) 4 = maximum damping			
0	1	220	16~240			
0	1	221	0: Dynamic 1: Static	-	-	Preview De-Interlace mode selection * only affects HDMI / HD Comp input for interlace mode
0	1	222	0: Dynamic 1: Static	-	-	Program De-Interlace mode selection * only affects HDMI / HD Comp input for interlace mode
0	1	223	0: Channel 1 1: Channel 2 2: Channel 3 3: Channel 4 4: Channel 5 5: Channel 6 6: Channel 7 7: Channel 8	-	-	Audio Preview input source
0	1	224	0: Channel 1 1: Channel 2 2: Channel 3 3: Channel 4 4: Channel 5 5: Channel 6 6: Channel 7 7: Channel 8	-	-	Audio Program input source
0	1	225	0: Preview 1: Program	-	-	Audio headphone source
0	1	226	0: Audio Follow Video 1: Audio Breakaway	-	-	Audio Follow Video or Audio Breakaway
0	1	227	0: Off 1: On	-	-	Audio Fade
0	1	228	0 ~ 127	-	-	Audio Preview Input Volume, 0 = Mute
0	1	229	0 ~ 127	-	-	Audio Preview Output Volume, 0 = Mute
0	1	230	0 ~ 127	-	-	Audio Program Input Volume, 0 = Mute
0	1	231	0 ~ 31	-	-	Audio Program Output Volume, 0 = Mute
0	1	232	0 ~ 16	-	-	Audio Headphone Volume, 0 = Mute

VP-727xl Communication Protocol

Control Type		F	Param1	Param2	Param3	Function Description
Set	Get					
0	1	233	0 ~ 12	-	-	Audio Bass
0	1	234	0 ~ 12	-	-	Audio Treble 0
0	1	235	0 ~ 20	-	-	Audio Balance
0	1	236	0 ~ 127	-	-	Audio Program Input Delay
0	-	237	-	-	-	Audio TAKE

12 VP-727xl Text Overlay Protocol

Table 18 includes the Text Overlay Protocol.

Each command includes three parameters: P1, P2 and P3.

Table 18: Text Overlay Protocol of the VP-727xl

	Functions	Command	P1	P2	P3	Comments
1	Display Buffer Configuration	T12ED ** **	Page No. of Buffer	Page Width	Page Height	No of page <= 7 Buffer size limitation: Width * Height * (Page No+1) <= 70KB
2	V-Position	T13EC **	Vertical Location	NA	NA	1~2047
3	H-Position	T14EB **	Horizontal Location	NA	NA	1~2047, Non Used
4	Text Color Effect	T16E9 **	Mode	NA	NA	Mode: 0: Transparency 1: Partial Transparency 2: Normal
5	Text RGB Color	T17E8 ** **	R	G	B	RGB color 0-255
6	Text Partial Transparency Color	T18E7 ** **	R	G	B	RGB color 0-255
7	Background Color Effect	T19E6 **	Mode	NA	NA	0: Transparency 1: Partial Transparency 2: Normal
8	Background RGB Color	T1AE5 ** **	R	G	B	RGB color 0-255
9	Background Partial Transparency Color	T1BE4 ** **	R	G	B	RGB color 0-255
10	TextOverlay On	T1CE3	NA	NA	NA	Enable TextOverlay
11	TextOverlay Off	T1DE2	NA	NA	NA	Disable TextOverlay
12	Blank Time	T1EE1 **	Seconds	NA	NA	Time between Two Strings, 0-30Sec
13	Text Bitmap Download Start	T1FE0	NA	NA	NA	PC start to send bit string
14	TextOverlay Mode	T20DF **	Mode	NA	NA	0: Scroll 1: Static
15	Text H-Shift (only available for static mode)	T21DE ** **	Page	H location	NA	Text placement on H location Page: Which string active H location < 32767
16	Speed	T22DD ** **	Refresh rate	Step Size	NA	Refresh rate: 10-100ms (Slow – fast) Step Size: 1-10 pixels

- Command handshake: Only leading character for command start and no ending code.
- Bit map file format: It is a raster scan image with 1 bit. 0 for background and 1 for text. The 0, 1 is ASCII code.
T1FE0001100010010010010011110010010; send bitmap as following image

LIMITED WARRANTY

Kramer Electronics (hereafter *Kramer*) warrants this product free from defects in material and workmanship under the following terms.

HOW LONG IS THE WARRANTY

Labor and parts are warranted for seven years from the date of the first customer purchase.

WHO IS PROTECTED?

Only the first purchase customer may enforce this warranty.

WHAT IS COVERED AND WHAT IS NOT COVERED

Except as below, this warranty covers all defects in material or workmanship in this product. The following are not covered by the warranty:

1. Any product which is not distributed by Kramer, or which is not purchased from an authorized Kramer dealer. If you are uncertain as to whether a dealer is authorized, please contact Kramer at one of the agents listed in the Web site www.kramerelectronics.com.
2. Any product, on which the serial number has been defaced, modified or removed.
3. Damage, deterioration or malfunction resulting from:
 - i) Accident, misuse, abuse, neglect, fire, water, lightning or other acts of nature
 - ii) Product modification, or failure to follow instructions supplied with the product
 - iii) Repair or attempted repair by anyone not authorized by Kramer
 - iv) Any shipment of the product (claims must be presented to the carrier)
 - v) Removal or installation of the product
 - vi) Any other cause, which does not relate to a product defect
 - vii) Cartons, equipment enclosures, cables or accessories used in conjunction with the product

WHAT WE WILL PAY FOR AND WHAT WE WILL NOT PAY FOR

We will pay labor and material expenses for covered items. We will not pay for the following:

1. Removal or installations charges.
2. Costs of initial technical adjustments (set-up), including adjustment of user controls or programming. These costs are the responsibility of the Kramer dealer from whom the product was purchased.
3. Shipping charges.

HOW YOU CAN GET WARRANTY SERVICE

1. To obtain service on you product, you must take or ship it prepaid to any authorized Kramer service center.
2. Whenever warranty service is required, the original dated invoice (or a copy) must be presented as proof of warranty coverage, and should be included in any shipment of the product. Please also include in any mailing a contact name, company, address, and a description of the problem(s).
3. For the name of the nearest Kramer authorized service center, consult your authorized dealer.

LIMITATION OF IMPLIED WARRANTIES

All implied warranties, including warranties of merchantability and fitness for a particular purpose, are limited in duration to the length of this warranty.

EXCLUSION OF DAMAGES

The liability of Kramer for any effective products is limited to the repair or replacement of the product at our option. Kramer shall not be liable for:

1. Damage to other property caused by defects in this product, damages based upon inconvenience, loss of use of the product, loss of time, commercial loss; or:
2. Any other damages, whether incidental, consequential or otherwise. Some countries may not allow limitations on how long an implied warranty lasts and/or do not allow the exclusion or limitation of incidental or consequential damages, so the above limitations and exclusions may not apply to you.

This warranty gives you specific legal rights, and you may also have other rights, which vary from place to place.

NOTE: All products returned to Kramer for service must have prior approval. This may be obtained from your dealer.

This equipment has been tested to determine compliance with the requirements of:

EN-50081:	"Electromagnetic compatibility (EMC); generic emission standard. Part 1: Residential, commercial and light industry"
EN-50082:	"Electromagnetic compatibility (EMC) generic immunity standard. Part 1: Residential, commercial and light industry environment".
CFR-47:	FCC Rules and Regulations: Part 15: "Radio frequency devices Subpart B Unintentional radiators"

CAUTION!

- Servicing the machines can only be done by an authorized Kramer technician. Any user who makes changes or modifications to the unit without the expressed approval of the manufacturer will void user authority to operate the equipment.
- Use the supplied DC power supply to feed power to the machine.
- Please use recommended interconnection cables to connect the machine to other components.



For the latest information on our products and a list of Kramer distributors, visit our Web site: www.kramerelectronics.com, where updates to this user manual may be found. We welcome your questions, comments and feedback.



Caution

Safety Warning:

Disconnect the unit from the power supply before opening/servicing.



Kramer Electronics, Ltd.

Web site: www.kramerelectronics.com

E-mail: info@kramerel.com

P/N: 2900-000334 REV 1