

**Exploded View:
Wall Arm Assembly**

Attachment hardware for wood stud walls provided. For attachment to concrete, concrete block or brick order accessory kit #ACC200.
Hardware for concrete attachment may be included with the product by special order.

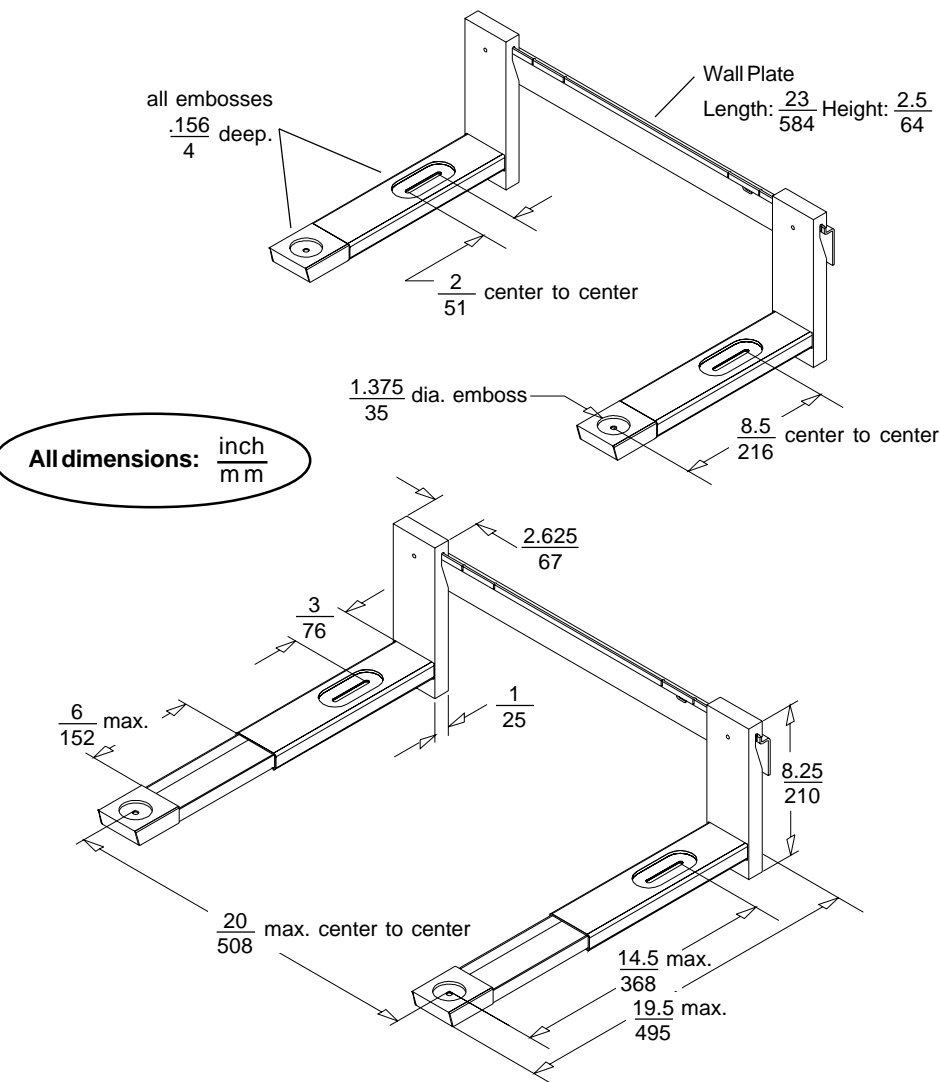
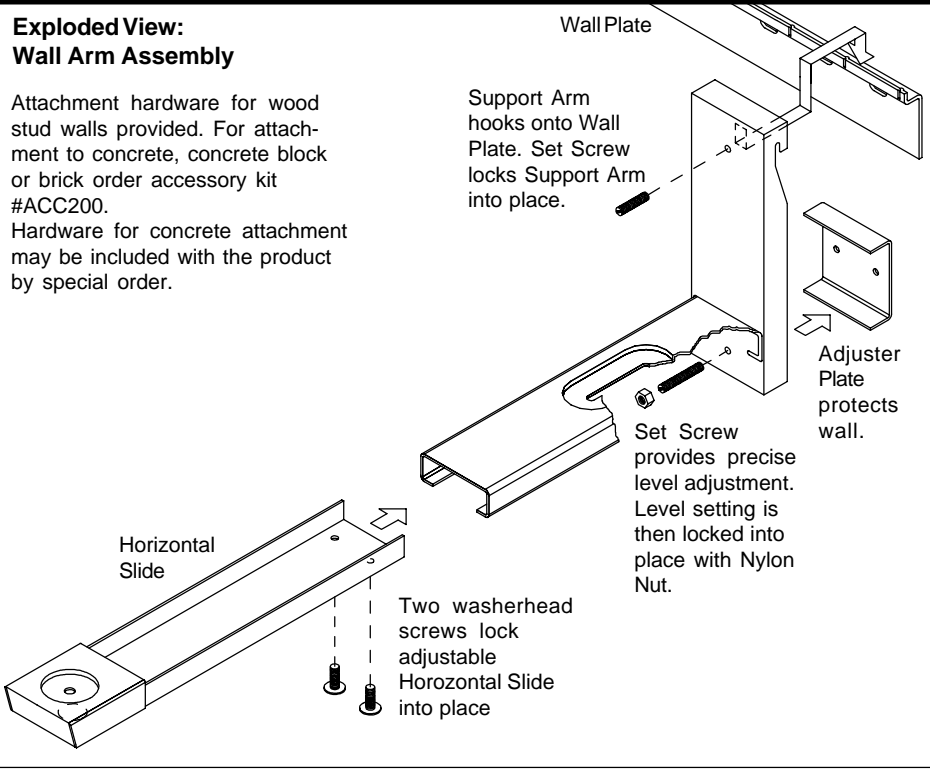

MODEL #	WEIGHT	SHIPPING WEIGHT	MAX. LOAD CAPACITY
DS600, DS600W	8 LBS. (3.6 KG.)	9 LBS. (4 KG.)	100 LBS. (45 KG.)

Shipping weight based on single unit shipment. Per unit shipping weight may be less for bulk orders.

Architects specifications: The wall bracket shall be a Multi-Mount™ model _____. It shall be used to support home electronics or small appliances (microwave oven, stereo component(s), P.C.) with a weight of no more than 100 lbs. (45 kg.). The wall bracket shall have adjustable width and depth as well as a feature for level adjustment. Assembly and installation shall be made in accordance with instructions provided by the manufacturer. Finish shall be black or white fused epoxy. The kit shall contain all necessary hardware for assembly and installation to a wood stud wall. An additional fastener package shall be available to enable installation to solid concrete and concrete block walls.

**TECHNICAL DATA SHEET
MULTI-MOUNT™**



Peerless Industries, Inc.
1980 Hawthorne Ave.
Melrose Park, IL 60160

phone: (708) 865-8870
fax: (708) 865-2941