

---

## S P E C F I L E

---

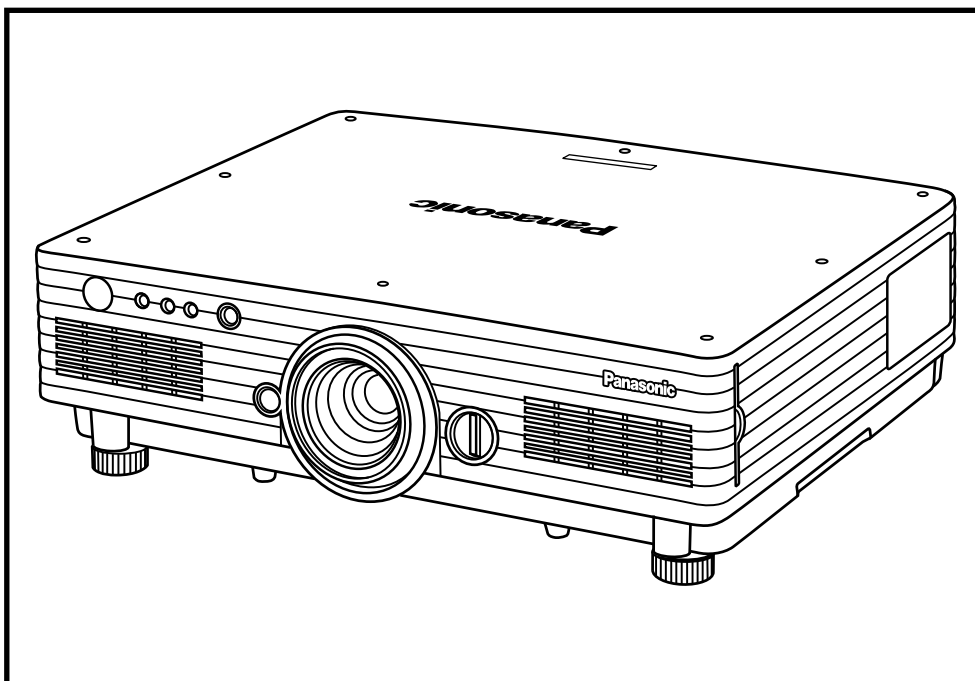

Product Number : **PT-D4000**  
Product Name : DLP™ Projectors

**Specifications**

**Main Unit**

Power supply:	North America:	120 V AC, 50/60 Hz
	Europe:	220–240 V AC, 50/60 Hz
Power consumption:	North America:	540 W (540 VA) (10 W during standby mode with fan stopped)
	Europe:	520 W (570 VA) (15 W during standby mode with fan stopped)
DLP™ chip:	Panel size:	0.7" diagonal (4:3 aspect ratio)
	Display method:	DLP™ chip x 1, DLP™ system
	Pixels:	786,432 (1,024 x 768) x 1, total of 786,432 pixels
Lens:		Powered zoom/focus lenses (4:3 aspect ratio: 1.8–2.4:1), F 1.7–2.0, f 25.6–33.8 mm
Lamp:		210 W UHM™ lamps (x 2) (dual lamp system)
Screen size:		50–600 inches (50–200 inches with the ET-DLE050), 4:3 aspect ratio
Brightness*1:		4,000 lumens (dual lamp, high power mode)
Center-to-corner uniformity*1:		90%
Contrast*1:		1,600:1 (full on/full off, contrast mode: high, brightness: 2,000 lumens) 800:1 (full on/full off, contrast mode: normal)
Resolution:		1,024 x 768 pixels (1,600 x 1,200 pixels compatible, compression mode)
Scanning frequency:	RGB:	Horizontal: 15–91 kHz, Vertical: 50–85 Hz, Dot clock: 150 MHz or lower
	YPbPr (YCbCr):	480i: fh 15.75 kHz; fv 59.94 Hz, 576i: fh 15.63 kHz; fv 50 Hz, 480p: fh 31.50 kHz; fv 59.94 Hz, 576p: fh 31.25 kHz; fv 50 Hz, 720/60p: fh 45 kHz; fv 60 Hz, 720/50p: fh 37.5 kHz; fv 50 Hz, 1035/60i: fh 33.75 kHz; fv 60 Hz, 1080/60i: fh 33.75 kHz; fv 60 Hz, 1080/50i: fh 28.13 kHz; fv 50 Hz, 1080/60p: fh 67.5 kHz; fv 60 Hz, 1080/50p: fh 56.25 kHz; fv 50 Hz
	S-Video/Video:	Horizontal: 15.75/15.63 kHz, Vertical: 50/60 Hz, (NTSC, NTSC4.43, PAL, PAL60, PAL-N, PAL-M, SECAM)
Optical axis shift:		Horizontal (manual) and vertical (powered), Horizontal: ±10%, vertical: +50%
Keystone correction range:		Vertical: ±30°
Installation:		Ceiling/floor, front/rear
Terminals*2:	DVI-D IN:	DVI-D 24-pin x 1, DVI 1.0 compliant, HDCP compatible, for single link only 480p, 576p, 1080/60i, 1080/50i, 1080/60p, 1080/50p, 720/60p, 720/50p, VGA60, SVGA60, XGA50, XGA60, XGA70, XGA75, XGA85, SXGA50, SXGA60, SXGA+60, WXGA768/50, WXGA768/60
	RGB 1 IN:	BNC x 5
	R, G, B:	G: 0.7 Vp-p (G: 1.0 Vp-p for sync on G), 75Ω, B, R: 0.7 Vp-p, 75Ω HD/VD, SYNC: TTL (positive/negative)
	Y, Pb, Pr:	Y: 1.0 p-p, 75Ω (including sync signal), Pb/Pr: 0.7 Vp-p, 75Ω
	RGB 2 IN:	D-sub HD 15-pin x 1
	R, G, B:	G: 0.7 Vp-p (G: 1.0 Vp-p for sync on G), 75Ω, B, R: 0.7 Vp-p, 75Ω HD/VD, SYNC: TTL (positive/negative)
	Y, Pb, Pr:	Y: 1.0 p-p, 75Ω (including sync signal), Pb/Pr: 0.7 Vp-p, 75Ω
	VIDEO IN:	BNC x 1, 1.0 Vp-p, 75Ω
	S-VIDEO IN:	Mini DIN 4-pin x 1, Y: 1.0 Vp-p, C: 0.286 Vp-p, 75Ω
	SERIAL IN:	D-sub 9-pin x 1 (RS-232C compliant) for external controller
	SERIAL OUT:	D-sub 9-pin x 1 (RS-232C compliant) for external controller
	REMOTE 1 IN:	M3 jack x 1 for wired remote control or link control
	REMOTE 1 OUT:	M3 jack x 1 for link control
	REMOTE 2 IN:	D-sub 9-pin x 1 for external control (parallel)
	LAN:	RJ-45 x 1, compliant with PLink™, 10Base-T/100Base-TX
Power cord length:		3.0 m (9'10")
Cabinet materials:		Molded plastic
On-screen menu:		9 languages: English, French, German, Spanish, Italian, Russian, Korean, Chinese, and Japanese

DLP™ Projectors

Dimensions (W x H x D): 530 x 167 x 441 mm (20-7/8" x 6-9/16" x 17-3/8")  
 Weight: 13.7 kg (30.2 lbs) (with supplied lens)  
 Operating temperature: 0°-45°C (32°-113°F)  
 Operating humidity: 20%-80% (no condensation)

**Remote Control Unit**

Power supply: 3 V DC (AA battery x 2)  
 Operation range\*3: Wireless: Approx. 30 m (98.4 feet) when operated from directly in front of the signal receptor  
 Dimensions (W x H x D): 51 x 176 x 22.5 mm (2" x 6-15/16" x 7/8")  
 Weight: 134 g (4.7 oz) (including batteries)

**Supplied Accessories**

Power cord, Wireless/wired remote control unit, Batteries for remote control (x 2), Wire rope

**Optional Accessories**

Replacement lamp unit: ET-LAD40 (1 unit)  
 ET-LAD40W (set of two lamps)  
 Ceiling mount bracket: ET-PKD56H (for high ceilings)  
 ET-PKD55S (for low ceilings)  
 Zoom lens (1.3-1.8:1) ET-DLE100  
 Zoom lens (2.4-4.0:1) ET-DLE200  
 Zoom lens (3.8-6.0:1) ET-DLE300  
 Zoom lens (5.8-8.1:1) ET-DLE400  
 Fixed-focus lens (0.8:1) ET-DLE050

Weights and dimensions shown are approximate. Specifications subject to change without notice.  
 \*1 Values indicate overall average values of the product at the time of shipment and are stated based on JIS X 6911:2003 Data Projector Specification Sheet Format. Measurement method and conditions are based on Appendix 2.  
 \*2 The HD/SYNC and VD inputs do not accept the tri-level sync signal.  
 \*3 Operation range differs depending on environments.

**Dimensions**

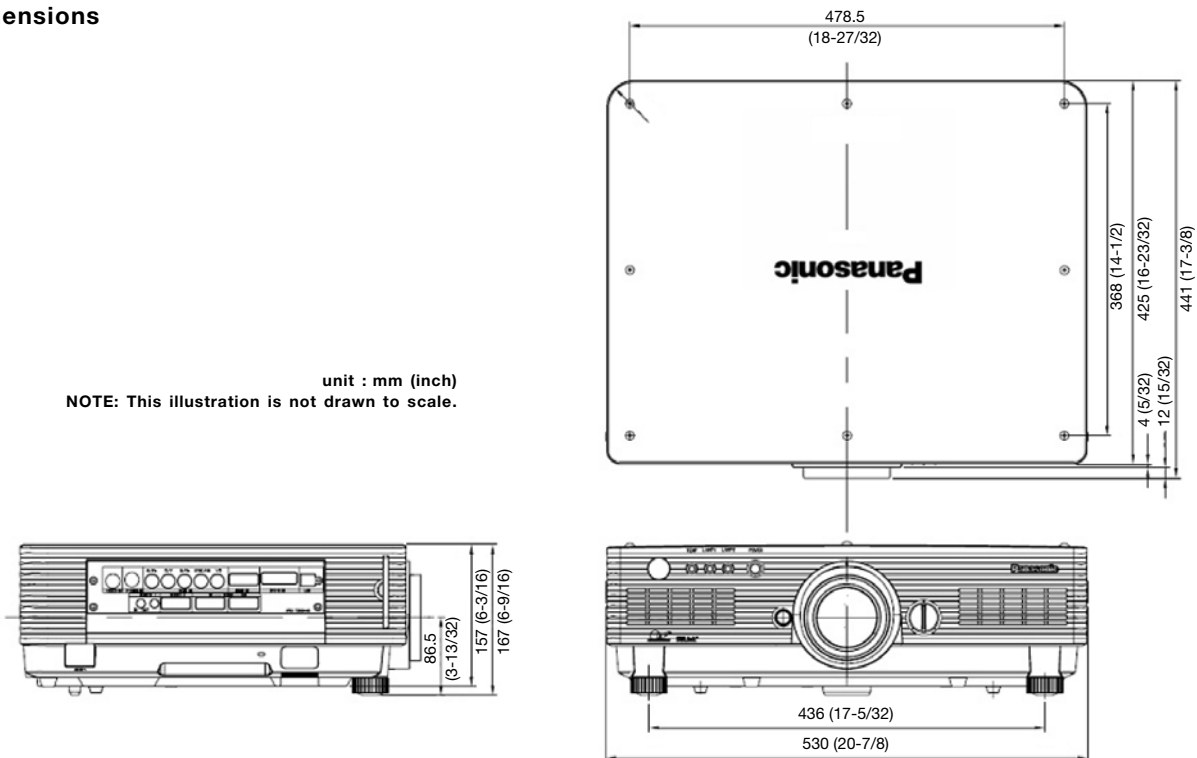

**Terminals**

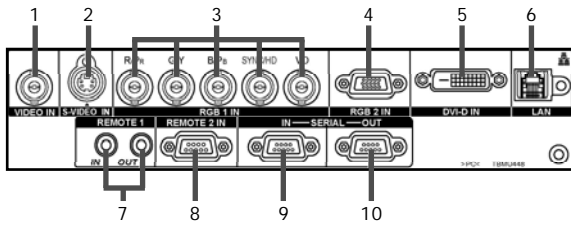

- 1 Video input
- 2 S-Video input
- 3 RGB 1 input
- 4 RGB 2 Input
- 5 DVI-D input
- 6 LAN connector
- 7 Remote 1 input and output
- 8 Remote 2 input
- 9 Serial input
- 10 Serial output

**RGB IN connector pin assignment**

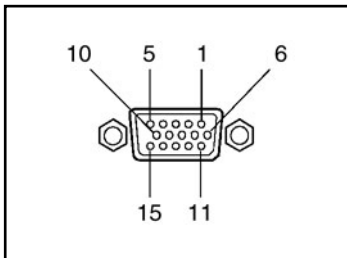

no.	signal	no.	signal	no.	signal
1	R/PR	6	GND	11	GND
2	G/Y	7	GND	12	NC
3	B/PB	8	GND	13	HD/SYNC
4	GND	9	NC	14	VD
5	GND	10	GND	15	NC

**DVI-D output connector pin assignment**

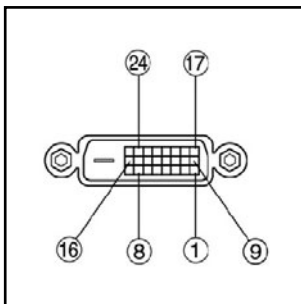

no.	signal	no.	signal	no.	signal
1	T, M, D, S data 2-	9	T, M, D, S data 1-	17	T, M, D, S data 0-
2	T, M, D, S data 2+	10	T, M, D, S data 1+	18	T, M, D, S data 0+
3	T, M, D, S data 2 shield	11	T, M, D, S data 1 shield	19	T, M, D, S data 0 shield
4	NC	12	NC	20	NC
5	NC	13	NC	21	NC
6	DDC clock	14	+5 V	22	T, M, D, S clock shield
7	DDC clock	15	GND	23	T, M, D, S clock +
8	NC	16	Hot plug detection	24	T, M, D, S clock -

Standard setting-up position (when installed using the ET-PKD56H)

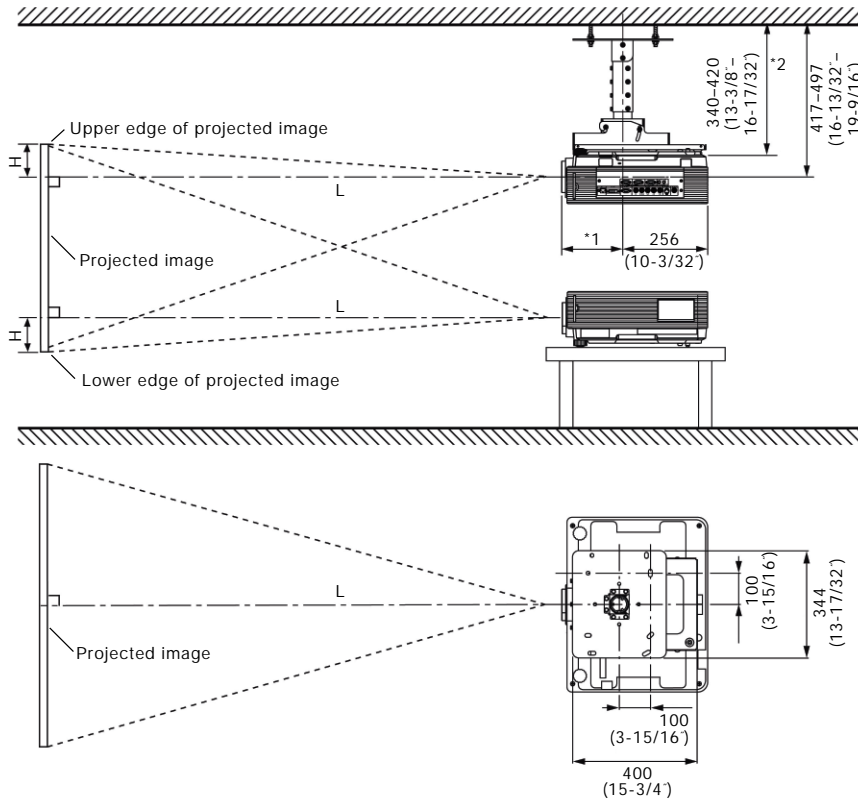

\*3 When the lens protrudes to the maximum.  
 185 mm (7-9/32) with the supplied lens  
 177 mm (6-31/32) with the ET-DLE050  
 209 mm (8-7/32) with the ET-DLE100  
 208 mm (8-3/16) with the ET-DLE200  
 196 mm (7-23/32) with the ET-DLE300  
 196 mm (7-23/32) with the ET-DLE400

\*4 Adjustable in 40 mm (1-9/16) steps.

unit : mm (inch)

Standard setting-up position (when installed using the ET-PKD55S)

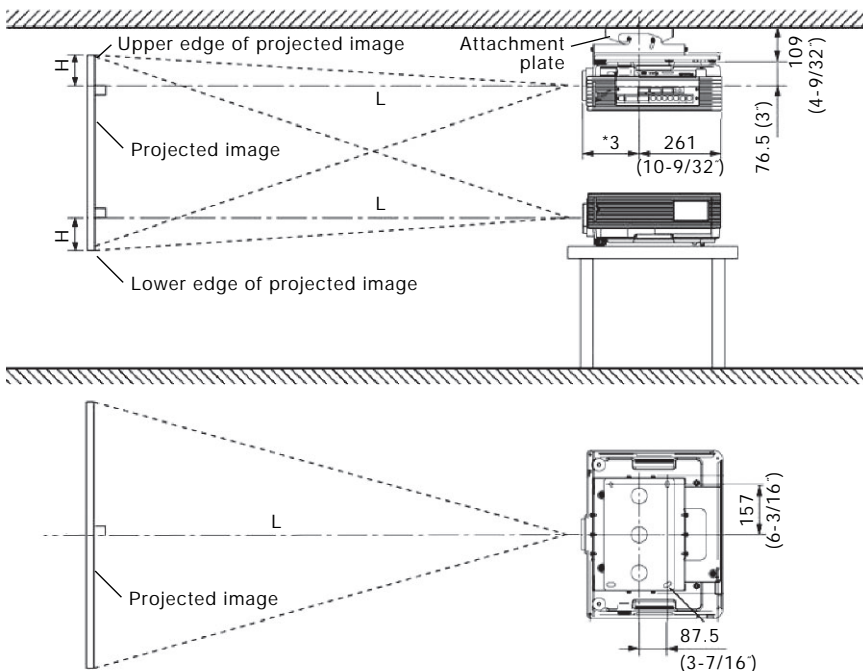

\*3 When the lens protrudes to the maximum.  
 180 mm (7-3/32) with the supplied lens  
 172 mm (6-25/32) with the ET-DLE050  
 204 mm (8-1/32) with the ET-DLE100  
 203 mm (8) with the ET-DLE200  
 191 mm (7-17/32) with the ET-DLE300  
 191 mm (7-17/32) with the ET-DLE400

unit : mm (inch)

NOTE:  
 Illustrations show the projector installed using optional ceiling bracket.  
 This illustration is not drawn to scale.  
 Values shown are approximate.  
 The value for L (distance to screen) varies slightly depending on the zoom lens characteristics. When the shortest projection distance (min.) is used, a small amount of distortion may occur in the image due to the zoom lens characteristics.

**CAUTION**  
 The ET-DLE050 has a fixed short-focus lens. Therefore, the lens shift function provided in the main unit cannot be used.  
 If the lens shift function is used, the corners of images may not be displayed or images may remain out of focus in some cases.

**Projection distance for 4:3 aspect ratio screen  
(meters)**

Screen size (inch, diagonal)	Distance to screen (L)										Height from the edge of screen to center of lens (H)		
	Zoom										Fixed-focus	Zoom lenses	Fixed-focus lens
	ET-DLE100 Zoom lens		Supplied lens		ET-DLE200 Zoom lens		ET-DLE300 Zoom lens		ET-DLE400 Zoom lens		ET-DLE050 Fixed-focus lens		
min.	max.	min.	max.	min.	max.	min.	max.	min.	max.				
50	1.4	1.8	1.9	2.4	2.5	4.0	3.9	6.0	6.0	8.2	0.794	0 – 0.38	0.381
60	1.7	2.1	2.2	2.8	3.0	4.8	4.7	7.2	7.1	9.9	0.960	0 – 0.46	0.457
70	1.9	2.5	2.6	3.3	3.5	5.6	5.5	8.4	8.3	11.5	1.126	0 – 0.53	0.533
80	2.2	2.9	3.0	3.8	4.0	6.5	6.3	9.7	9.5	13.2	1.292	0 – 0.61	0.610
90	2.5	3.3	3.3	4.3	4.5	7.3	7.1	10.9	10.7	14.8	1.458	0 – 0.69	0.686
100	2.8	3.6	3.7	4.8	5.0	8.1	7.9	12.1	11.8	16.5	1.624	0 – 0.76	0.762
120	3.3	4.4	4.5	5.8	6.0	9.8	9.5	14.6	14.2	19.8	1.956	0 – 0.91	0.914
150	4.1	5.5	5.6	7.3	7.5	12.2	11.8	18.3	17.7	24.7	2.454	0 – 1.14	1.143
200	5.5	7.3	7.4	9.7	10.1	16.4	15.8	24.5	23.6	32.9	3.284	0 – 1.52	1.524
250	6.9	9.2	9.3	12.2	12.6	20.5	19.8	30.6	29.5	41.2	–	0 – 1.91	–
300	8.3	11.1	11.1	14.6	15.1	24.6	23.8	36.8	35.4	49.4	–	0 – 2.29	–
400	11.0	14.8	14.8	19.5	20.1	32.8	31.7	49.1	47.1	65.9	–	0 – 3.05	–
500	13.8	18.5	18.5	24.4	25.2	41.1	39.7	61.4	58.9	82.3	–	0 – 3.81	–
600	16.6	22.2	22.3	29.3	30.2	49.3	47.6	73.7	70.6	98.8	–	0 – 4.57	–

**Projection distance for 4:3 aspect ratio screen  
(feet)**

Screen size (inch, diagonal)	Distance to screen (L)										Height from the edge of screen to center of lens (H)		
	Zoom										Fixed-focus	Zoom lenses	Fixed-focus lens
	ET-DLE100 Zoom lens		Supplied lens		ET-DLE200 Zoom lens		ET-DLE300 Zoom lens		ET-DLE400 Zoom lens		ET-DLE050 Fixed-focus lens		
min.	max.	min.	max.	min.	max.	min.	max.	min.	max.				
50	4.4	5.9	6.0	7.8	8.1	13.2	12.6	19.7	19.4	27.2	2.605	0 – 1.25	1.250
60	5.3	7.1	7.2	9.4	9.8	15.9	15.2	23.8	23.3	32.6	3.149	0 – 1.50	1.500
70	6.2	8.3	8.4	11.0	11.4	18.6	17.9	27.8	27.1	38.0	3.694	0 – 1.75	1.750
80	7.1	9.6	9.6	12.6	13.1	21.3	20.5	31.9	31.0	43.4	4.239	0 – 2.00	2.000
90	8.1	10.8	10.8	14.3	14.7	24.0	23.1	35.9	34.9	48.8	4.783	0 – 2.25	2.250
100	9.0	12.0	12.1	15.9	16.4	26.7	25.7	39.9	38.7	54.2	5.328	0 – 2.50	2.500
120	10.8	14.4	14.5	19.1	19.7	32.1	30.9	48.0	46.4	65.0	6.417	0 – 3.00	3.000
150	13.5	18.1	18.1	23.9	24.6	40.3	38.7	60.2	58.0	81.2	8.051	0 – 3.75	3.750
200	18.0	24.2	24.2	31.9	32.9	53.8	51.8	80.4	77.3	108.2	10.774	0 – 5.00	5.000
250	22.5	30.3	30.3	40.0	41.2	67.3	64.8	100.6	96.6	135.2	–	0 – 6.25	–
300	27.1	36.4	36.4	48.0	49.4	80.8	77.8	120.8	115.9	162.2	–	0 – 7.50	–
400	36.1	48.6	48.6	64.1	66.0	107.8	103.9	161.2	154.5	216.2	–	0 – 10.00	–
500	45.2	60.8	60.7	80.2	82.5	134.9	130.0	201.6	193.0	270.2	–	0 – 12.50	–
600	54.2	73.0	72.9	96.2	99.0	161.9	156.1	242.0	231.6	324.2	–	0 – 15.00	–

- The value for L (distance to screen) varies slightly depending on the zoom lens characteristics.
- At the shortest projection distance, the zoom lens characteristics may cause slight image distortion.
- When vertical keystone correction is used, the image is corrected in the direction that reduces its projected size.
- For the ET-DLE050, the height from the edge of the screen to the center of the lens (H) is 1/2 of the screen height.
- The brightness varies depending on the zoom settings.

**Calculation of the projection distance**

For a screen size different from the above, use the equation below to calculate the projection distance.

Aspect ratio 4:3

ET-DLE100	minimum	$L (m) = (\text{diagonal screen size in inches}) \times 0.0276 - 0.0452$
	maximum	$L (m) = (\text{diagonal screen size in inches}) \times 0.0372 - 0.0478$
Supplied lens	minimum	$L (m) = (\text{diagonal screen size in inches}) \times 0.0371 - 0.0507$
	maximum	$L (m) = (\text{diagonal screen size in inches}) \times 0.0490 - 0.0500$
ET-DLE200	minimum	$L (m) = (\text{diagonal screen size in inches}) \times 0.0504 - 0.0657$
	maximum	$L (m) = (\text{diagonal screen size in inches}) \times 0.0824 - 0.0758$
ET-DLE300	minimum	$L (m) = (\text{diagonal screen size in inches}) \times 0.0795 - 0.1380$
	maximum	$L (m) = (\text{diagonal screen size in inches}) \times 0.1232 - 0.1310$
ET-DLE400	minimum	$L (m) = (\text{diagonal screen size in inches}) \times 0.1176 + 0.0244$
	maximum	$L (m) = (\text{diagonal screen size in inches}) \times 0.1646 + 0.0651$
ET-DLE050	(fixed focus)	$L (m) = (\text{diagonal screen size in inches}) \times 0.0166 - 0.0361$

- Distances calculated with the above equations will include a slight error.
- When an SXGA signal is input, the left and right edges of the image are blanked, and the image is projected at a screen aspect ratio of 5:4.
- The brightness varies depending on the zoom setting.

**Shift range**

Optical axis shift function allows to shift the position of a projected image as shown.

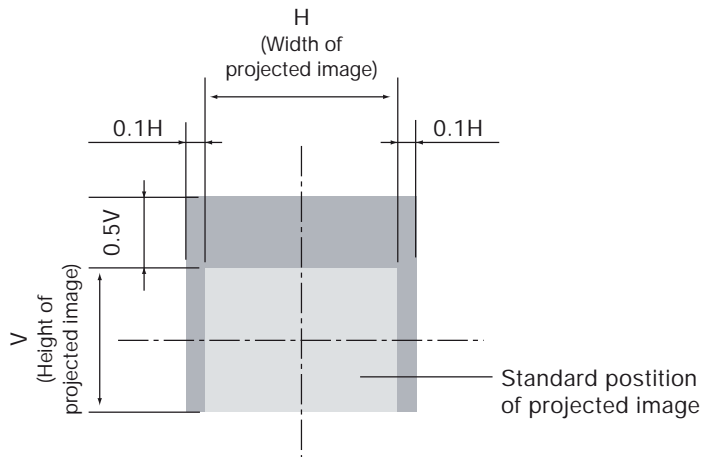

**Installable angle**

Install the projector at an angle within the range shown below.

**• Vertical direction**

The projector may be installed at a vertical angle of 360°.

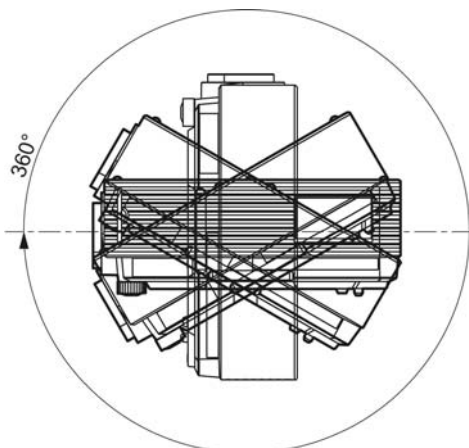

**• Horizontal direction**

The projector may be installed at a horizontal angle of ±10°.

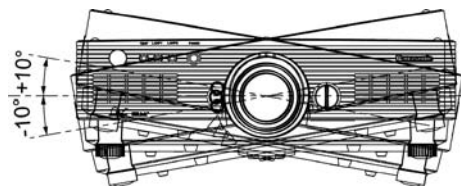

**List of compatible signals**

This projector supports RGB signals with horizontal frequencies of 15 to 91 kHz, vertical frequencies of 50 to 85 Hz and up to 150 MHz dot clock.

**NOTE:** The native resolution of this projector is 1,024 x 768 pixels. If the display resolution of the input signal is different from the native resolution, image compression or expansion will be used to convert the input signal to a level within the native resolution.

Display mode	Display resolution (dots) <sup>1</sup>	Scanning frequency		Dot clock frequency (MHz)	Picture quality <sup>2</sup>	Format
		H (kHz)	V (kHz)			
NTSC/NTSC4.43/PAL-M/PAL60	720 x 480i	15.7	59.9	-	A	VIDEO/S-VIDEO
PAL/PAL-N/SECAM	720 x 576i	15.6	50.0	-	A	
480i (525i)	720 x 480i	15.7	59.9	13.5	A	YPbPr /RGB
576i (625i)	720 x 576i	15.6	50.0	13.5	A	
480p (525p)	720 x 483	31.5	59.9	27.0	A	YPbPr /RGB/DVI
576p (625p)	720 x 576	31.3	50.0	27.0	A	
720/60p	1,280 x 720	45.0	60.0	74.3	A	
720/50p	1,280 x 720	37.5	50.0	74.3	A	
1080/60i	1,920 x 1,080i	33.8	60.0	74.3	A	
1080/50i	1,920 x 1,080i	28.1	50.0	74.3	A	
1080/60p	1,920 x 1,080	67.5	60.0	148.5	A	
1080/50p	1,920 x 1,080	56.3	50.0	148.5	A	
VGA400	640 x 400	31.5	70.1	25.2	A	RGB
		37.9	85.1	31.5	A	
VGA480	640 x 480	31.5	59.9	25.2	A	RGB/DVI
		35.0	66.7	30.2	A	RGB
		37.9	72.8	31.5	A	
		37.5	75.0	31.5	A	
		43.3	85.0	36.0	A	
SVGA	800 x 600	35.2	56.3	36.0	A	
		37.9	60.3	40.0	A	RGB/DVI
		48.1	72.2	50.0	A	RGB
		46.9	75.0	49.5	A	
		53.7	85.1	56.3	A	
MAC16	832 x 624	49.7	74.6	57.3	A	
XGA	1,024 x 768	39.6	50.0	51.9	AA	RGB/DVI
		48.4	60.0	65.0	AA	
		56.5	70.1	75.0	AA	
		60.0	75.0	78.8	AA	
		68.7	85.0	94.5	AA	
		35.5	87.0	44.9	AA	RGB
WXGA	1,280 x 768	39.6	50.0	65.2	A	RGB/DVI
		47.7	60.0	80.1	A	
	1,280 x 800	41.3	50.0	68.0	A	RGB
		49.7	59.8	83.5	A	
MXGA	1,152 x 864	64.0	71.2	94.2	A	
		67.5	74.9	108.0	A	
		76.7	85.0	121.5	A	
MAC21	1,152 x 870	68.7	75.1	100.0	A	
MSXGA	1,280 x 960	60.0	60.0	108.0	A	
SXGA	1,280 x 1,024	64.0	60.0	108.0	A	RGB/DVI
		80.0	75.0	135.0	A	RGB
		91.1	85.0	157.5	A	
SXGA+	1,400 x 1,050	64.0	60.0	108.0	A	RGB/DVI
UXGA	1,600 x 1,200	75.0	60.0	162.0	A	RGB

1. The "i" appearing after the resolution indicates an interlaced signal.

2. The following symbols are used to indicate picture quality.

AA Maximum picture quality can be obtained.

A Signals are converted by the image processing circuit before picture is projected.

**Serial connector**

The serial connector complies with RS-232C. To control the projector from a personal computer, commands must be input through communication software, based on the format and satisfying the communication conditions shown below.

**Pin assignments and signal names**

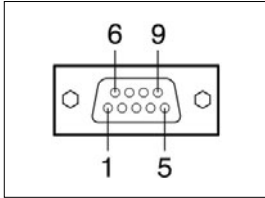

D-sub 9-pin (female)  
Serial input

No.	Signal name	Description	No.	Signal name	Description
1	-	NC	6	-	NC
2	TXD	Send data	7	CTS	Connected internally
3	RXD	Receive data	8	RTS	Connected internally
4	-	Connected internally	9	-	NC
5	GND	Ground			

**Pin assignments and signal names**

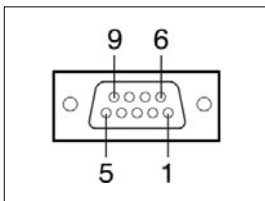

D-sub 9-pin (male)  
Serial output

No.	Signal name	Description	No.	Signal name	Description
1	-	NC	6	-	NC
2	RXD	Receive data	7	RTS	Connected internally
3	TXD	Send data	8	CTS	Connected internally
4	-	Connected internally	9	-	NC
5	GND	Ground			

**Communication conditions (factory setting)**

Signal level	RS-232C-compliant
Synchronization method	Start-stop synchronization
Baud rate	9,600 bps
Parity	None
Character length	8 bits
Stop bit	1 bit
X parameter	None
S parameter	None

**Basic format**

Transmission from the computer begins with STX, then the ID, command, parameter, and ETX are sent in this order. Add parameters according to the details of control.

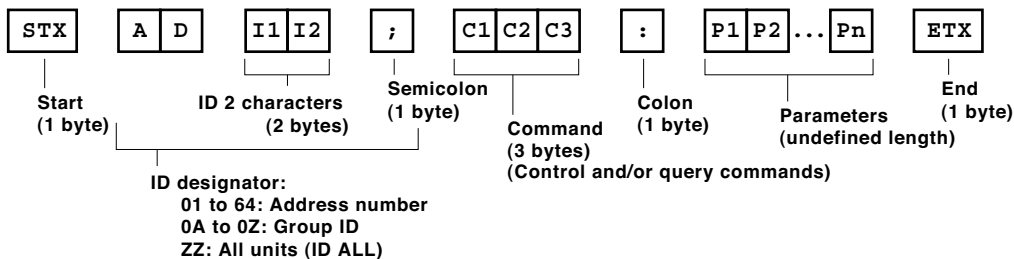

**CAUTION**

- It may not be possible to send or receive commands for about 10 to 60 seconds when the lamp is first turned on. If this occurs, wait for 60 seconds, then try sending or receiving again.
- When sending multiple commands, be sure to wait for at least 0.5 second after receiving a response from the projector before sending the next command.
- Additional time is sometimes required for response due to processing inside the projector. Set the time-out period for command response to 10 seconds or more.

**Cable specifications**

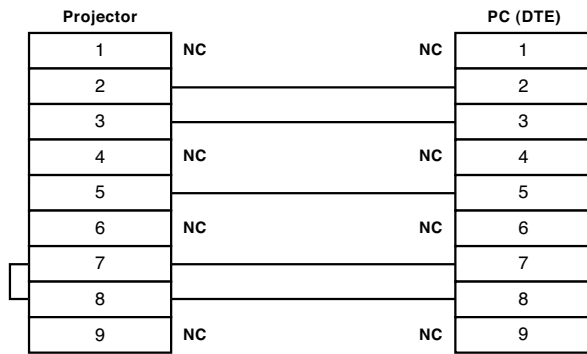

**Control commands**

Item	Command : Parameter	Function	Callback
POWER	PON*1	Power on	PON
	POF*1	Standby power off	POF
FREEZE	OFZ : 0	Freeze off	OFZ : 0
	OFZ : 1	Freeze on	OFZ : 1
AUTO SETUP	OAS	Auto setup	OAS
SHUTTER	OSH : 0 *1/*2	Shutter off	OSH : 0
	OSH : 1 *1/*2	Shutter on	OSH : 1
INPUT SELECT	IIS : RG1	RGB 1	IIS : RG1
	IIS : RG2	RGB 2	IIS : RG2
	IIS : VID	Video	IIS : VID
	IIS : SVD	S-Video	IIS : SVD
	IIS : DVI	DVI	IIS : DVI
TEST	OTS : 00	Exit test pattern	OTS : 00
	OTS : 01	White (full on)	OTS : 01
	OTS : 02	Black (full off)	OTS : 02
	OTS : 03	Flag	OTS : 03
	OTS : 05	Window	OTS : 05
	OTS : 07	Focus	OTS : 07
	OTS08	Color bar	OTS08
ON SCREEN	OOS : 0	On-screen display off	OOS : 0
	OOS : 1	On-screen display on	OOS : 1

\* 1 Do not send PON, POF, OSH, or OLP commands continuously in a short period of time. Doing so may burst the lamp or shorten the lamp replacement cycle.  
 \* 2 When a command that cannot be executed during standby mode is sent, the projector will send an ER401 command in reply.

**Adjustment mode**

Item	Command : Parameter	Description	Callback : Parameter	Parameter value	
				Min.	Max.
PICTURE MODE	VPM : NAT	Natural	VPM : NAT	-	-
	VPM : STD	Standard	VPM : STD	-	-
	VPM : DYN	Dynamic	VPM : DYN	-	-
	VPM : CIN	Cinema	VPM : CIN	-	-
	VPM : GRA	Graphic	VPM : GRA	-	-
SYSTEM	VXX : DLVI0 = +00000	Off	VXX : DLVI0 = +00000	-	-
DAYLIGHT	VXX : DLVI0 = +00001	1	VXX : DLVI0 = +00001	-	-
VIEW	VXX : DLVI0 = +00002	2	VXX : DLVI0 = +00002	-	-
	VXX : DLVI0 = +00003	3	VXX : DLVI0 = +00003	-	-
COLOR	VCO : p1p2p3	Color	VCO : p1p2p3	1	63
TINT	VTN : p1p2p3	Tint	VTN : p1p2p3	1	63
COLOR TEMP.	OTE : 1	Middle	OTE : 1	-	-
	OTE : 2	High	OTE : 2	-	-
	OTE : 4	User	OTE : 4	-	-
	OTE : 10	Default	OTE : 10	-	-
CONTRAST	VCN : p1p2p3	Contrast	VCN : p1p2p3	1	63
BRIGHTNESS	VBR : p1p2p3	Brightness	VBR : p1p2p3	1	63
SHARPNESS	VSR : p1p2p3	Sharpness	VSR : p1p2p3	0	15
SET DATE	TSD : y1y2y3y4m1m2d1d2w	Date setting	TSD : y1y2y3y4m1m2d1d2w	200701011	203512317
SET TIME	TST : h1h2m1m2s1s2	Time setting	TST : h1h2m1m2s1s2	000000	235959

**Status asking commands**

Item	Command:Parameter	Function	Callback	Description
POWER CONDITION	QPW	Main power status	000	Standby (Off)
			001	On
FREEZE	QFZ	Freeze function status	0	Off
			1	On
SHUTTER	QSH	Shutter function status	0	Off
			1	On
INPUT SIGNAL	QIN	Input signal status	RG1	RGB 1
			RG2	RGB 2
			VID	Video
			SVD	S-Video
			DVI	DVI
TEST	QTS	Test pattern status	0	Exit test pattern
			1	White (full on)
			2	Black (full off)
			3	Flag
			5	Window
			7	Focus
			8	Color bar
			ON SCREEN	QOS
			1	On
PICTURE MODE	QPM	Picture mode status	NAT	Natural
			STD	Standard
			DYN	dynamic
			CIN	Cinema
			GRA	Graphic
SYSTEM DAYLIGHT VIEW	QVX:DLVIO	System daylight view status	DLVIO=+00000	Off
			DLVIO=+00001	1
			DLVIO=+00002	2
			DLVIO=+00003	3
COLOR	QVC	Color adjustment value	p1p2p3	
TINT	QVT	Tint adjustent value	p1p2p3	
COLOR TEMP.	QTE	Color temperature adjustment status	1	Middle
			2	High
			4	User
			10	Default
CONTRAST	QVR	Contrast adjustment value	p1p2p3	
BRIGHTNESS	QVB	Brightness adjustment value	p1p2p3	
SHARPNESS	QVS	Sharpness adjustment value	p1p2p3	
SET RUNTIME	QST	Picture mode status	p1p2p3p4p5	0000h-9999h
LAMP ON TIME (LAMP TIMER)	Q\$L:1	Lamp 1 run time	p1p2p3p4	0000h-9999h
	Q\$L:2	Lamp 2 run time	p1p2p3p4	0000h-9999h
LAMP SELECT	QSL	Lamp operation mode status	0	Dual
			1	Single
			2	Lamp 1
			3	Lamp 2
VPS SYSTEM	QVY	VPS system status	0	Slave
			1	Master
TMP CHECK	QTM:0	Temperature status	p1p2p3p4/p5p6p7p8 <sup>(*)</sup>	p0 = Intake air
	QTM:1			p1 = Exhaust air
	QTM:2			p2 = DLP™ chip
GET DATE	QGD	Date setting status	y1y2y3y4m1m2d1d2w	yyyymmdd (day of week) <sup>(**)</sup>
GET TIME	QGT	Time setting status	h1h2m1m2s1s2	hhmmss <sup>(***)</sup>

\*1 p1p2p3p4: Celsius (°C), p5p6p7p8: Fahrenheit (°F)  
 \*2 Day of week: Monday = 1, Tuesday = 2, ... Sunday = 7  
 \*3 Set the date and time to UTC (universal time coordinated).

**Parameter format**

Parameter format	Size (Byte)	Definition
<pl>	3 (1 or 2 bytes also possible when under control)	Dicimal without signs: 0-999 (000, 001, 002...999) Dicimal with signs: -99 to +99 (-99...-01, +00, +01, +02...+99) Callback from the projector is 3 Byte.
<off on>	1	0 = off, 1 = on
<input signal>	3	RG1 = computer 1, RG2 = computer 2, VID = video, SVD = S-Video, DVI = DVI
<installation>	1	0 = front, 1 = rear, 2 = ceiling and front, 3 = ceiling and rear
<language>	3	ENG = English, DEU = German, FRA = French, ESP = Spanish, ITL = Italian, JPN = Japanese, CHI = Chinese, RUS = Russian, KOR = Korean
<power condition>	3	000 = standby power off, 001 = standby power on
<lamp on time>	4	Decimal without signs: 0000-9999 hours
<lamp select>	1	0 = dual, 1 = single, 2 = lamp 1, 3 = lamp 2
<acctch>	4	Decimal without signs: 0000-9999 hours
<color temp>	2	1 = mid, 2 = high, 4 = user, 10 = default
<date>	9	y1y2y3y4m1m2d1d2w = year (y) month (m) day (d) day of week (w) Day of week: Monday = 1, Tuesday = 2, ... Sunday = 7
<time>	6	h1h2m1m2s1s2 = hour (h) minute (m) second (s)

**NOTE: If a wrong command is received, the projector will send an ER401 command to the computer.**

**Command example**

To set the on-screen display off, send the command as shown below.

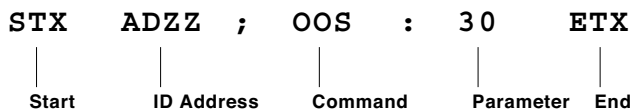

**NOTE: When sending commands without parameters, a colon (:) is not necessary.**

**Notes on Projector Placement and Operation:**

The projector uses a high-wattage lamp that becomes very hot during operation. Please observe the following precautions.

1. Never place objects on top of the projector while it is operating.
2. Make sure there is an unobstructed space of 500 mm or more around the projector's exhaust openings.
3. Do not stack projector units directly on top of one another. If two units must be stacked for back-up use in ordinary projection, use a method as shown below and provide ample space between the units to ensure that exhaust heat does not accumulate near the intake opening or around the units. Dual stacked projection of the PT-D4000 is not recommended.
4. If the projector is placed in a box or enclosure, ensure the temperature of the air surrounding the projector is between 0°C/32°F and 40°C/104°F\*. Also make sure the projector's intake and exhaust openings are not blocked. Take particular care to ensure that hot air from the exhaust openings is not sucked into the intake openings.

\* Even when the ambient temperature near the intake opening is 40°C/104°F or lower, an accumulation of hot air inside the cabinet may cause the protective circuit to activate and shut down the projector. Please give ample consideration to the design with regard to ambient temperature conditions.

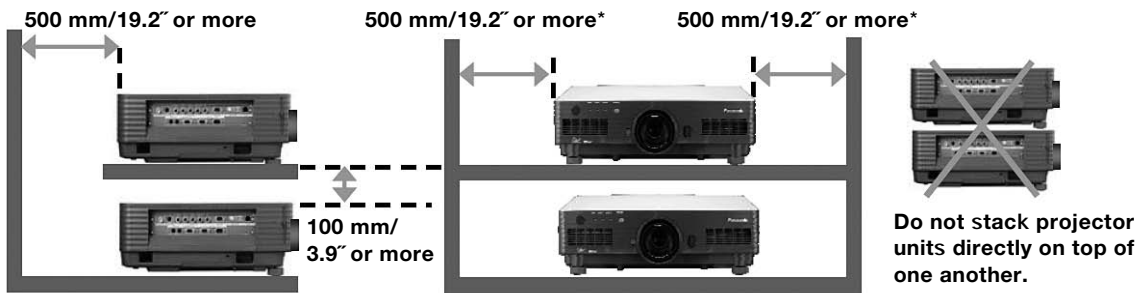

\* Minimum distance when two units are used together.  
Keep 300 mm/11.8" or more when a single unit is used.

**Direction of Air Intake and Exhaust**

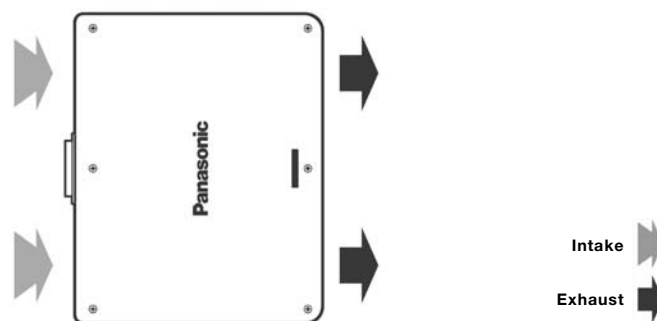

**Operating the Projector Continuously:**

1. If the projector is to be operated continuously 24 hours a day, use the dual-lamp optical system's alternating lamp operation (lamp changer) function. The projector cannot be operated continuously 24 hours a day in dual-lamp mode.  
Allow a minimum of two hours per day of non-operation time.
2. The lamp replacement cycle duration becomes shorter if the projector is operated repeatedly for short periods.

DLP and the DLP logo are trademarks of Texas Instruments. UHM is a trademark of Matsushita Electric.  
PJLink is a registered trademark, or a trademark application has been filed, in Japan, the United States, and other countries and regions.  
VGA and XGA are registered trademarks of International Business Machines Corporation.  
All other trademarks are the property of their respective trademark owners.