

---

## S P E C F I L E

---

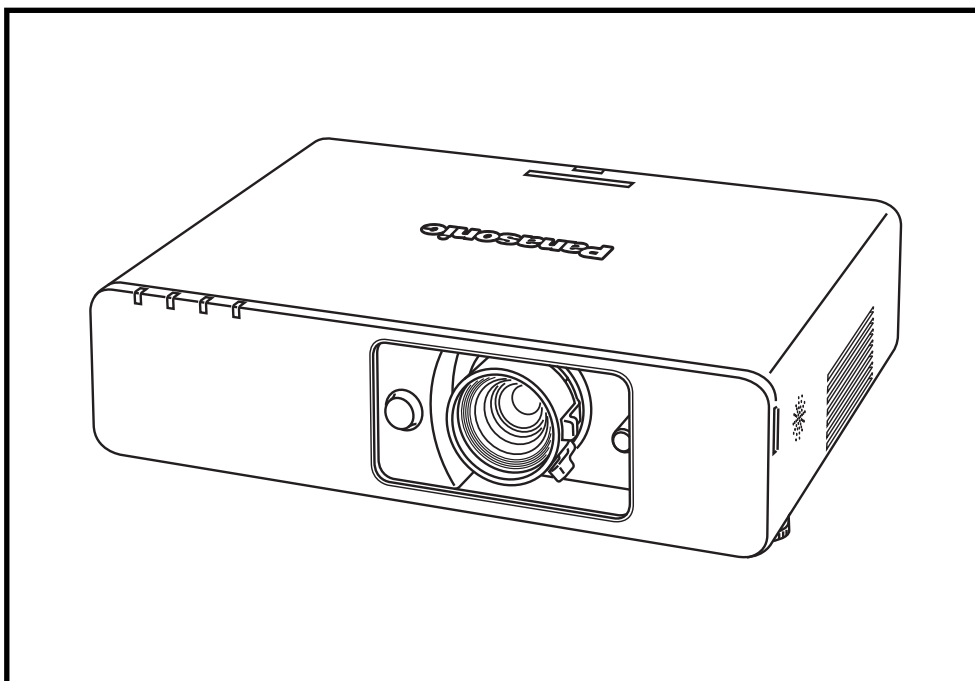

Product Number : **PT-F200NT**

Product Name : LCD Projector

## Specifications

Power supply		100–240 V AC, 50/60 Hz
Power consumption		330 W (Approx. 4.5 W in standby mode with fan stopped. 25 W in standby mode when controlled by a Web browser.)
Optical system		Dichroic mirror separation/prism synthesis system
LCD panel	Panel size	0.7" (17.78 mm) diagonal, 4:3 aspect ratio
	Display method	Transparent LCD panel (x 3, R/G/B)
	Drive method	Active matrix
	Pixels	786,432 (1,024 x 768) x 3, total of 2,359,296 pixels
	Pixel configuration	Stripe
Lens		Manual zoom (1:1–1:2), manual focus F 1.7–2.6, f 21.6–43.0 mm
Lamp		250 W UHM™ lamp
Colors		Full color (16,777,216 colors)
Brightness*1		3,500 lumens
Center-to-corner uniformity*1		80%
Contrast ratio*1		400:1 (full on/full off)
Resolution	RGB	1,024 x 768 pixels (Input signals that exceed this resolution will be converted to 1,024 x 768 pixels.)
Scanning frequency	RGB	Horizontal: 15–91 kHz, Vertical: 50–85 Hz
	YPbPr	480i (525i): fH 15.75 kHz; fV 60 Hz 576i (625i): fH 15.63 kHz; fV 50 Hz 480p (525p): fH 31.50 kHz; fV 60 Hz 576p (625p): fH 31.25 kHz; fV 50 Hz 720/60p (750p): fH 45.00 kHz; fV 60 Hz 720/50p (750p): fH 37.50 kHz; fV 50 Hz 1080/60i (1125i): fH 33.75 kHz; fV 60 Hz 1080/50i (1125i): fH 28.13 kHz; fV 50 Hz
	S-Video/Video	NTSC, NTSC4.43, PAL-M, PAL60: fH 15.75 kHz; fV 60 Hz PAL, SECAM, PAL-N: fH 15.63 kHz; fV 50 Hz
Projection size		838–7,620 mm (33–300 inches) diagonally, 16:10 aspect ratio
Throw distance		1.2 m–18.1 m (3'11"–59'5"), 4:3 aspect ratio
Optical axis shift		Vertical: ±50%, horizontal: ±32%
Keystone correction range		Vertical: approx. ±30°
Installation		Front/rear, ceiling/desk (menu selection)
On-screen menu		17 languages: English, French, German, Spanish, Italian, Korean, Russian, Chinese, Japanese, Swedish, Norwegian, Danish, Portuguese, Polish, Hungarian, Czech, and Thai
Built-in speakers	Size	4 cm (round), x 1
	Output power	3.0 W (monaural)
Terminals	COMPUTER 1 IN	D-sub HD 15-pin x 1 R, G, B: 0.7 Vp-p, 75 ohms, Sync on green: 1.0 V [p-p], 75 ohms, HD/SYNC, VD: TTL (positive/negative polarity compatible)
	COMPUTER 2 IN/COMPUTER 1 OUT	D-sub HD 15-pin x 1 (input/output selectable using on-screen menu) R, G, B: 0.7 V [p-p], 75 ohms, Sync on green: 1.0 V [p-p], 75 ohms, HD/SYNC, VD: TTL (positive/negative polarity compatible)
	COMPONENT IN	RCA pin x 3, Y: 1.0 V [p-p] (including sync signal), 75 ohms, Pb, Pr: 0.7 V [p-p], 75 ohms
	VIDEO IN	RCA pin x 1, 1.0 Vp-p, 75 ohms
	S-VIDEO IN	Mini DIN 4-pin x 1, Y: 1.0 V [p-p], C: 0.286 V [p-p], 75 ohms
	AUDIO IN (COMPUTER 1) M3 (stereo) x 1, 0.5 V [rms]	
	AUDIO IN (COMPUTER 2) M3 (stereo) x 1, 0.5 V [rms]	
	AUDIO IN (COMPONENT/VIDEO/S-VIDEO)	RCA (L, R) x 1, 0.5 V [rms]
	AUDIO OUT	M3 (stereo) x 1, 0–2.0 V [rms] (variable)
	SERIAL	D-sub 9-pin x 1, for external control (RS-232C)
	REMOTE	D-sub 9-pin x 1, for external control (contact control)
	LAN	RJ-45 x 1, 10BASE-T/100BASE-TX/1000BASE-T
Power cord length		2 m/6'7"
Cabinet material		Moulded plastic (PC+ABS)
Dimensions (W x H x D)		432 x 124.5 x 319 mm (17" x 4-29/32" x 12-9/16")
Weight		6.2 kg (13.7 lbs.)
Operating environment	Temperature	0°–40°C (32°–104°F)
	Humidity	20%–80% (no condensation)

Remote control unit	Power supply	3 V DC (AA battery x 2)
	Operation range* <sup>2</sup>	Approx. 15 m (49'3") when operated from directly in front of the signal receptor
	Dimensions (W x H x D)	48 x 163 x 24.5 mm (1-7/8" x 6-13/32" x 31/32")
	Weight	117 g (4.1 oz) (including batteries)
Wireless LAN	Standard	IEEE 802.11b/g
	Modulation	
	IEEE 802.11b	Direct sequence spread spectrum (DSSS) system
	IEEE 802.11g	Orthogonal frequency division multiplex (OFDM) system
	Transmission system	
	IEEE 802.11b	CCK (11/5.5 Mbps), DQPSK (2 Mbps), DBPSK (1 Mbps)
	IEEE 802.11g	64-QAM (54/48 Mbps), 16-QAM (36/24 Mbps), QPSK (18/12 Mbps), BPSK (9/6 Mbps)
	Transmission speed	
	IEEE 802.11b	11 Mbps, 5.5 Mbps, 2 Mbps, 1 Mbps
	IEEE 802.11g	54 Mbps, 48 Mbps, 36 Mbps, 24 Mbps, 18 Mbps, 12 Mbps, 9 Mbps, 6 Mbps
	Operating range* <sup>2</sup>	Approx. 30 m
	Frequency range	PT-F200NTE/F200NTEA: 2,412 MHz–2,472 MHz PT-F200NTU: 2,412 MHz–2,462 MHz
	Channels	PT-F200NTE/F200NTEA: 1–13 ch, PT-F200NTU: 1–11 ch
	Infrastructure mode	WPA-PSK (TKIP/AES), 128/64-bit WEP
	Ad-hoc mode	128/64-bit WEP
Wireless Manager ME 4.5 system requirements		To use network functions, a PC is required that meets the conditions given below.
	OS	Microsoft® Windows® 2000 Professional, Windows® XP Professional, Windows® XP Home Edition, Windows Vista® Ultimate 32-bit, Windows Vista® Business 32-bit, Windows Vista® Home Premium 32-bit, Windows Vista® Home Basic 32-bit Apple Mac OS X 10.4 (Tiger) and OS X 10.5* (Leopard) * MacBook and MacBook Pro with the Intel Core 2 Duo processor only. <b>NOTE: Some functions are not available with Windows Vista® and Mac.</b>
	Web browser	Windows®: Internet Explorer 6.0 or later, or Netscape Communicator 7.0 or later Mac OS: Safari 2.0 or later
	CPU	Windows®: Intel® Pentium® III or higher, or other compatible processor (1 GHz or higher is recommended.) Mac OS X 10.4: 800-MHz or higher PowerPC G4, or 1.8-GHz or higher Intel® Core™ processor Mac OS X 10.5: MacBook and MacBook Pro with the Intel® Core™ 2 Duo processor only
	Memory	256 MB or more
	Free hard disk space	60 MB or more
	CD-ROM drive	CD-ROM drive or DVD drive
	Wireless LAN	IEEE 802.11b/g compatible (built-in wireless LAN system or external IEEE 802.11b/g LAN card must be installed and running normally.) <b>NOTE: Some IEEE 802.11g/b wireless LAN may not allow connection to the projector.</b>
	Wired LAN connector	RJ-45 <b>NOTE: Use Category 5e (or higher) cables for use with 1000BASE-T.</b>
Supplied accessories		Power cord Power cord secure lock Wireless remote control Batteries for remote control Wireless Manager ME 4.5 (CD-ROM) Safety wire rope
Optional accessories		Replacement lamp unit: ET-LAF100 Replacement filter unit: ET-RFF100 Ceiling mount bracket for high ceilings: ET-PKF100H Ceiling mount bracket for low ceilings: ET-PKF100S

\*1: Measurement, measuring conditions, and method of notation all comply with ISO 21118 international standards.

\*2: Operation range differs depending on environments.

Weights and dimensions shown are approximate. Specifications are subject to change without notice. Product availability differs depending on region and country. This product may be subject to export control regulations. UHM is a trademark of Matsushita Electric Industrial Co., Ltd. Intel, Pentium, and Intel Core are trademarks or registered trademarks of Intel Corporation or its subsidiaries in the United States and other countries. Microsoft, Windows Vista and Windows are either registered trademarks or trademarks of Microsoft Corp. in the United States and/or other countries. Apple, Mac, Mac OS, and Macintosh are trademarks of Apple Inc., registered in the U.S. and other countries. PowerPC is a trademark of International Business Machines Corporation, registered in the U.S. PLink is a registered trademark or trademark in Japan, the United States, and other countries and regions All other trademarks are the property of their respective trademark owners.

Dimensions

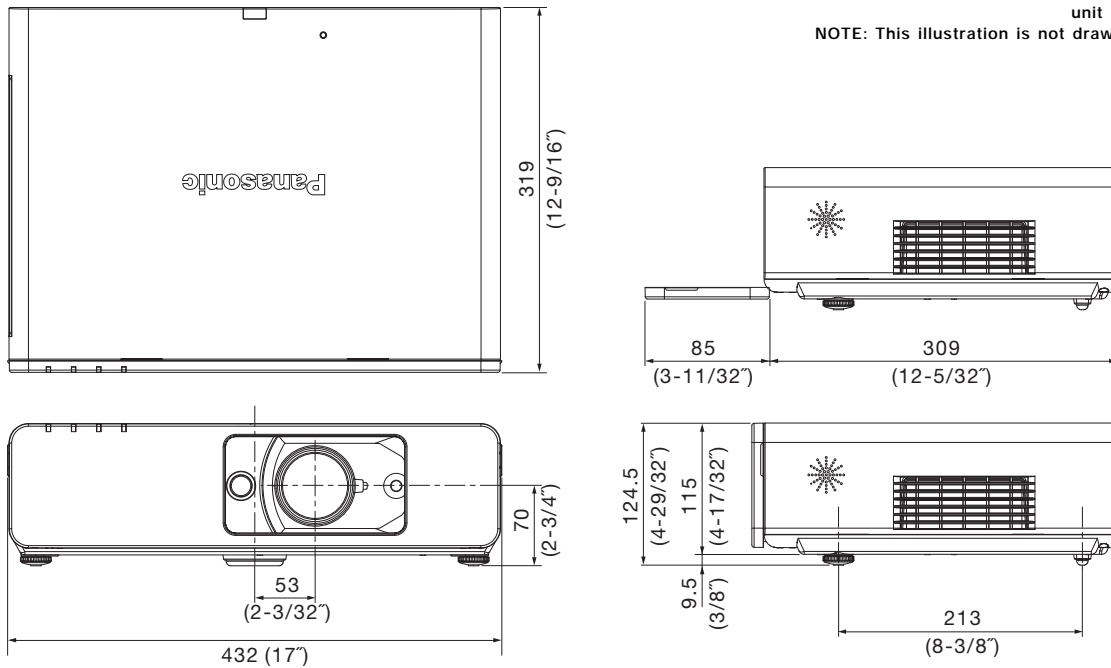

Terminals

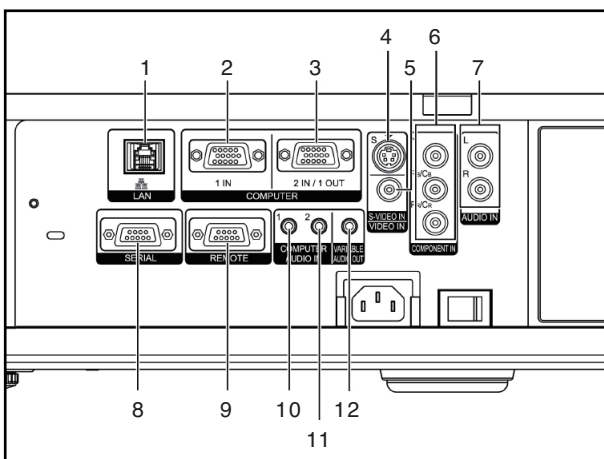

- 1 LAN
- 2 Computer 1 input
- 3 Computer 2 input/computer 1 output
- 4 S-Video input
- 5 Video input
- 6 Component input
- 7 Audio input for component/S-Video/video
- 8 Serial input
- 9 Remote input
- 10 Audio input for computer 1
- 11 Audio input for computer 2
- 12 Audio output

Standard setting-up positions

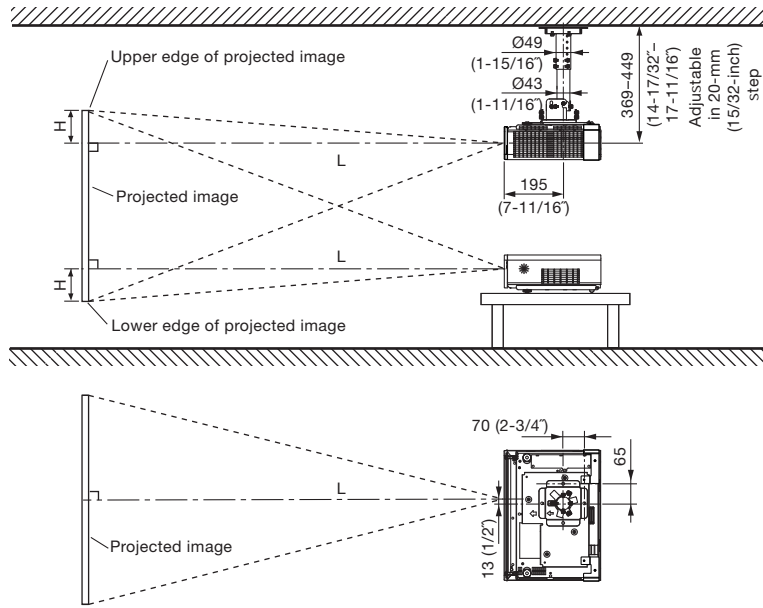

unit : mm (inch)

A: Distance to screen  
E: Height from the edge of screen to center of lens

NOTE:  
Illustrations show the projector installed using optional ceiling bracket.  
This illustration is not drawn to scale.

Projection distance (screen aspect ratio 4:3)

Projection size (diagonal)	Projection distance (L)		Height from the edge of screen to center of lens (H)
	Min (wide)	Max (telephoto)	
0.84 m / 33"	- / -	1.9 m / 6.4'	0 - 0.25 m / 0 - 0.8'
1.02 m / 40"	1.2 m / 3.8'	2.4 m / 7.8'	0 - 0.30 m / 0 - 1.0'
1.27 m / 50"	1.5 m / 4.8'	3.0 m / 9.8'	0 - 0.38 m / 0 - 1.3'
1.52 m / 60"	1.8 m / 5.8'	3.6 m / 11.7'	0 - 0.46 m / 0 - 1.5'
1.78 m / 70"	2.1 m / 6.8'	4.2 m / 13.7'	0 - 0.53 m / 0 - 1.8'
2.03 m / 80"	2.4 m / 7.8'	4.8 m / 15.7'	0 - 0.61 m / 0 - 2.0'
2.29 m / 90"	2.7 m / 8.8'	5.4 m / 17.7'	0 - 0.69 m / 0 - 2.3'
2.54 m / 100"	3.0 m / 9.8'	6.0 m / 19.7'	0 - 0.76 m / 0 - 2.5'
3.05 m / 120"	3.6 m / 11.8'	7.2 m / 23.7'	0 - 0.91 m / 0 - 3.0'
3.81 m / 150"	4.5 m / 14.8'	9.0 m / 29.6'	0 - 1.14 m / 0 - 3.8'
5.08 m / 200"	6.0 m / 19.8'	12.1 m / 39.6'	0 - 1.52 m / 0 - 5.0'
6.35 m / 250"	7.6 m / 24.8'	15.1 m / 49.5'	0 - 1.91 m / 0 - 6.3'
7.62 m / 300"	9.1 m / 29.8'	18.1 m / 59.5'	0 - 2.29 m / 0 - 7.5'

\* This distance is especially recommended for ceiling-mounted use and other permanent installations.

NOTE:  
Values shown are approximate. The value for L (distance to screen) varies slightly depending on the zoom lens characteristics.

When the shortest projection distance is used, a small amount of distortion may occur in the image due to the zoom lens characteristics.

The value for H (the height from the edge of the screen to the centre of the lens) is the value when the horizontal optical axis shift function is not used. The value decreases when the horizontal optical axis shift function is used. For details, see Shift range on page 6.

Calculation of the projection distance

For a screen size different from the above, use the equation below to calculate the projection distance.

Aspect ratio 4:3

minimum L (m) = (diagonal screen size in inches) x 0.0304 - 0.048  
 maximum L (m) = (diagonal screen size in inches) x 0.0606 - 0.057

NOTE:  
Distances calculated with the above equations will include a slight error.

**Shift range**

Optical axis shift function allows to shift the position of a projected image as shown below.

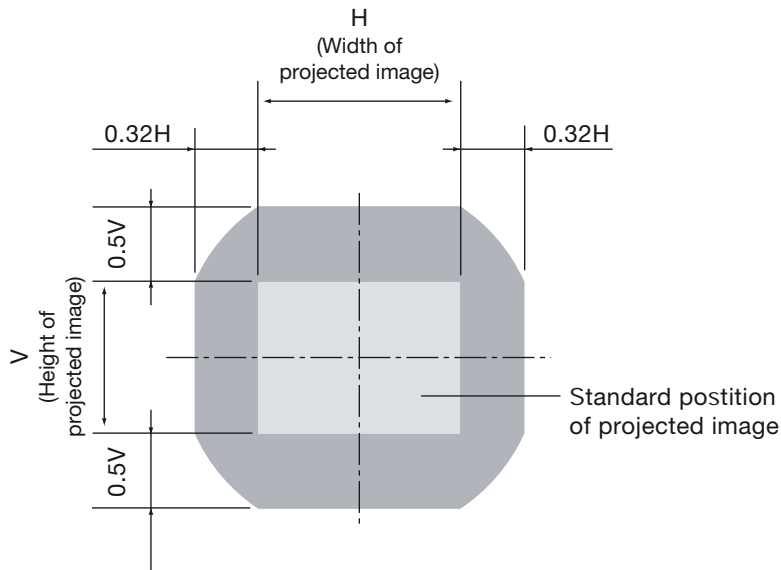

**Installable Angle**

Install the projector at an angle within the range shown below..

**• Vertical direction**

The projector may be installed at a vertical angle of  $\pm 30^\circ$ .

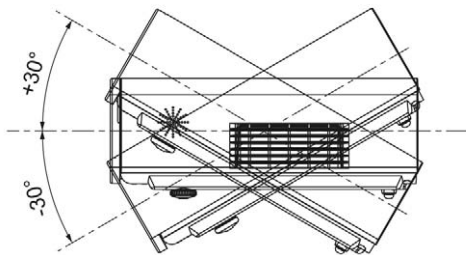

**• Horizontal direction**

The projector may not be angled horizontally.

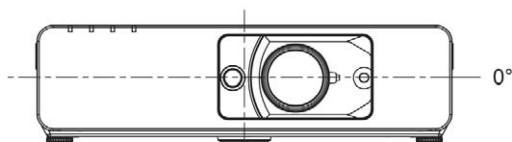

**Computer data compatibility**

This projector accepts up to 91 kHz horizontal scanning frequency and 162 MHz dot clock.

**NOTE:** Pixel thinning is applied to signals that exceed a dot clock frequency of 110 MHz. The display resolution of this projector is 1,024 x 768 pixels. If the display resolution indicated in the above data exceeds this resolution, image compression will be used to convert the input signal to 1,024 x 768 pixels.

**List of compatible signals**

Display mode	Display resolution (dots) <sup>1</sup>	Scanning frequency H (kHz)	V (kHz)	Dot clock frequency (MHz)	Picture quality <sup>2</sup>	Input terminal
NTSC/NTSC4.43/PAL-M/PAL60	720 x 480i	15.7	59.9	-	A	VIDEO/S-VIDEO
PAL/PAL-N/SECAM	720 x 576i	15.6	50.0	-	A	
525i (480i)	720 x 480i	15.7	59.9	13.5	A	COMPONENT (YPbPr)/ COMPUTER (RGB only)
625i (576i)	720 x 576i	15.6	50.0	13.5	A	
525p (480p)	720 x 480	31.5	59.9	27.0	A	
625p (576p)	720 x 576	31.3	50.0	27.0	A	
750 (720)/60p	1,280 x 720	45.0	60.0	74.3	A	COMPONENT (YPbPr)/ COMPUTER (RGB only)
750 (720)/50p		37.5	50.0	74.3	A	COMPUTER (RGB only)
1125 (1080)/60i	1,920 x 1,080i	33.8	60.0	74.3	A	COMPONENT (YPbPr)/ COMPUTER (RGB only) <sup>3</sup>
1125 (1080)/50i		28.1	50.0	74.3	A	COMPUTER (RGB only)
VESA70	640 x 400	31.5	70.1	25.2	A	COMPUTER (RGB only)
VESA85		37.9	85.1	31.5	A	
VGA60	640 x 480	31.5	59.9	25.2	A	
VGA65		35.0	66.7	30.2	A	
VGA72		37.9	72.8	31.5	A	
VGA75		37.5	75.0	31.5	A	
VGA85		43.3	85.0	36.0	A	
SVGA55	800 x 600	35.2	56.3	36.0	A	
SVGA60		37.9	60.3	40.0	A	
SVGA70		48.1	72.2	50.0	A	
SVGA75		46.9	75.0	49.5	A	
SVGA85		53.7	85.1	56.3	A	
MAC16	832 x 624	49.7	74.6	57.3	A	
XGA50	1,024 x 768	39.6	50.1	51.9	AA	
XGA60		48.4	60.0	65.0	AA	
XGA70		56.5	70.1	75.0	AA	
XGA75		60.0	75.0	78.8	AA	
XGA85		68.7	85.0	94.5	AA	
WIDE750 (720)	1,280 x 720	44.8	59.9	74.5	A	
		37.1	49.8	60.5	A	
WXGA768/50	1,280 x 768	39.6	49.9	65.3	A	
WXGA768/60		47.8	59.9	79.5	A	
WXGA800/50	1,280 x 800	41.3	50.0	68.0	A	
WXGA800/60		49.1	60.2	69.1	A	
		49.7	59.8	83.5	A	
MXGA70	1,152 x 864	64.0	71.2	94.2	A	
MXGA75		67.5	74.9	108.0	A	
MXGA85		76.7	85.0	121.5	B	
MAC21	1,152 x 870	68.7	75.1	100.0	A	
MSXGA60	1,280 x 960	60.0	60.0	108.0	A	
SXGA60	1,280 x 1,024	64.0	60.0	108.0	A	
SXGA75		80.0	75.0	135.0	B	
SXGA85		91.1	85.0	157.5	B	
SXGA60+	1,400 x 1,050	64.0	60.0	108.0	A	
		65.1	59.9	122.4	B	
WXGA+	1,440 x 900	55.9	59.9	106.5	A	
UXGA60	1,600 x 1,200	75.0	60.0	162.0	B	
WSXGA+	1,680 x 1,050	65.3	60.0	146.3	B	
WUXGA	1,920 x 1,200	74.6	59.9	193.3	B	

1. The "i" appearing after the resolution indicates an interlaced signal.

2. The following symbols are used to indicate picture quality.

AA: Maximum picture quality can be obtained. A: Signals are converted by the image processing circuit before picture is projected.

B: Pixels are thinned by the image processing circuit before picture is projected.

3. When 750 (720)/60p or 750 (720)/50p signals are input to a computer input terminal, images are projected in the WIDE750 (720) format. Be sure to run the auto setup function.

**Serial connector**

The serial connector complies with RS-232C. To control the projector from a personal computer, commands must be input through communication software, based on the format and satisfying the communication conditions shown below.

**Pin assignments and signal names**

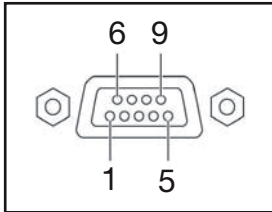

D-sub HD 9-pin, female

No.	Signal name	Description	No.	Signal name	Signal name
1	-	NC	6	-	NC
2	TXD	Send data	7	CTS	Connected internally
3	RXD	Receive data	8	RTS	Connected internally
4	-	Connected internally	9	-	NC
5	GND	Ground			

\* Effective when connected to a PC having proper functions.

**Communication conditions (factory setting)**

Signal level	RS-232C-compliant
Synchronization method	Start-stop synchronization
Baud rate	9,600 bps
Parity	None
Character length	8 bits
Stop bit	1 bit
X parameter	None
S parameter	None

**Basic format**

Transmission from the computer begins with STX, then the ID, command, parameter, and ETX are sent in this order. Add parameters according to the details of control.

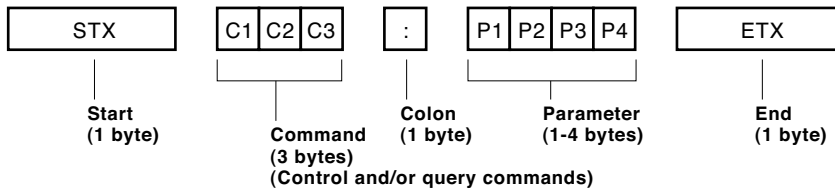

**CAUTION**

It may not be possible to send or receive commands for about 10 to 60 seconds when the lamp is first turned on. If this occurs, wait for 60 seconds, then try sending or receiving again. When sending multiple commands, be sure to wait for at least 0.5 second after receiving a response from the projector before sending the next command. Additional time is sometimes required for response due to processing inside the projector. Set the time-out period for command response to 10 seconds or more.

**NOTE:**

If a wrong command is received, the projector will send an ER401 command to the computer. When sending commands without parameters, a colon (:) is not necessary.

**Cable specifications**

Projector		PC (DTE)	
1	NC	NC	1
2			2
3			3
4	NC	NC	4
5			5
6	DSR	NC	6
7			7
8			8
9	NC	NC	9

**Control commands**

Command: <Parameter>	Function	Callback: <Parameter>	Parameter value	
			Min	Max
PON*1	Power on (standby mode on)	PON	-	-
POF*1	Power off (standby mode off)	POF	-	-
AVL:<p1>	Volume control	AVL:<p1>	0	63
IIS:<input signal>	Input signal selection	IIS:<input signal>	-	-
OST	The same function as "default" button	OST	-	-
OFZ:<off on>	Freeze	OFZ:<off_on>	0	1
OEN	Enter	OEN	-	-
OXG:<off on>	Wide mode	OXG:<off_on>	0	1
VPM:<NAT>	Picture mode: Natural	VPM:<NAT>	-	-
VPM:<STD>	Picture mode: Standard	VPM:<STD>	-	-
VPM:<DYN>	Picture mode: Dynamic	VPM:<DYN>	-	-
VPM:<BBD>	Picture mode: Blackboard	VPM:<BBD>	-	-
VXX:DLVI0=<+00000>	Daylight View: Off	VXX:DLVI0=<+00000>	-	-
VXX:DLVI0=<+00001>	Daylight View: Auto	VXX:DLVI0=<+00001>	-	-
VXX:DLVI0=<+00002>	Daylight View: On	VXX:DLVI0=<+00002>	-	-
AUU	Volume up	AUU	-	-
AUD	Volume down	AUD	-	-
OMN	Menu	OMN	-	-
OCU	Cursor up	OCU	-	-
OCD	Cursor down	OCD	-	-
OCL	Cursor left	OCL	-	-
OCR	Cursor right	OCR	-	-
OAS	Auto setup	OAS	-	-
OSH*1/*2	Shutter	OSH	-	-
OIX	Index window	OIX	-	-
DZU	Digital zoom: Enlargement	DZU	-	-
DZD	Digital zoom: Reduction	DZD	-	-
TSD:<date>	Date setting	TSD:<date>	-	-
TST:<time>	Time setting	TST:<time>	-	-

\* 1 Do not send PON, POF, or OSH commands continuously in a short period of time. Doing so may burst the lamp or shorten the lamp replacement cycle.

\* 2 When a command other than OSH is sent while the shutter function is operating, the projector will send an ER401 command in reply and release the shutter function.

**Status asking commands**

Command	Description	Callback <Parameter>
QPW	Standby power status	<power condition>
QSS	Lamp status	<lamp condition>
QIN	Input signal status	<input signal>
QAV	Volume adjustment value	<p1>
QVC	Color adjustment value	<p1>
QVT	Tint adjustent value	<p1>
QVB	Brightness adjustment value	<p1>
QVR	Contrast adjustment value	<p1>
QVS	Sharpness adjustment value	<p1>
QWR	White balance: R adjustment value	<p1>
QWG	White balance: G adjustment value	<p1>
QWB	White balance: B adjustment value	<p1>
QHP	Horizontal position adjustment value	<p1>
QVP	Vertical position adjustment value	<p1>
QCP	Clock phase adjustment value	<p1>
QDC	Dot clock adjustment value	<p1>
QSP	Projection method status	<p1>
QLG	On-screen menu language	<p1>
QXG	Wide mode status	<off_on>
QVX:DLVI0	Daylight View status	Off <+00000>
		Auto <+00001>
		On <+00002>
QPM	Picture mode status	Natural <NAT>
		Standard <STD>
		Dynamic <DYN>
		Blackboard <BBD>
QFZ	Freeze status	<off_on>
QSL	Lamp run time	<acctch>
QSH	Shutter function status	<off_on>
QKS	Keystone correction status	<p1>
QTE	Color temperature adjustment status	<color temp>
QGD	Date setting status	<date>
QGT	Time setting status	<time>

**Parameter format**

Parameter format	Size (Byte)	Difinition
<pl>	3 (1 or 2 bytes also possible when under control)	Dicimal without signs: 0-999 (000, 001, 002...999) Dicimal with signs: -99 to +99 (-99...-01, +00, +01, +02...+99) Callback from the projector is 3 Byte.
<off on>	1	0 = off, 1 = on
<input signal>	3	RG1 = computer 1, RG2 = computer 2, NWP = network, YUV = component, VID = video, SVD = S-Video
<installation>	1	0 = front, 1 = rear, 2 = ceiling and front, 3 = ceiling and rear
<language>	3	ENG = English, DEU = German, FRA = French, ESP = Spanish, ITL = Italian, JPN = Japanese, CHI = Chinese, POR = Portuguese, SVE = Swedish, NOR = Norwegian, DAN = Danish, POL = Polish, CES = Czech, MAG = Hungarian, RUS = Russian, THA = Thai, KOR = Korean
<power condition>	3	000 = power on (standby mode on), 001 = power off (standby mode off)
<lamp condition>	1	0 = standby, 1 = lamp on under control, 2 = lamp off, 3 = lamp off under control
<acctch>	4	Dicimal without signs: 0000-9999 hours
<color temp>	1	0 = economy, 1 = normal
<date>	8	y1y2y3y4m1m2d1d2w = year (y) month (m) day (d) day of week (w) Day of week: Monday = 1, Tuesday = 2, ... Sunday = 7
<time>	6	h1h2m1m2s1s2 = hour (h) minute (m) second (s)

NOTE: If a wrong command is received, the projector will send an ER401 command to the computer.

**Command example**

To set the volume to +30, send the command as shown below.

**STX    AVL    :    30    ETX**  
 |            |            |            |  
**Start    Command    Parameter    End**

NOTE: When sending commands without parameters, a colon (:) is not necessary.

**Notes on Projector Placement and Operation:**

The projector uses a high-wattage lamp that becomes very hot during operation. Please observe the following precautions.

1. Never place objects on top of the projector while it is operating.
2. Make sure there is an unobstructed space of 500 mm (19-11/16") or more around the projector's exhaust openings. In addition to this space, also ensure that there is a sufficient work space for removing and installing the lamp, filter and other parts.
3. If the projector is placed in a box or enclosure, ensure the temperature of the air surrounding the projector is between 0°C/32°F and 35°C/95°F. Also make sure the projector's intake and exhaust openings are not blocked. Take particular care to ensure that hot air from the exhaust openings is not sucked into the intake openings.

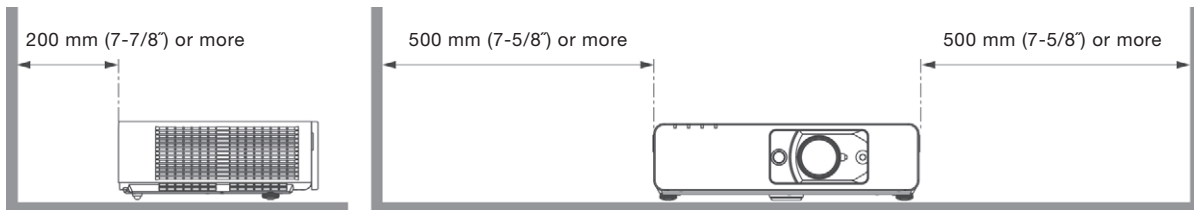

**Direction of Air Intake and Exhaust**

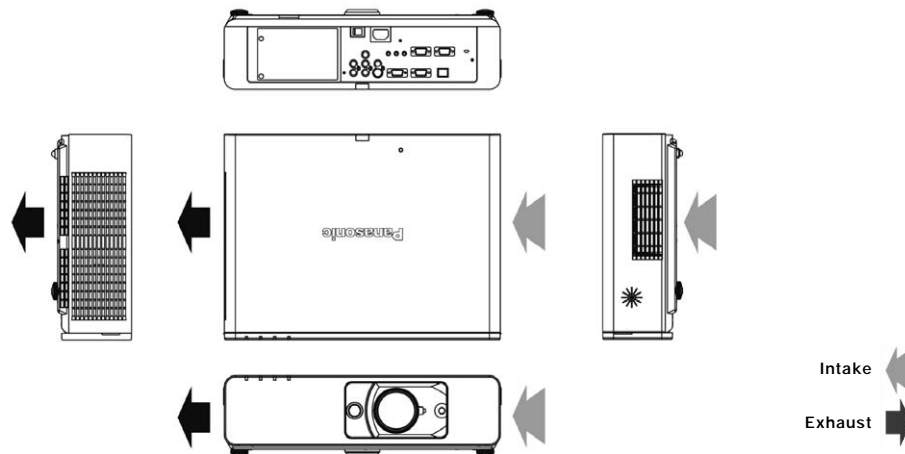

**Operating the Projector Continuously**

1. When the projector is operated continuously 10 hours or more, the lamp replacement cycle decreases.
2. The lamp replacement cycle also decreases when the projector is used for short periods of time (less than one hour) repeatedly.

**Replacing the Filter Unit**

The projector is equipped with the Auto Rolling Filter (ARF) function, which automatically winds the air filter to set a new filter element in place according to operating conditions. The filter unit replacement cycle ranges from approximately 6,000 hours maximum to approximately 500 hours minimum. Please purchase the ET-RFF100 filter unit for replacement use.

Weights and dimensions shown are approximate. Specifications are subject to change without notice. Product availability differs depending on region and country. This product may be subject to export control regulations. UHM is a trademark of Matsushita Electric Industrial Co., Ltd. Intel, Pentium, and Intel Core are trademarks or registered trademarks of Intel Corporation or its subsidiaries in the United States and other countries. Microsoft, Windows Vista and Windows are either registered trademarks or trademarks of Microsoft Corp. in the United States and/or other countries. Apple, Mac, Mac OS, and Macintosh are trademarks of Apple Inc., registered in the U.S. and other countries. PowerPC is a trademark of International Business Machines Corporation, registered in the U.S. PJLink is a registered trademark or trademark in Japan, the United States, and other countries and regions All other trademarks are the property of their respective trademark owners.