

# **BASIC SERIAL COMMAND SPECIFICATIONS**

**PLC-WL2500  
PLC-WL2501**

**Ver.1.00**

**SANYO Electric Co., Ltd  
DS Company  
Projector Division**

**- CONTENTS -**

<b>1. Overview .....</b>	<b>4</b>
<b>2. Serial Interface Specifications .....</b>	<b>4</b>
<b>2.1. Transfer Specifications .....</b>	<b>4</b>
<b>2.2. Connection .....</b>	<b>4</b>
<b>3. Notes for Communication .....</b>	<b>5</b>
<b>4. Functional Execution Command Table.....</b>	<b>6</b>
<b>5. Status Read Command Table.....</b>	<b>8</b>
<b>6. Functional Execution Command .....</b>	<b>9</b>
<b>6.1. Format .....</b>	<b>9</b>
<b>6.2. Command Pipelining .....</b>	<b>9</b>
<b>6.3. Transfer Example .....</b>	<b>9</b>
<b>6.4. Operation Requirements .....</b>	<b>10</b>
<b>6.5. POWER ON Command .....</b>	<b>11</b>
<b>6.6. POWER OFF Command (Quick Power OFF).....</b>	<b>11</b>
<b>6.7. POWER OFF Command.....</b>	<b>11</b>
<b>6.8. HDMI Command .....</b>	<b>11</b>
<b>6.9. Computer 1 Command .....</b>	<b>11</b>
<b>6.10. Computer 2 Command .....</b>	<b>12</b>
<b>6.11. Video Command.....</b>	<b>12</b>
<b>6.12. VOLUME + Command .....</b>	<b>12</b>
<b>6.13. VOLUME – Command .....</b>	<b>12</b>
<b>6.14. AUDIO MUTE ON Command .....</b>	<b>12</b>
<b>6.15. AUDIO MUTE OFF Command .....</b>	<b>13</b>
<b>6.16. VIDEO MUTE ON Command .....</b>	<b>13</b>
<b>6.17. VIDEO MUTE OFF Command.....</b>	<b>13</b>
<b>6.18. Screen Normal size Command .....</b>	<b>13</b>
<b>6.19. Screen Full size Command .....</b>	<b>13</b>
<b>6.20. Image Standard Command .....</b>	<b>13</b>
<b>6.21. Image Real Command .....</b>	<b>14</b>
<b>6.22. Image Cinema Command.....</b>	<b>14</b>
<b>6.23. Image1 Command .....</b>	<b>14</b>
<b>6.24. Image2 Command .....</b>	<b>14</b>
<b>6.25. Image3 Command .....</b>	<b>14</b>
<b>6.26. Image4 Command .....</b>	<b>14</b>
<b>6.27. Image Blackboard (Green) Command .....</b>	<b>14</b>
<b>6.28. Image Dynamic Command.....</b>	<b>15</b>
<b>6.29. MENU ON Command .....</b>	<b>15</b>
<b>6.30. MENU OFF Command.....</b>	<b>15</b>
<b>6.31. DISPLAY CLEAR Command.....</b>	<b>15</b>

6.32.	<b>BRIGHTNESS + Command</b> .....	15
6.33.	<b>BRIGHTNESS – Command</b> .....	15
6.34.	<b>IMAGE (Toggle) Command</b> .....	16
6.35.	<b>Direct on Setting Command</b> .....	16
6.36.	<b>Direct on Cancel Command</b> .....	16
6.37.	<b>Power Management Ready Command</b> .....	16
6.38.	<b>Power Management OFF Command</b> .....	16
6.39.	<b>Power Management Shut down Command</b> .....	16
6.40.	<b>D.ZOOM + Command</b> .....	17
6.41.	<b>D.ZOOM – Command</b> .....	17
6.42.	<b>S-Video Command</b> .....	17
6.43.	<b>Image Colorboard Command</b> .....	17
6.44.	<b>POINTER RIGHT Command</b> .....	17
6.45.	<b>POINTER LEFT Command</b> .....	17
6.46.	<b>POINTER UP Command</b> .....	18
6.47.	<b>POINTER DOWN Command</b> .....	18
6.48.	<b>ENTER Command</b> .....	18
6.49.	<b>FREEZE ON Command</b> .....	18
6.50.	<b>FREEZE OFF Command</b> .....	18
6.51.	<b>Computer 1 Analog RGB Command</b> .....	18
6.52.	<b>Computer 1 RGB (SCART) Command</b> .....	19
6.53.	<b>Computer 1 Component Command</b> .....	19
6.54.	<b>AUTO PC ADJ. Command</b> .....	19
6.55.	<b>PRESENTATION TIMER Command</b> .....	19
6.56.	<b>PRESENTATION TIMER (Exit) Command</b> .....	19
6.57.	<b>KEYSTONE Command</b> .....	19
6.58.	<b>KEYSTONE Command</b> .....	20
7.	<b>Status Read Command</b> .....	21
7.1.	<b>Format</b> .....	21
7.2.	<b>Transfer Example</b> .....	21
7.3.	<b>Operation Requirements</b> .....	21
7.4.	<b>Status Read Command</b> .....	22
7.5.	<b>Input Mode Read Command</b> .....	24
7.6.	<b>Lamp Time Read Command</b> .....	24
7.7.	<b>Setting Read Command</b> .....	24
7.8.	<b>Temp Read Command</b> .....	24
7.9.	<b>Lamp Mode Read Command</b> .....	25

## 1. Overview

- 1.1. These specifications define projector control commands for PLC-WL2500 / WL2501.
- 1.2. The projector control commands are used to remotely control a projector through RS-232C from a computer.

## 2. Serial Interface Specifications

### 2.1. Transfer Specifications

Item	Specifications
Synchronous system	Asynchronous
Transmission Speed	9600 / 19200
Data Length	8 bit
Parity	N/A
Stop Bit	1
Flow Control	N/A

- 1) Transmission speed: initial setting value is 19200.
- 2) Transmission speed can be changed in service mode.

### 2.2. Connection

Dedicated serial cable must be used for connection to a computer and a projector.

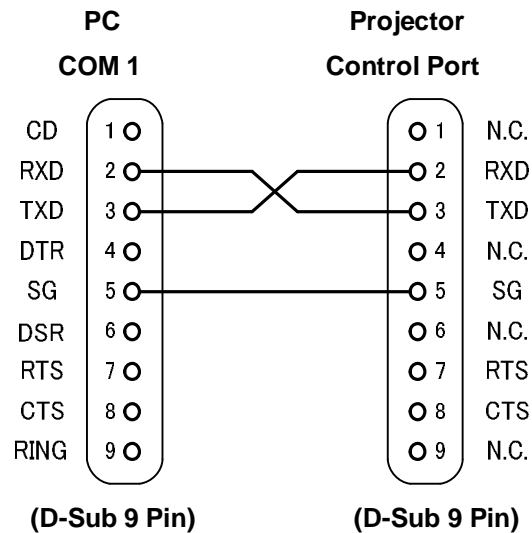

### 3. Notes for Communication

1. The projector control command is defined as one command/one line that starts with "C" and ends with carriage return (0x0D).
2. There are two types of Commands: Functional Execution Commands and Status Read Commands.

Example of Functional Execution Command: "C05" [CR]

Example of Status Read Command: "CR0" [CR]

3. When it takes more than one second to receive one command, it does not operate.  
The information of buffer is cleared when it takes more than one second to receive carriage return (0x0D) after the projector receives the first data "C".

4. For Command pipelining, wait for the interval of 100ms after receiving a response.

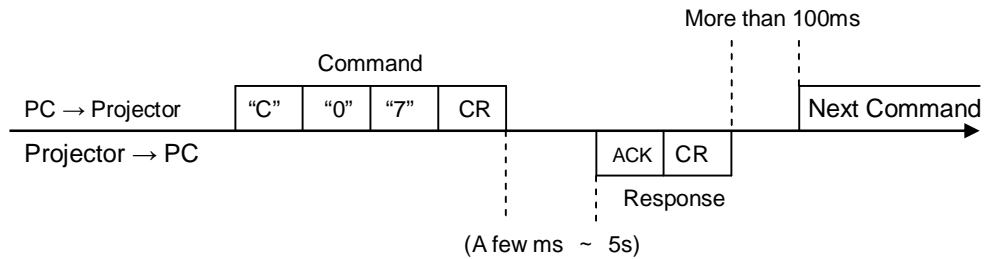

- 4.1. When a command is issued before receiving a response, the function is not executed properly.
- 4.2. Except for when there is no Response for more than 5 seconds.
5. It takes about 5 seconds for internal initialization after plugging in AC power. During this time, it cannot process commands. Do not issue any command.
6. The number of characters of response to Status Read Commands depends on commands.  
Please see [7. Status Read Commands].
7. Characters for commands must be Capital (A - Z).

## 4. Functional Execution Command Table

Command	Item	Command	Item
C00	POWER ON	C20	BRIGHTNESS +
C01	POWER OFF (Quick Power OFF)	C21	BRIGHTNESS -
C02	POWER OFF	C22	-----
C03	-----	C23	-----
C04	HDMI	C24	-----
C05	Computer 1	C25	-----
C06	Computer 2	C26	-----
C07	Video	C27	IMAGE (Toggle)
C08	-----	C28	Direct on Enable
C09	VOLUME +	C29	Direct on Disable
C0A	VOLUME -	C2A	Power Management Ready
C0B	AUDIO MUTE ON	C2B	Power Management OFF
C0C	AUDIO MUTE OFF	C2C	-----
C0D	VIDEO MUTE ON	C2D	-----
C0E	VIDEO MUTE OFF	C2E	Power Management Shut down
C0F	Screen Normal size (4:3)	C2F	-----
C10	Screen Full size	C30	D.ZOOM +
C11	Image Standard	C31	D.ZOOM -
C12	Image Real	C32	-----
C13	Image Cinema	C33	-----
C14	Image 1	C34	S-video
C15	Image 2	C35	-----
C16	Image 3	C36	-----
C17	Image 4	C37	-----
C18	Image Blackboard	C38	-----
C19	Image Dynamic	C39	Image Colorboard
C1A	-----	C3A	POINTER RIGHT
C1B	-----	C3B	POINTER LEFT
C1C	MENU ON	C3C	POINTER UP
C1D	MENU OFF	C3D	POINTER DOWN
C1E	DISPLAY CLEAR	C3E	-----
C1F	-----	C3F	ENTER

----- means no function.

Command	Item	Command	Item
C40	-----	C80	-----
C41	-----	C81	-----
C42	-----	C82	-----
C43	FREEZE ON	C83	-----
C44	FREEZE OFF	C84	-----
C45	-----	C85	-----
C46	-----	C86	-----
C47	-----	C87	-----
C48	-----	C88	-----
C49	-----	C89	Auto PC ADJ.
C4A	-----	C8A	PRESENTATION TIMER
C4B	-----	C8B	PRESENTATION TIMER(EXIT)
C4C	-----	C8C	-----
C4D	-----	C8D	-----
C4E	-----	C8E	KEYSTONE ↑
C4F	-----	C8F	KEYSTONE ↓
C50	Computer 1 Analog RGB	C90	-----
C51	Computer 1 RGB (Scart)	C91	-----
C52	-----	C92	-----
C53	-----	C93	-----
C54	Computer 1 Component	C94	-----
C55	-----	C95	-----
C56	-----	C96	-----
C57	-----	C97	-----
C58	-----	C98	-----
C59	-----	C99	-----
C5A	-----	C9A	-----

----- means no function.

**5. Status Read Command Table**

Command	Item	Memo
CR0	Status Read	
CR1	Input Mode Read	
CR2	-----	
CR3	(Corresponding) Lamp Time Read	
CR4	Setting Read	
CR5	-----	
CR6	Temp Read	
CR7	Lamp Mode Read	

----- means no function.



## 6. Functional Execution Command

### 6.1. Format

6.1.1 PC issues a command in format as below.

“C” **COMMAND** [CR]

Command: two characters (See Basic Functional Execution Command Table)

A projector changes received data to decode and returns a result after being ready to receive next command.

**[ACK][CR]**: (0x06, 0x0D) When received Functional Execution Commands.

6.1.2 “?” [CR]: When the received data cannot be decoded.

### 6.2. Command Pipelining

When some functions need the command pipelining, the performance is the same as that of the remote control;

6.2.1. System: issues any command every 100 ms.

6.2.2. When receiving the appropriate command, the function is executed for 120 ms from the moment.

6.2.3. When receiving the same command continuously within 120 ms, the function is executed for another 120 ms from the moment.

6.2.4. When there is no incoming command after 120 ms, the execution of pipelining is stopped.

6.2.5. When the projector receives other incoming commands within 120ms, the execution of pipelining is stopped.

### 6.3. Transfer Example

Switch the projector to video mode with Basic Command.

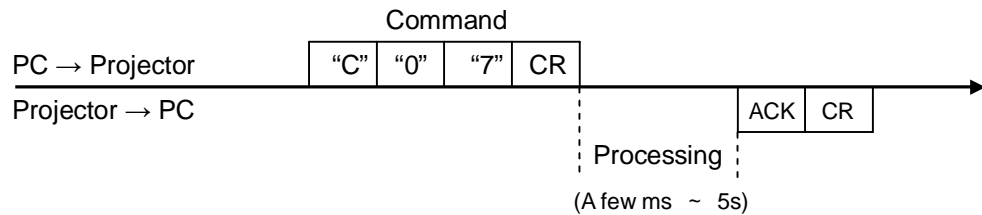

## 6.4. Operation Requirements

1) When the projector's status is any of below, Functional Execution Commands are limited.

Projector Status	Available Functional Execution Commands
In standby status	C00:POWER ON
Countdown in process	C00:POWER ON → Countdown is terminated C01:POWER OFF C02:POWER OFF → Countdown is terminated
Cooling Down in process	NONE (No Execution)
Cooling Down due to Abnormal Temperature	NONE (No Execution)
Abnormal Temperature Status	NONE (No Execution)
Abnormal Power Status	NONE (No Execution)
Power Save / Cooling Down in process	NONE (No Execution)
Power Save Status	C00:POWER ON C01:POWER OFF
Input search : On1/On2 setting	Although transmit Input source commands, Input search does no operate.

Note) When the status is as above, even if the projector receives other commands,

it returns **[ACK] [CR]**.

2) Functional Execution Commands are invalid when Eco mode is selected in Standby mode of Setting menu and projector is in standby.

**6.5. POWER ON Command**

Command	"C00" [CR]	
Detail	Power ON When already Power is ON, nothing is done. When sending this command during processing Countdown, Countdown is terminated.	
Response	Acceptable	[ACK] [CR]
	Unacceptable	" ? "[CR]

**6.6. POWER OFF Command (Quick Power OFF)**

Command	"C01" [CR]	
Detail	Power OFF (Standby) When Power is OFF with ON/STAND-BY button of the projector and the remote control, "Power OFF?" is displayed. However, as soon as this command is sent, Quick Power OFF is executed.	
Response	Acceptable	[ACK] [CR]
	Unacceptable	" ? "[CR]

**6.7. POWER OFF Command**

Command	"C02" [CR]	
Detail	Power OFF (Standby). The command operates the same Power OFF function as ON/STAND-BY button of the projector and the remote control. Once this command is sent, "Power OFF?" is displayed. If this command is sent again while it is displayed, Power OFF is executed. When sending this command during Countdown, Countdown is terminated.	
Response	Acceptable	[ACK] [CR]
	Unacceptable	" ? "[CR]

**6.8. HDMI Command**

Command	"C04" [CR]	
Detail	Select HDMI Input Although projector returns "OK", Input search is not executed with this command while Input search is set to On1/On2.	
Response	Acceptable	[ACK] [CR]
	Unacceptable	" ? "[CR]

**6.9. Computer 1 Command**

Command	"C05" [CR]	
Detail	Select Computer 1 Input Although projector returns "OK", Input search is not executed with this command while Input search is set to On1/On2.	
Response	Acceptable	[ACK] [CR]
	Unacceptable	" ? "[CR]

### 6.10. Computer 2 Command

Command	"C06" [CR]	
Detail	Select Computer2 Input Although projector returns "OK", Input search is not executed with this command while Input search is set to On1/On2. Note) When "Monitor out" is selected in Terminal menu, projector returns "OK" and displays "Monitor out" on the screen by receiving this command.	
Response	Acceptable	[ACK] [CR]
	Unacceptable	" ? "[CR]

### 6.11. Video Command

Command	"C07" [CR]	
Detail	Select Video Input Although projector returns "OK", Input search is not executed with this command while Input search is set to On1/On2.	
Response	Acceptable	[ACK] [CR]
	Unacceptable	" ? "[CR]

### 6.12. VOLUME + Command

Command	"C09" [CR]	
Detail	Volume Up. This command operates the same way as "VOLUME+" button of the projector and the remote control.	
Response	Acceptable	[ACK] [CR]
	Unacceptable	" ? "[CR]

### 6.13. VOLUME – Command

Command	"C0A" [CR]	
Detail	Volume Down This command operates the same way as "VOLUME-" button of the projector and the remote control.	
Response	Acceptable	[ACK] [CR]
	Unacceptable	" ? "[CR]

### 6.14. AUDIO MUTE ON Command

Command	"C0B" [CR]	
Detail	Sound Mute ON. This command works the same as "MUTE" button of the remote control for Mute ON, but does not work for Mute OFF.	
Response	Acceptable	[ACK] [CR]
	Unacceptable	" ? "[CR]

**6.15. AUDIO MUTE OFF Command**

Command	"C0C" [CR]	
Detail	Sound Mute OFF. This command works the same as "MUTE" button of the remote control for Mute OFF, but does not work for Mute ON.	
Response	Acceptable	[ACK] [CR]
	Unacceptable	" ? "[CR]

**6.16. VIDEO MUTE ON Command**

Command	"C0D"[CR]	
Detail	Video Mute ON. This command works the same as "NO SHOW" button of the remote control for No Show ON, but does not work for No Show OFF.	
Response	Acceptable	[ACK] [CR]
	Unacceptable	" ? "[CR]

**6.17. VIDEO MUTE OFF Command**

Command	"C0E" [CR]	
Detail	Video Mute OFF. This command works the same as "NO SHOW" button of remote control for No Show OFF, but does not work for No Show ON.	
Response	Acceptable	[ACK] [CR]
	Unacceptable	" ? "[CR]

**6.18. Screen Normal size Command**

Command	"C0F" [CR]	
Detail	Set screen mode to Normal. This command is invalid while D.Zoom is in operation.	
Response	Acceptable	[ACK] [CR]
	Unacceptable	" ? "[CR]

**6.19. Screen Full size Command**

Command	"C10" [CR]	
Detail	Set screen mode to Full. This command is valid though D.Zoom is in operation.	
Response	Acceptable	[ACK] [CR]
	Unacceptable	" ? "[CR]

**6.20. Image Standard Command**

Command	"C11" [CR]	
Detail	Set image to Standard mode.	
Response	Acceptable	[ACK] [CR]
	Unacceptable	" ? "[CR]

**6.21. Image Real Command**

Command	"C12" [CR]	
Detail	Set image to Real mode.	
Response	Acceptable	[ACK] [CR]
	Unacceptable	" ? "[CR]

**6.22. Image Cinema Command**

Command	"C13" [CR]	
Detail	Set image to Cinema mode.	
Response	Acceptable	[ACK] [CR]
	Unacceptable	" ? "[CR]

**6.23. Image1 Command**

Command	"C14" [CR]	
Detail	Set image to Image1 mode.	
Response	Acceptable	[ACK] [CR]
	Unacceptable	" ? "[CR]

**6.24. Image2 Command**

Command	"C15" [CR]	
Detail	Set image to Image2 mode.	
Response	Acceptable	[ACK] [CR]
	Unacceptable	" ? "[CR]

**6.25. Image3 Command**

Command	"C16" [CR]	
Detail	Set image to Image3 mode.	
Response	Acceptable	[ACK] [CR]
	Unacceptable	" ? "[CR]

**6.26. Image4 Command**

Command	"C17" [CR]	
Detail	Set image to Image4 mode.	
Response	Acceptable	[ACK] [CR]
	Unacceptable	" ? "[CR]

**6.27. Image Blackboard (Green) Command**

Command	"C18" [CR]	
Detail	Set image to Blackboard (Green) mode.	
Response	Acceptable	[ACK] [CR]
	Unacceptable	" ? "[CR]

**6.28. Image Dynamic Command**

Command	"C19" [CR]	
Detail	Set image to Dynamic mode.	
Response	Acceptable	[ACK] [CR]
	Unacceptable	" ? "[CR]

**6.29. MENU ON Command**

Command	"C1C" [CR]	
Detail	Display On-Screen Display Menu.	
Response	Acceptable	[ACK] [CR]
	Unacceptable	" ? "[CR]

**6.30. MENU OFF Command**

Command	"C1D" [CR]	
Detail	Hide On-Screen Display Menu.	
Response	Acceptable	[ACK] [CR]
	Unacceptable	" ? "[CR]

**6.31. DISPLAY CLEAR Command**

Command	"C1E" [CR]	
Detail	Hide On-Screen Display. Hide On-Screen Display unconditionally.	
Response	Acceptable	[ACK] [CR]
	Unacceptable	" ? "[CR]

**6.32. BRIGHTNESS + Command**

Command	"C20" [CR]	
Detail	Brightness of User Control +1.	
Response	Acceptable	[ACK] [CR]
	Unacceptable	" ? "[CR]

**6.33. BRIGHTNESS – Command**

Command	"C21" [CR]	
Detail	Brightness of User Control –1.	
Response	Acceptable	[ACK] [CR]
	Unacceptable	" ? "[CR]

### 6.34. IMAGE (Toggle) Command

Command	"C27"[CR]	
Detail	Switch Image Setting status. This command works the same as "IMAGE" button of the remote control.	
Response	Acceptable	[ACK] [CR]
	Unacceptable	" ? "[CR]

### 6.35. Direct on Setting Command

Command	"C28" [CR]	
Detail	Enable Direct on. This status is stored in EEPROM and retained regardless of Power OFF/ON.	
Response	Acceptable	[ACK] [CR]
	Unacceptable	" ? "[CR]

### 6.36. Direct on Cancel Command

Command	"C29" [CR]	
Detail	Disable Direct on. This status is stored in EEPROM and retained regardless of Power OFF/ON.	
Response	Acceptable	[ACK] [CR]
	Unacceptable	" ? "[CR]

### 6.37. Power Management Ready Command

Command	"C2A" [CR]	
Detail	Set Power Management to Ready mode. This status is stored in EEPROM and retained regardless of Power ON/OFF.	
Response	Acceptable	[ACK] [CR]
	Unacceptable	" ? "[CR]

### 6.38. Power Management OFF Command

Command	"C2B" [CR]	
Detail	Set Power Management to OFF mode. This status is stored in EEPROM and retained regardless of Power ON/OFF.	
Response	Acceptable	[ACK] [CR]
	Unacceptable	" ? "[CR]

### 6.39. Power Management Shut down Command

Command	"C2E" [CR]	
Detail	Set Power Management to Shut down mode. This status is stored in EEPROM and retained regardless of Power OFF/ON.	
Response	Acceptable	[ACK] [CR]
	Unacceptable	" ? "[CR]



**6.40. D.ZOOM + Command**

Command	"C30" [CR]	
Detail	Enter Digital Zoom mode and expand image size. This command works the same as "D.ZOOM ▲" button of the remote control.	
Response	Acceptable	[ACK] [CR]
	Unacceptable	" ? "[CR]

**6.41. D.ZOOM – Command**

Command	"C31" [CR]	
Detail	Enter Digital Zoom mode and reduce image size. This command works the same as "D.ZOOM ▼" button of the remote control.	
Response	Acceptable	[ACK] [CR]
	Unacceptable	" ? "[CR]

**6.42. S-Video Command**

Command	"C34" [CR]	
Detail	Select S-Video input. Although projector returns "OK", Input search is not executed with this command while Input search is set to On1/On2.	
Response	Acceptable	[ACK] [CR]
	Unacceptable	" ? "[CR]

**6.43. Image Colorboard Command**

Command	"C39" [CR]	
Detail	Set image to Colorboard mode.	
Response	Acceptable	[ACK] [CR]
	Unacceptable	" ? "[CR]

**6.44. POINTER RIGHT Command**

Command	"C3A" [CR]	
Detail	Move the Pointer of On-Screen Display Menu to the right. This command works differently from the pointer ">" of the projector and the remote control, and has no function of Volume +.	
Response	Acceptable	[ACK] [CR]
	Unacceptable	" ? "[CR]

**6.45. POINTER LEFT Command**

Command	"C3B" [CR]	
Detail	Move the Pointer of On-Screen Display Menu to the left. This command works differently from the pointer "<" of the projector and the remote control, and has no function of Volume +.	
Response	Acceptable	[ACK] [CR]
	Unacceptable	" ? "[CR]

**6.46. POINTER UP Command**

Command	"C3C" [CR]	
Detail	Move up the Pointer of On-Screen Display Menu. This command works the same as the pointer "▲" of the projector and the remote control.	
Response	Acceptable	[ACK] [CR]
	Unacceptable	" ? "[CR]

**6.47. POINTER DOWN Command**

Command	"C3D" [CR]	
Detail	Move down the Pointer of On-Screen Display Menu. This command works the same as the pointer "▼" of the projector and the remote control.	
Response	Acceptable	[ACK] [CR]
	Unacceptable	" ? "[CR]

**6.48. ENTER Command**

Command	"C3F" [CR]	
Detail	This command works the same as "SELECT" button of the projector and the remote control.	
Response	Acceptable	[ACK] [CR]
	Unacceptable	" ? "[CR]

**6.49. FREEZE ON Command**

Command	"C43" [CR]	
Detail	Freeze on-screen image. This command works the same as "FREEZE" button of the remote control for Freeze ON, but does not work for Freeze OFF.	
Response	Acceptable	[ACK] [CR]
	Unacceptable	" ? "[CR]

**6.50. FREEZE OFF Command**

Command	"C44" [CR]	
Detail	Cancel Freeze mode. This command works the same as "FREEZE" button of the remote control for Freeze OFF, but does not work for Freeze ON.	
Response	Acceptable	[ACK] [CR]
	Unacceptable	" ? "[CR]

**6.51. Computer 1 Analog RGB Command**

Command	"C50" [CR]	
Detail	Select Analog RGB in Computer 1 input. Although projector returns "OK", Input search is not executed with this command while Input search is set to On1/On2.	
Response	Acceptable	[ACK] [CR]
	Unacceptable	" ? "[CR]

**6.52. Computer 1 RGB (SCART) Command**

Command	"C51"[CR]	
Detail	Select Scart input in Computer1. Although projector returns "OK", Input search is not executed with this command while Input search is set to On1/On2.	
Response	Acceptable	[ACK] [CR]
	Unacceptable	" ? "[CR]

**6.53. Computer 1 Component Command**

Command	"C54"[CR]	
Detail	Select Component input in Computer1. Although projector returns "OK", Input search is not executed with this command while Input search is set to On1/On2.	
Response	Acceptable	[ACK] [CR]
	Unacceptable	" ? "[CR]

**6.54. AUTO PC ADJ. Command**

Command	"C89" [CR]	
Detail	Execute Auto PC Adj. function. This command works the same as "AUTO PC ADJ." button of the remote control. Sending the command during Auto PC Adj. operation stops the operation. This is the same operation as "AUTO PC" button of the remote control.	
Response	Acceptable	[ACK] [CR]
	Unacceptable	" ? "[CR]

**6.55. PRESENTATION TIMER Command**

Command	"C8A" [CR]	
Detail	Execute Presentation Timer. This command works the same as "P-TIMER" button of the remote control.	
Response	Acceptable	[ACK] [CR]
	Unacceptable	" ? "[CR]

**6.56. PRESENTATION TIMER (Exit) Command**

Command	"C8B" [CR]	
Detail	Exit Presentation Timer menu. This command works the same as holding on the "P-TIMER" button of the remote control	
Response	Acceptable	[ACK] [CR]
	Unacceptable	" ? "[CR]

**6.57. KEYSTONE ↑Command**

Command	"C8E" [CR]	
Detail	Correct keystone distortion by reducing upper part of image.	
Response	Acceptable	[ACK] [CR]
	Unacceptable	" ? "[CR]

**6.58. KEYSTONE ↓Command**

Command	"C8F" [CR]	
Detail	Correct keystone distortion by reducing down part of image.	
Response	Acceptable	[ACK] [CR]
	Unacceptable	" ? "[CR]

## 7. Status Read Command

### 7.1.Format

7.1.1. PC issues commands in format as below;

**"CR" Command [CR]**

Command : 1 character(See Basic Status Read Command Table)

7.1.2. When a projector receives the appropriate command, it returns a character line as the required data.

**Required Data [CR]**

Required Data : A character line(See Basic Status Read Command Table)

7.1.3. When the received data cannot be decoded, the projector returns "?" [CR].

### 7.2.Transfer Example

Get input mode for projector with basic commands

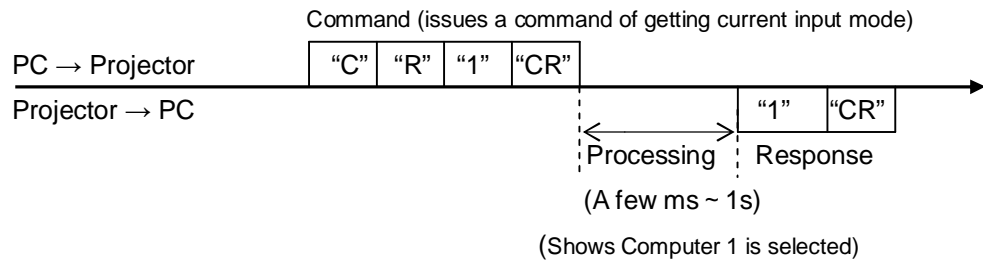

### 7.3.Operation Requirements

Status read Commands are invalid when Eco mode is selected in Standby mode of Setting menu and projector is in standby.

### 7.4. Status Read Command

Command	"CR0" [CR]	
Detail	Get the projector's operating status	
Response	Acceptable	"%1" [CR]
	%1	"00" = Power ON "80" = Standby "40" = Countdown in process "20" = Cooling Down in process "10" = Power Failure "28" = Cooling Down in process due to Temperature Anomaly "88" = Coming back after Temperature Anomaly "24" = Power Save/Cooling Down in process "04" = Power Save "21" = Cooling Down is in process after Power off due to lamp failure "81" = Standby after Cooling Down due to lamp failure
	Unacceptable	"?" [CR]

#### [Details of Response]

##### "00" [CR]

Status: Power ON  
Normal image is on the screen.

##### "80" [CR]

Status: Standby  
When the status is Standby, Status Read Commands are always acceptable, but Functional Execution Commands are not acceptable except POWER ON Command.

##### "40" [CR]

Status: Countdown in process  
When "Display" in Setting Menu is ON and POWER ON is executed, it starts Countdown.  
When "Display" in Setting Menu is OFF, processing Countdown is not executed and the status quickly moves to Power ON.

##### "20" [CR]

Status: Cooling Down in process  
When the status is Power ON, and POWER OFF Command ("C01" [CR]) is executed, it moves to Cooling Down status.  
This status automatically moves to Standby after lamp turns off and the fan spin finishes after about 90 seconds. The fan spin time depends on a model.  
This function is used to cool down the lamps and other optical parts and is quite important for projector's reliability.  
During this time, Functional Execution Commands are invalid.

##### "10" [CR]

Status: Power Failure  
When the power supply voltage inside the projector reaches abnormal status, the projector is automatically turned off. The projector returns "10" [CR], which shows it

moves to Power OFF status due to power failure. Fan also stops unlike Cooling Down status.

**“28” [CR]**

Status: Cooling Down in process due to Temperature Anomaly

When the inside temperature is out of the operating temperature, it automatically starts Cooling Down. Response for this status is “28” [CR].

Even if the temperature decreases during this process, Cooling Down is executed.

**“88” [CR]**

Status: Coming back after temperature anomaly

When the status moves to Standby after Cooling Down due to temperature anomaly, it returns “88” [CR].

This shows that the status turns to Standby because of abnormal temperature.

This status maintains until next operation is done. When Power On is executed, the information of temperature anomaly is canceled and normal operation is executed.

**“24” [CR]**

Status: Processing Power Save / Cooling Down

Power management function in Setting menu works and the status goes to Power Save / Cooling Down.

During this time, Functional Execution Commands are invalid (not executed).

This status moves to Power Save at set hours after the operation of Cooling Down.

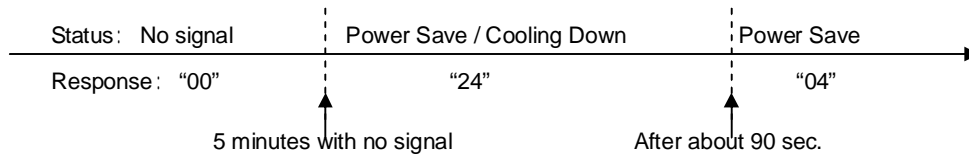

**“04” [CR]**

Status: Power Save

This shows that it moves to Power Save status by Power management function in Setting menu.

**“21” [CR]**

Status: Cooling Down in process after turned off due to lamp failure

When a projector is turned off because of lamp failure, it automatically starts Cooling Down operation, in which the projector returns “21” [CR].

**“81” [CR]**

Status: Standby after Cooling Down due to lamp failure.

This value is returned when Cooling Down operation due to lamp failure has been completed and the status has been moved to Standby. The status is kept until the next operation starts.

### 7.5. Input Mode Read Command

Command	"CR1" [CR]	
Detail	Get the selected Input No.	
Response	Acceptable	"%1" [CR]
	%1	"1" = Computer 1 is selected "2" = Computer 2 is selected "3" = HDMI is selected "4" = Video is selected "5" = S-video is selected
	Unacceptable	"?" [CR]

### 7.6. Lamp Time Read Command

Command	"CR3" [CR]	
Detail	Get the total lamp running hours (Not actual lamp used hour, but Eco mode corresponding value).	
Response	Acceptable	"%1" [CR]
	%1	Shows the time period with 5 digits numbers. Example: "00410"[CR] ... shows 410 hours
	Unacceptable	"?" [CR]

### 7.7. Setting Read Command

Command	"CR4" [CR]	
Detail	Get screen setting status such as Ceiling / Rear.	
Response	Acceptable	"%1" [CR]
	%1	"11"[CR] = Normal Screen Setting "10"[CR] = Picture is top/bottom reversed. (Status: Rear & Ceiling ON) "01"[CR] = Picture is left/right reversed. (Status: Rear ON) "00"[CR] = Picture is top/bottom and left/right reversed. (Status: Ceiling ON)
	Unacceptable	"?" [CR]

### 7.8. Temp Read Command

Command	"CR6" [CR]	
Detail	Get the temperature data inside the projector. With some temperature sensors installed in the projector, it is possible to get all the temperature at once.	
Response	Acceptable	"%1_%2_%3" [CR]
	%1 %2 %3	%1 = Temperature of sensor 1 %2 = Temperature of sensor 2 %3 = Temperature of sensor 3 Temperature data is shown as "00.0". When the temperature goes down to -, the first character becomes "-" instead of a space, like "-05.5" [CR]. When no temperature data can be returned due to hardware problems, the first character becomes "E" like"E00.0" [CR]. When several temperature sensors are equipped, Responses are returned continuously. "_31.5 _ _35.2 _ _33.4"[CR] The first data is sensor 1, then one space, and the data of sensor 2 follows.
	Unacceptable	" ? "[CR]



### 7.9.Lamp Mode Read Command

Command	"CR7" [CR]	
Detail	Get lamp mode status. For 1 lamp projector, get if it is lighting or not.	
Response	Acceptable	"%1" [CR]
	%1	"00" [CR]=Light is out. "01" [CR]=Light is on.
	Unacceptable	" ? "[CR]