



LK990 / L6000

Projector RS232 Command Control

Installation Guide

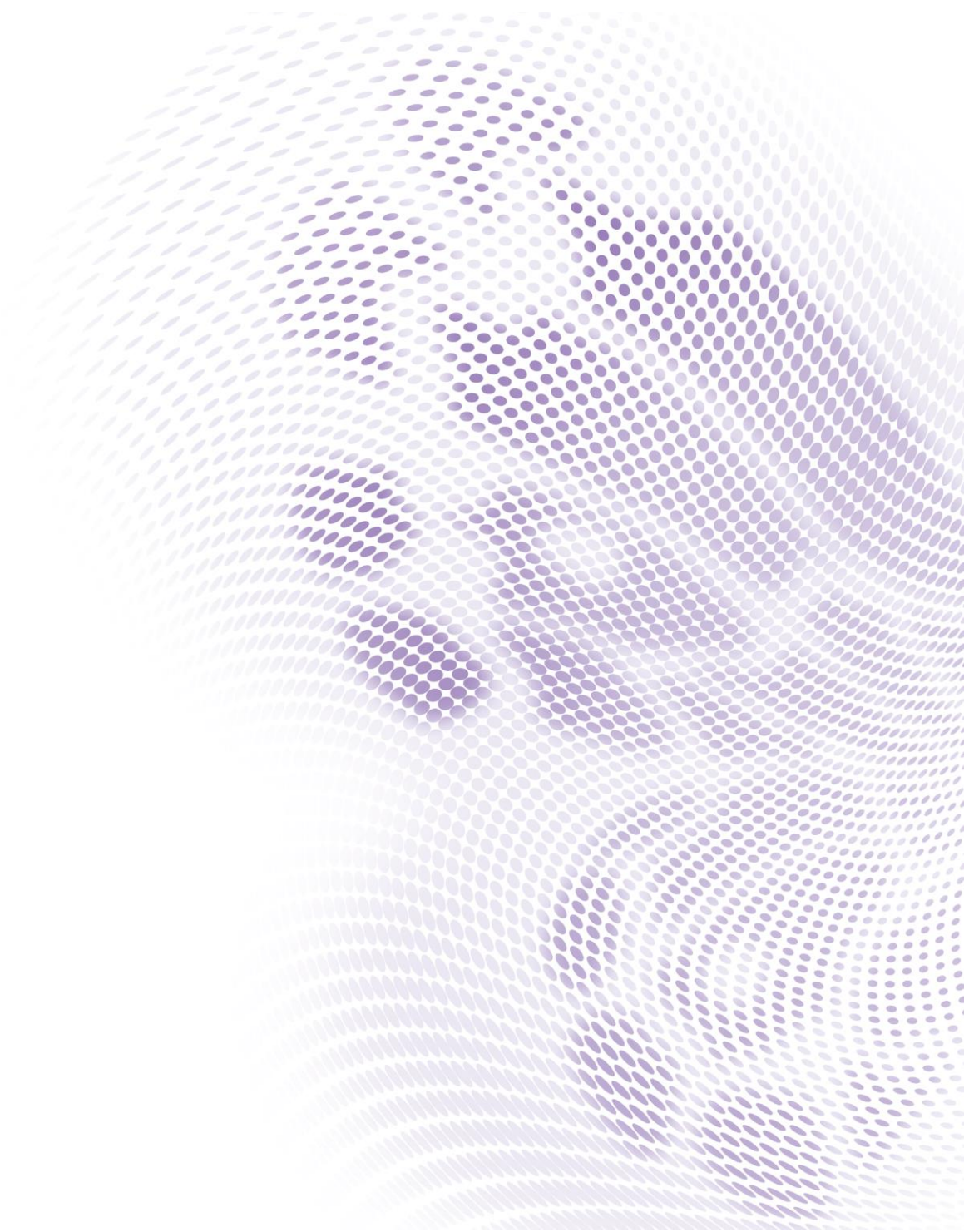

Table of Contents

Introduction	3
Wire arrangement.....	3
RS232 pin assignment.....	3
Connections and communication settings	4
RS232 serial port with a crossover cable	4
Settings	4
RS232 via LAN.....	6
Settings	6
RS232 via HDBaseT.....	6
Settings	6
Command table.....	8

Introduction

The document describes how to control your BenQ projector via RS232 from a computer. Follow the procedures to complete the connection and settings first, and refer to the command table for RS232 commands.



Available functions and commands vary by model. Check the specifications and user manual of the purchased projector for product functions.

Wire arrangement

Wire Arrangement		
P1	Color	P2
1	Black	1
2	Brown	3
3	Red	2
4	Orange	4
5	Yellow	5
6	Green	6
7	Blue	7
8	Purple	8
9	Gray	9
Case	Drain wire	Case

RS232 pin assignment



Pin	Description	Pin	Description
1	NC	2	RXD
3	TXD	4	NC
5	GND	6	NC
7	RTS	8	CTS
9	NC		

Connections and communication settings

Choose one of the connections and set up properly before RS232 control.

RS232 serial port with a crossover cable

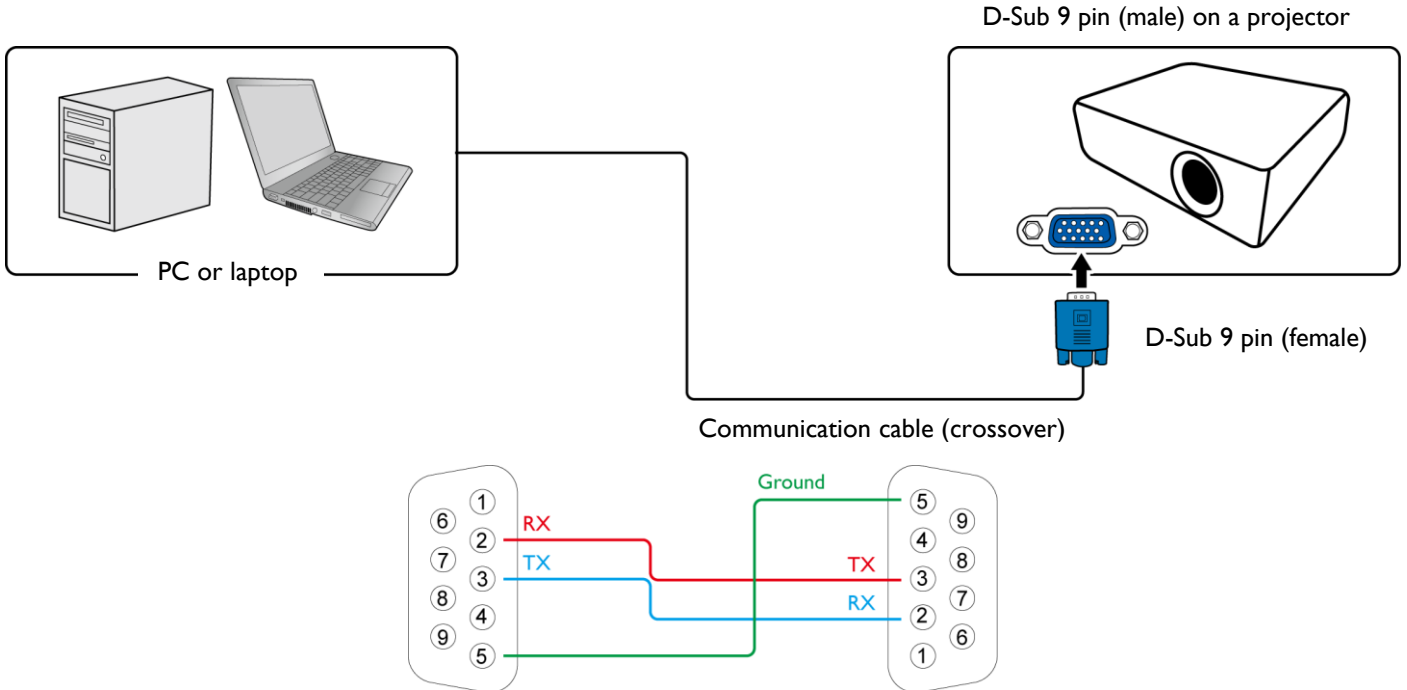

Settings

 On-screen images in this document are for reference only. The screens may vary depending on your Operating System, I/O ports used for connection, and the specifications of the connected projector.

- I. Determine the COM Port name used for the RS232 communications in **Device Manager**.

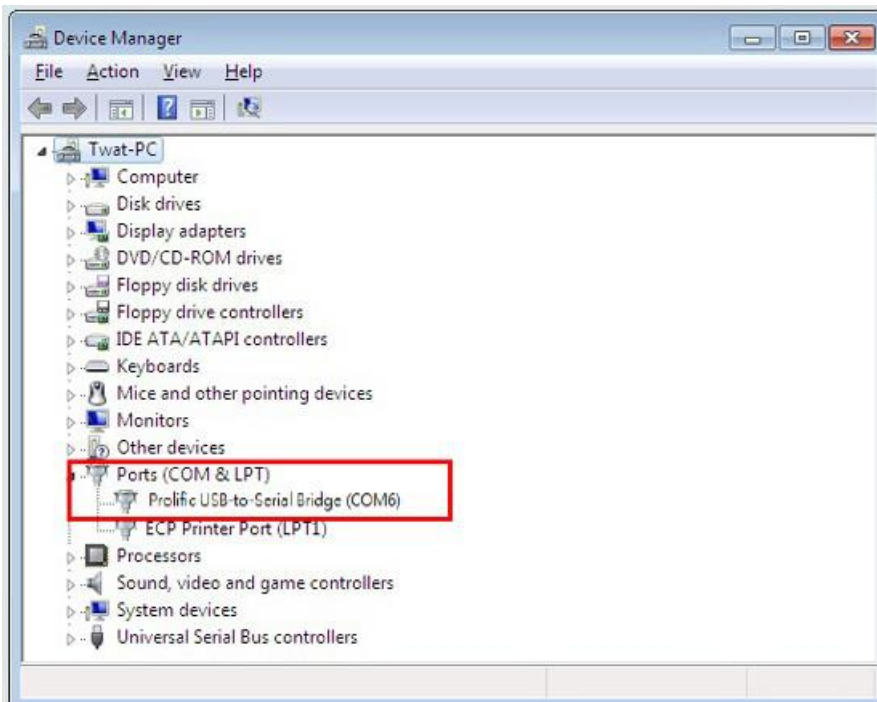

- Choose **Serial** and the corresponding COM port as the communication port. In this given example, COM6 is selected.



- Finish **Serial port setup**.

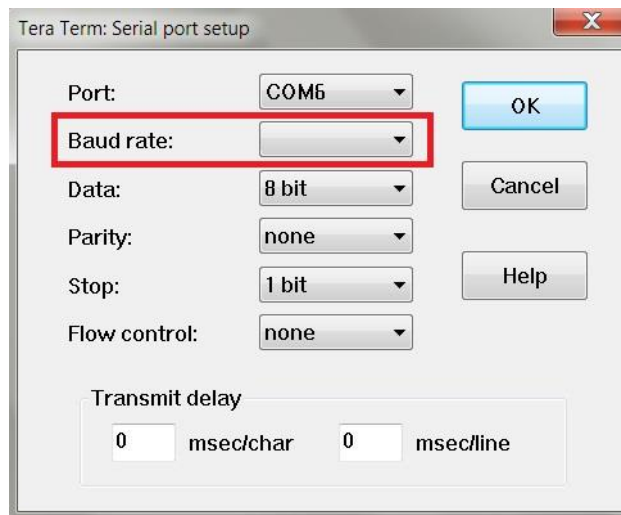

Baud rate	9600 bps  Check the baud rate of the connected projector from its OSD menu.
Data length	8 bit
Parity check	None
Stop bit	1 bit
Flow control	None

RS232 via LAN



Settings

1. Find the Wired LAN IP address of the connected projector from the OSD menu and make sure the projector and the computer are within the same network.
2. Input **8000** in the **TCP port #** field.



RS232 via HDBaseT

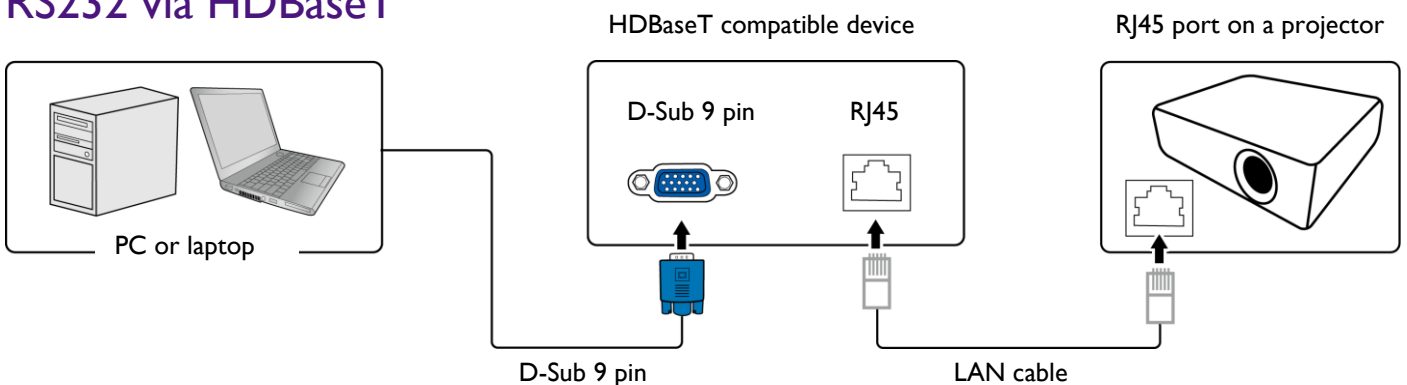

Settings

1. Determine the COM Port name used for the RS232 communications in **Device Manager**.
2. Choose **Serial** and the corresponding COM port as the communication port. In this given example, COM6 is selected.



3. Finish **Serial** port setup.



Baud rate	9600 bps  Check the baud rate of the connected projector from its OSD menu.
Data length	8 bit
Parity check	None
Stop bit	1 bit
Flow control	None

Command table



- Available features differ by projector specification, input sources, settings, etc..
- Commands are working if the standby power is 0.5W or a supported baud rate of the projector is set.
- Uppercase, lowercase, and a mixture of both types of characters are accepted for a command.
- If a command format is illegal, it will echo **Illegal format**.
- If a command with correct format is not valid for the projector model, it will echo **Unsupported item**.
- If a command with correct format cannot be executed under certain condition, it will echo **Block item**.
- If RS232 control is performed via LAN, a command works whether it starts and ends with **<CR>**. All the commands and behaviors are identical with the control through a serial port.

Function	Type	Operation	ASCII	
Power	Write	Power On	<CR>*pow=on#<CR>	Y
	Write	Power off	<CR>*pow=off#<CR>	Y
	Read	Power Status	<CR>*pow=?#<CR>	Y
Source Selection	Write	COMPUTER/YPbPr	<CR>*sour=RGB#<CR>	Y
	Write	COMPUTER 2/YPbPr2	<CR>*sour=RGB2#<CR>	N
	Write	COMPUTER 3/YPbPr3	<CR>*sour=RGB3#<CR>	N
	Write	Component	<CR>*sour=ypr#<CR>	N
	Write	Component2	<CR>*sour=ypr2#<CR>	N
	Write	DVI-A	<CR>*sour=dviA#<CR>	N
	Write	DVI-D	<CR>*sour=dvid#<CR>	N
	Write	HDMI(MHL)	<CR>*sour=hdmi#<CR>	Y
	Write	HDMI 2(MHL2)	<CR>*sour=hdmi2#<CR>	Y
	Write	HDMI 3(MHL3)	<CR>*sour=hdmi3#<CR>	Y
	Write	Composite	<CR>*sour=vid#<CR>	N
	Write	S-Video	<CR>*sour=svid#<CR>	N
	Write	Network	<CR>*sour=network#<CR>	N
	Write	USB Display	<CR>*sour=usbdisplay#<CR>	N
	Write	USB Reader	<CR>*sour=usbreader#<CR>	N
	Write	HDBaseT	<CR>*sour=hdbaset#<CR>	Y
	Write	DisplayPort	<CR>*sour=dp#<CR>	N
	Write	3G-SDI	<CR>*sour=sdi#<CR>	N
Read	Current source	<CR>*sour=?#<CR>	Y	
Audio Control	Write	Mute On	<CR>*mute=on#<CR>	Y
	Write	Mute Off	<CR>*mute=off#<CR>	Y
	Read	Mute Status	<CR>*mute=?#<CR>	Y
	Write	Volume +	<CR>*vol=+#<CR>	Y

	Write	Volume -	<CR>*vol=-#<CR>	Y
	Write	Volume level for customer	<CR>*vol=value#<CR>	Y
	Read	Volume Status	<CR>*vol=?#<CR>	Y
	Write	Mic.Volume +	<CR>*micvol=+#<CR>	N
	Write	Mic.Volume -	<CR>*micvol=-#<CR>	N
	Read	Mic.Volume Status	<CR>*micvol=?#<CR>	N
Audio source select	Write	Audio pass Through off	<CR>*audiosour=off#<CR>	N
	Write	Audio-Computer1	<CR>*audiosour=RGB#<CR>	N
	Write	Audio-Computer2	<CR>*audiosour=RGB2#<CR>	N
	Write	Audio-Video/S-Video	<CR>*audiosour=vid#<CR>	N
	Write	Audio-Component	<CR>*audiosour=ypr#<CR>	N
	Write	Audio-HDMI	<CR>*audiosour=hdmi#<CR>	N
	Write	Audio-HDMI2	<CR>*audiosour=hdmi2#<CR>	N
	Read	Audio pass Status	<CR>*audiosour=?#<CR>	N
Picture Mode	Write	Dynamic	<CR>*appmod=dynamic#<CR>	N
	Write	Presentation	<CR>*appmod=preset#<CR>	Y
	Write	sRGB	<CR>*appmod=srgb#<CR>	N
	Write	Bright	<CR>*appmod=bright#<CR>	Y
	Write	Living Room	<CR>*appmod=livingroom#<CR>	N
	Write	Game	<CR>*appmod=game#<CR>	N
	Write	Cinema	<CR>*appmod=cine#<CR>	Y
	Write	Standard/Vivid	<CR>*appmod=std#<CR>	N
	Write	Football	<CR>*appmod=football#<CR>	N
	Write	Football Bright	<CR>*appmod=footballbt#<CR>	N
	Write	DICOM	<CR>*appmod=dicom#<CR>	Y
	Write	THX	<CR>*appmod=thx#<CR>	N
	Write	Silence mode	<CR>*appmod=silence#<CR>	Y
	Write	DCI-P3 mode	<CR>*appmod=dci-p3#<CR>	N
	Write	Vivid	<CR>*appmod=vivid#<CR>	Y
	Write	Infographic	<CR>*appmod=infographic#<CR>	N
	Write	User1	<CR>*appmod=user1#<CR>	Y
	Write	User2	<CR>*appmod=user2#<CR>	N
	Write	User3	<CR>*appmod=user3#<CR>	N
	Write	ISF Day	<CR>*appmod=isfday#<CR>	N
	Write	ISF Night	<CR>*appmod=isfnight#<CR>	N
	Write	3D	<CR>*appmod=threed#<CR>	N
	Read	Picture Mode	<CR>*appmod=?#<CR>	Y
Picture Setting	Write	Contrast +	<CR>*con=+#<CR>	Y

Write	Contrast -	<CR>*con=-#<CR>	Y
Read	Contrast value	<CR>*con=?#<CR>	Y
Write	Brightness +	<CR>*bri=+#<CR>	Y
Write	Brightness -	<CR>*bri=-#<CR>	Y
Read	Brightness value	<CR>*bri=?#<CR>	Y
Write	Color +	<CR>*color=+#<CR>	Y
Write	Color -	<CR>*color=-#<CR>	Y
Read	Color value	<CR>*color=?#<CR>	Y
Write	Sharpness +	<CR>*sharp=+#<CR>	Y
Write	Sharpness -	<CR>*sharp=-#<CR>	Y
Read	Sharpness value	<CR>*sharp=?#<CR>	Y
Write	Flesh Tone +	<CR>*fleshtone=+#<CR>	Y
Write	Flesh Tone -	<CR>*fleshtone=-#<CR>	Y
Read	Flesh Tone value	<CR>*fleshtone=?#<CR>	Y
Write	Color Temperature-Warmer	<CR>*ct=warm#<CR>	N
Write	Color Temperature-Warm	<CR>*ct=warm#<CR>	Y
Write	Color Temperature-Normal	<CR>*ct=normal#<CR>	Y
Write	Color Temperature-Cool	<CR>*ct=cool#<CR>	Y
Write	Color Temperature-Cooler	<CR>*ct=cooler#<CR>	N
Write	Color Temperature-lamp native	<CR>*ct=native#<CR>	Y
Read	Color Temperature Status	<CR>*ct=?#<CR>	Y
Write	Aspect 4:3	<CR>*asp=4:3#<CR>	Y
Write	Aspect 16:6	<CR>*asp=16:6#<CR>	N
Write	Aspect 16:9	<CR>*asp=16:9#<CR>	Y
Write	Aspect 16:10	<CR>*asp=16:10#<CR>	Y
Write	Aspect Auto	<CR>*asp=AUTO#<CR>	Y
Write	Aspect Real	<CR>*asp=REAL#<CR>	Y
Write	Aspect Letterbox	<CR>*asp=LBOX#<CR>	N
Write	Aspect Wide	<CR>*asp=WIDE#<CR>	N
Write	Aspect Anamorphic	<CR>*asp=ANAM#<CR>	N
Write	Aspect 2.35 I	<CR>*asp=2.35#<CR>	Y
Write	Aspect Anamorphic 2.35	<CR>*asp=ANAM2.35#<CR>	Y
Write	Aspect Anamorphic 16:9	<CR>*asp=ANAM16:9#<CR>	Y
Read	Aspect Status	<CR>*asp=?#<CR>	Y
Write	Digital Zoom In	<CR>*zoomI#<CR>	N

	Write	Digital Zoom out	<CR>*zoomO#<CR>	N
	Write	Auto	<CR>*auto#<CR>	Y
	Write	Lamp Custom Value+	<CR>*lampcustom=+<CR>	Y
	Write	Lamp Custom Value-	<CR>*lampcustom=-<CR>	Y
	Read	Lamp Custom Value	<CR>*lampcustom=?<CR>	Y
	Write	Brilliant color on	<CR>*BC=on#<CR>	Y
	Write	Brilliant color off	<CR>*BC=off#<CR>	Y
	Read	Brilliant color status	<CR>*BC=?#<CR>	Y
Operation Settings	Write	Projector Position-Front Table	<CR>*pp=FT#<CR>	Y
	Write	Projector Position-Rear Table	<CR>*pp=RE#<CR>	Y
	Write	Projector Position-Rear Ceiling	<CR>*pp=RC#<CR>	Y
	Write	Projector Position-Front Ceiling	<CR>*pp=FC#<CR>	Y
	Write	Quick cooling on	<CR>*qcool=on<CR>	N
	Write	Quick cooling off	<CR>*qcool=off<CR>	N
	Read	Quick cooling status	<CR>*qcool=?<CR>	N
	Write	Quick auto search	<CR>*QAS=on#<CR>	Y
	Write	Quick auto search	<CR>*QAS=off#<CR>	Y
	Read	Quick auto search status	<CR>*QAS=?#<CR>	Y
	Read	Projector Position Status	<CR>*pp=?#<CR>	Y
	Write	Direct Power On-on	<CR>*directpower=on#<CR>	Y
	Write	Direct Power On-off	<CR>*directpower=off#<CR>	Y
	Read	Direct Power On-Status	<CR>*directpower=?#<CR>	Y
	Write	Signal Power On-on	<CR>*autopower=on#<CR>	Y
	Write	Signal Power On-off	<CR>*autopower=off#<CR>	Y
	Read	Signal Power On-Status	<CR>*autopower=?#<CR>	Y
	Write	Standby Settings-Network on	<CR>*standbynet=on#<CR>	Y
	Write	Standby Settings-Network off	<CR>*standbynet=off#<CR>	Y
	Read	Standby Settings-Network Status	<CR>*standbynet=?#<CR>	Y
	Write	Standby Settings-Microphone on	<CR>*standbymic=on#<CR>	N
	Write	Standby Settings-Microphone off	<CR>*standbymic=off#<CR>	N

		Settings-Microphone off		
	Read	Standby Settings-Microphone Status	<CR>*standbymic=?#<CR>	N
	Write	Standby Settings-Monitor Out on	<CR>*standbymnt=on#<CR>	N
	Write	Standby Settings-Monitor Out off	<CR>*standbymnt=off#<CR>	N
	Read	Standby Settings-Monitor Out Status	<CR>*standbymnt=?#<CR>	N
Baud Rate	Write	2400	<CR>*baud=2400#<CR>	N
	Write	4800	<CR>*baud=4800#<CR>	N
	Write	9600	<CR>*baud=9600#<CR>	N
	Write	14400	<CR>*baud=14400#<CR>	N
	Write	19200	<CR>*baud=19200#<CR>	N
	Write	38400	<CR>*baud=38400#<CR>	N
	Write	57600	<CR>*baud=57600#<CR>	N
	Write	115200	<CR>*baud=115200#<CR>	N
	Read	Current Baud Rate	<CR>*baud=?#<CR>	N
Lamp Control	Read	Lamp	<CR>*ltim=?#<CR>	Y
	Read	Lamp2 Hour	<CR>*ltim2=?#<CR>	N
	Write	Normal mode	<CR>*lampm=lnor#<CR>	Y
	Write	Eco mode	<CR>*lampm=eco#<CR>	Y
	Write	SmartEco mode	<CR>*lampm=seco#<CR>	Y
	Write	SmartEco mode 2	<CR>*lampm=seco2#<CR>	N
	Write	SmartEco mode 3	<CR>*lampm=seco3#<CR>	N
	Write	Dimming mode	<CR>*lampm=dimming#<CR>	Y
	Write	Custom mode	<CR>*lampm=custom#<CR>	Y
	Write	Light level for custom mode	<CR>*lampcustom=value#<CR>	Y
	Read	Light level status for custom mode	<CR>*lampcustom=?#<CR>	Y
	Write(Dual lamp)	Dual Brightest	<CR>* lampm =dualbr#<CR>	N
	Write(Dual lamp)	Dual Reliable	<CR>* lampm =dualre#<CR>	N
	Write(Dual lamp)	Single Alternative	<CR>* lampm =single#<CR>	N
Write(Dual lamp)	Single Alternative Eco	<CR>* lampm =singleeco#<CR>	N	

	lamp)			
	Read	Lamp Mode Status	<CR>*lampm=?#<CR>	Y
Miscellaneous	Read	Model Name	<CR>*modelname=?#<CR>	Y
	Write	Blank On	<CR>*blank=on#<CR>	Y
	Write	Blank Off	<CR>*blank=off#<CR>	Y
	Read	Blank Status	<CR>*blank=?#<CR>	Y
	Write	Freeze On	<CR>*freeze=on#<CR>	N
	Write	Freeze Off	<CR>*freeze=off#<CR>	N
	Read	Freeze Status	<CR>*freeze=?#<CR>	N
	Write	Menu On	<CR>*menu=on#<CR>	Y
	Write	Menu Off	<CR>*menu=off#<CR>	Y
	Write	Up	<CR>*up#<CR>	Y
	Write	Down	<CR>*down#<CR>	Y
	Write	Right	<CR>*right#<CR>	Y
	Write	Left	<CR>*left#<CR>	Y
	Write	Enter	<CR>*enter#<CR>	Y
	Write	3D Sync Off	<CR>*3d=off#<CR>	Y
	Write	3D Auto	<CR>*3d=auto#<CR>	Y
	Write	3D Sync Top Bottom	<CR>*3d=tb#<CR>	Y
	Write	3D Sync Frame Sequential	<CR>*3d=fs#<CR>	Y
	Write	3D Frame packing	<CR>*3d=fp#<CR>	N
	Write	3D Side by side	<CR>*3d=sbs#<CR>	Y
	Write	3D inverter disable	<CR>*3d=da#<CR>	Y
	Write	3D inverter	<CR>*3d=iv#<CR>	Y
	Write	2D to 3D	<CR>*3d=2d3d#<CR>	N
	Write	3D nVIDIA	<CR>*3d=nvidia#<CR>	N
	Read	3D Sync Status	<CR>*3d=?#<CR>	Y
	Write	Remote Receiver-front+rear	<CR>*rr=fr#<CR>	N
	Write	Remote Receiver-front	<CR>*rr=f#<CR>	N
	Write	Remote Receiver-rear	<CR>*rr=r#<CR>	N
	Write	Remote Receiver-top	<CR>*rr=t#<CR>	N
	Write	Remote Receiver-top+front	<CR>*rr=tf#<CR>	N
	Write	Remote Receiver-top+rear	<CR>*rr=tr#<CR>	N
	Read	Remote Receiver Status	<CR>*rr=?#<CR>	N
Write	Instant On-on	<CR>*ins=on#<CR>	N	

	Write	Instant On-off	<CR>*ins=off##<CR>	N
	Read	Instant On Status	<CR>*ins=?##<CR>	N
	Write	Lamp Saver Mode-on	<CR>*lpsaver=on##<CR>	N
	Write	Lamp Saver Mode-off	<CR>*lpsaver=off##<CR>	N
	Read	Lamp Saver Mode Status	<CR>*lpsaver=?##<CR>	N
	Write	Projection Log In Code on	<CR>*prjlogincode=on##<CR>	N
	Write	Projection Log In Code off	<CR>*prjlogincode=off##<CR>	N
	Read	Projection Log In Code Status	<CR>*prjlogincode=?##<CR>	N
	Write	Broadcasting on	<CR>*broadcasting=on##<CR>	N
	Write	Broadcasting off	<CR>*broadcasting=off##<CR>	N
	Read	Broadcasting Status	<CR>*broadcasting=?<CR>	N
	Write	AMX Device Discovery-on	<CR>*amxdd=on##<CR>	Y
	Write	AMX Device Discovery-off	<CR>*amxdd=off##<CR>	Y
	Read	AMX Device Discovery Status	<CR>*amxdd=?##<CR>	Y
	Read	Mac Address	<CR>*macaddr=?##<CR>	Y
	Write	High Altitude mode on	<CR>*Highaltitude=on##<CR>	Y
	Write	High Altitude mode off	<CR>*Highaltitude=off##<CR>	Y
Read	High Altitude mode status	<CR>*Highaltitude=?##<CR>	Y	

BenQ.com

© 2018 BenQ Corporation

All rights reserved. Rights of modification reserved.

Version: 1.01-C