

Installation/Operating Instructions

Micro Projector Lift by Draper

⚠ **Caution:**

- ① Read instructions completely before proceeding.
- ② Follow instructions carefully. Installation contrary to instructions invalidates warranty.
- ③ Do not obstruct operation of Micro Projector Lift with fingers or any object. Serious injury or damage could result.
- ④ It is not uncommon to overheat the motor during initial installation when setting limits. The motor is thermally protected and will stop working until it has cooled to a safe temperature before it will start operating again.
- ⑤ The Micro Projector Lift is designed to accommodate ceiling suspended equipment. Equipment should not be allowed to rest on ceiling closure during operation. (Refer to section titled "Installing Projector.")
- ⑥ Entire bottom of unit must be unobstructed to permit proper operation.
- ⑦ Unit must be installed level (use a carpenter's level).
- ⑧ Maximum lifting capacity 35 lbs.
- ⑨ Unit operates on 110-120V AC 60 Hz. current.

Note: Unit has been thoroughly inspected and tested at factory and found to be operating properly prior to shipment.

Planning

- ① Based on screen location and projector specifications, determine proper position for projector installation.
- ② Confirm that there is adequate space for installation and operation. Minimum clearance above ceiling level varies according to Micro Projector Lift plus height of projector, optional projector mounting bracket, optional ceiling closure, and optional environmental air space rated housing.
- ③ Arrange to provide service access to the unit.

As Soon As Micro Projector Lift Arrives

- ① Open carton and inspect for damage.
- ② Locate the following parts:
 - A. The unit itself;
 - B. Controls;
 - C. Any optional equipment.

Hanging Unit

The Micro Projector Lift is provided with four (4) holes, spaced 18" apart center to center, with $\frac{5}{16}$ " clinch nuts provided for suspending or direct mounting the unit. The unit should be guy wired or blocked to prevent swinging.

All installations should observe the following guidelines:

- ① Installer must ensure that all fasteners and supports are of adequate strength to securely support Micro Projector Lift and projector.
- ② Fastening methods must be suitable for mounting surface, and securely anchored so that vibration or abusive pulling on unit will not weaken installation.
- ③ Bottom of unit must be unobstructed after installation. Sufficient clearance must be allowed below projector or optional ceiling closure.
- ④ Do not use unit to support adjacent ceiling, light fixtures, etc.
- ⑤ Do not complete the ceiling below unit until electrical connections have been completed and unit has been operated successfully.
- ⑥ We recommend that safety cables be attached to the Micro Projector Lift for added security (a sound installation practice with overhead equipment).
- ⑦ When the MPL is to be installed in "other space used for environmental air" the optional environmental air space rated housing must be installed per instructions to isolate the lift from the "other space used for environmental air."

Please Note: MPL must be installed in accordance with the requirements of the Local Building Codes, the Canadian Electrical Code (CEC), CAN/CSA C22.1 and the National Electric Code(NEC), NFPA 70. An appropriate disconnect device shall be provided as part of the building installation.

DRAPER®

411 S. Pearl St., Spiceland, IN 47385 USA ■ 765-987-7999
www.draperinc.com ■ fax 765-987-7142
Copyright © 2008 Draper Inc. Form MicroProjectorLift_Inst08 Printed in U.S.A.

Electrical Connections

Unit operates on 110-120V AC, 60 Hz. current.

The Micro Projector Lift is shipped closed, with a temporary field connection provided in the form of a pigtail temporarily wired to the unit. After hanging the unit, make sure power is off and use this pigtail to temporarily connect the unit to power and to a switch, so the unit can be lowered to allow access inside.

⚠ Caution: Make sure electrical supply has been disconnected before attempting to connect MPL to electricity.

Junction box for field connections is located inside the unit on the left (as seen from front, or non-scissored end). Unit is shipped with internal wiring complete to the junction box. Once the unit has been lowered, turn off power, disconnect temporary pigtail from unit, then complete permanent wiring to electricity and to switches. Wire to connect unit to power supply and to switches should be furnished by installer. Connections should be made in accordance with wiring diagram, and wiring should comply with national and local electrical codes. All operating switches should be "off" before power is connected.

Micro Projector Lift should be operated and checked prior to installing projector and/or optional ceiling closure.

Operation

When unit is first operated, be cautious! If unit fails to operate when the switch is flipped "down", return switch to "off" and recheck electrical connections before proceeding. Cycle unit down and up several times to confirm satisfactory operation.

110v Single Station Control — 3-position up-off-down switch permits operation to be stopped at any point. Factory adjusted limit switches automatically stop Micro Projector Lift when fully down or fully up.

Optional 110v Multiple Station Control—Switches are similar in appearance to 110v Single Station Control. Micro Projector Lift stops when switch is released and may be restarted in either direction. Factory adjusted limit switches stop Micro Projector Lift automatically when up or fully down.

Optional 24v Control — Three-button up-stop-down switches stop at any point desired, operate in any sequence. Factory adjusted limit switches automatically stop Micro Projector Lift when fully up or fully down.

Optional Infrared or Radio Frequency Remote Control—If ordered, a three-button transmitter is provided, with "up", "down", and "stop" buttons. Unit starts up or down when appropriate button is pressed, and may be stopped by pressing "off" button. Factory set limit switches stop unit automatically when projector is in "show" position. Multiple Station Control required for this option.

Optional RS232/Ethernet—Serial communication and network communication optionally available with wall switches, RF or IR remote.

Optional Key Operated Switching — Two kinds of key-operated switches are optionally available with this unit. ① The key-operated power supply switch controls power to the MPL and switches. When it is "off", the switches will not operate lift. Key may be removed from the switch in either "on" or "off" position. ② A three-position key switch permits the MPL to be operated directly by key. In this case, the screen's operator must always have a key.

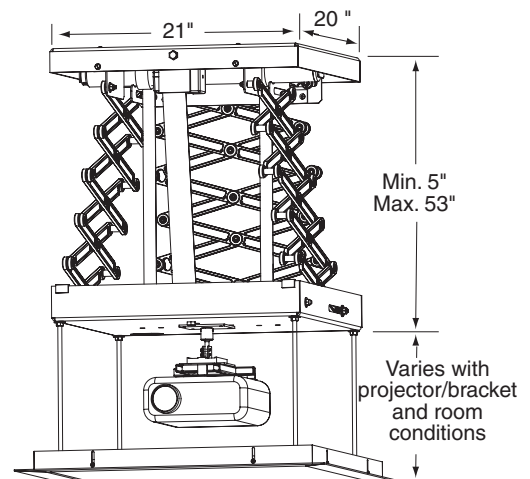

If you encounter any difficulties installing or servicing your Micro Projector Lift, call your dealer or Draper, Inc. in Spiceland, Indiana, 765-987-7999, or fax 765-987-7142.

Installing Optional Environmental Air Space Housing

The Environmental Air Space Housing is shipped pre-assembled in its shortest position. The height of the Environmental Air Space Housing can be adjusted by moving the screws to different mounting holes in side panels. You can install the Environmental Air Space Housing in a pre-assembled state or as separate components, which will require that the Environmental Air Space Housing be completely disassembled prior to installation.

Please note that if the Environmental Air Space Housing is to be installed in a space where there is no access from above the Environmental Air Space Housing, then it is recommended that the Micro projector Lift be installed to the upper section prior to installing the Environmental Air Space Housing. Please refer to drawing below for these instructions.

- ① Install top section of Environmental Air Space Housing using outer four holes located on top of upper section.
- ② Attach Micro Projector Lift to upper section of Environmental Air Space Housing through the inner four holes in the upper section with the $\frac{5}{16}$ " -18 x $\frac{7}{8}$ " hex head screws, $\frac{5}{16}$ " flat washers, and lock washers provided with Environmental Air Space housing. The lock washers should be used *above* the Environmental Air Space Housing (one per screw); the flat washers should be used *between* the Environmental Air Space Housing and the MPL (three flat washers per screw).
- ③ Attach the two flat panels of the middle section across from each other with the clinch nuts to the outside of the housing.
- ④ Attach the two middle section panels with the formed ends across from one another.
- ⑤ Attach lower section of Environmental Air Space Housing.

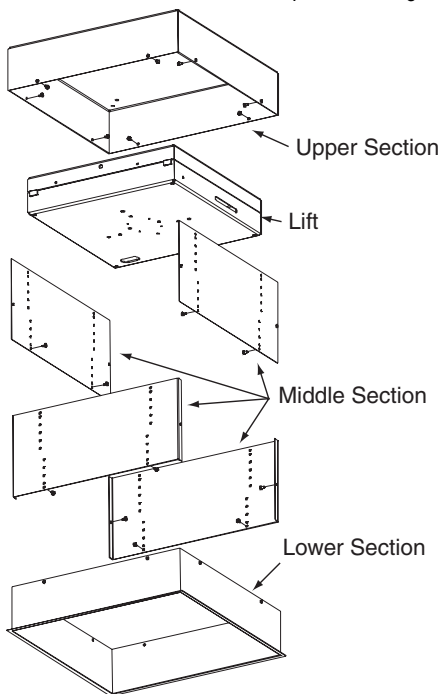

Environmental Air Space Housing, Lift and Closure

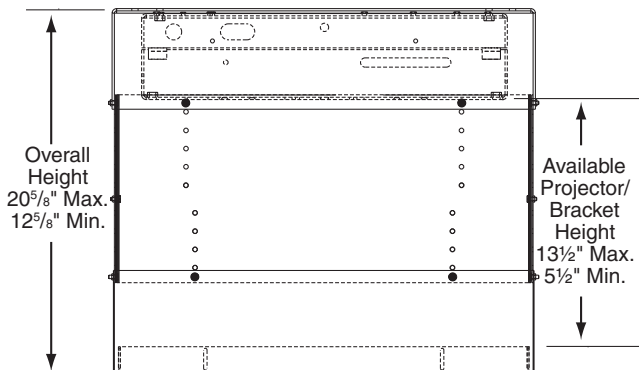

Installing Optional Ceiling Trim Kit

The Micro Projector Lift is available with a ceiling trim kit, which consists of the lower section of the Environmental Air Space Housing and the optional closure panel. Please refer to drawings below for these instructions.

- ① Install Micro Projector Lift as previously described in these instructions.
- ② Install bottom section of Environmental Air Space housing in opening. This can be accomplished by suspending with wire, or by mounting directly to the ceiling joists (if space permits).
- ③ Install projector and attach optional ceiling closure to Micro Projector Lift (see instructions on page 3).

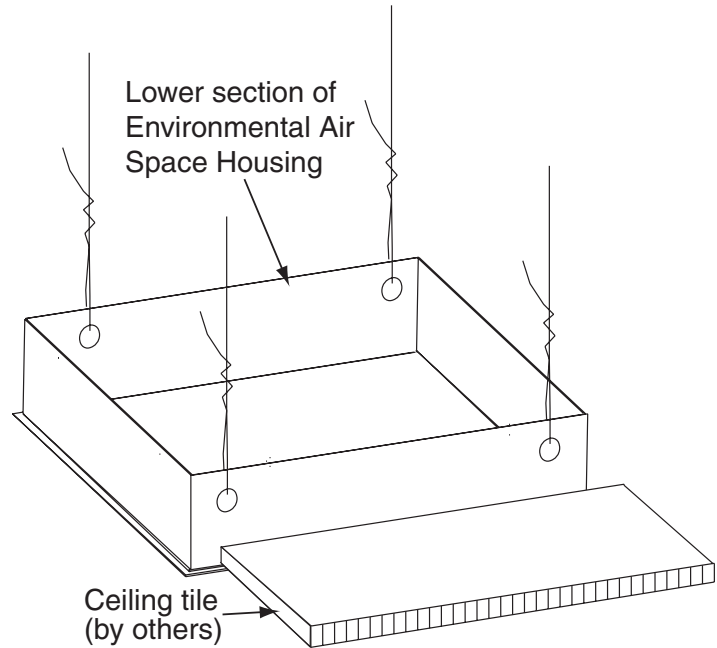

Mounting Hole Spacing

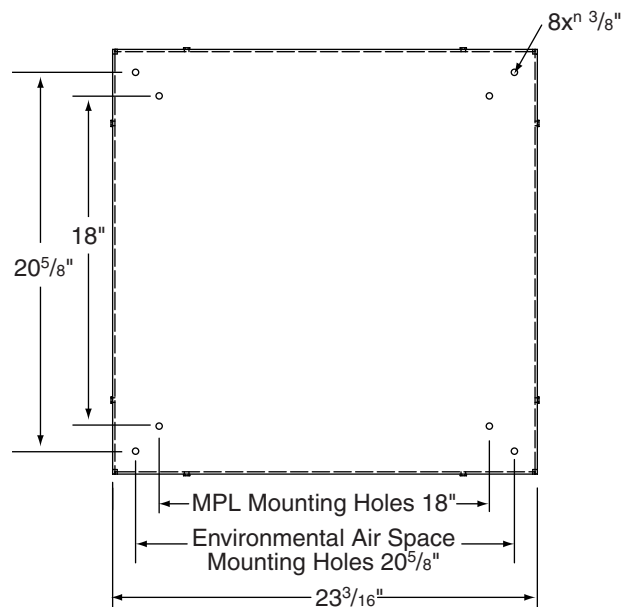

(Top view of Environmental Air Space Housing shown)

Installing Projector

Generally, the video projector should be suspended from the bottom pan according to projector manufacturer's instructions or using optional Low Profile Lift Bracket. If the Low Profile Lift Bracket is used, holes are pre-drilled for attachment.

If for any reason the hole placement must be changed, completely lower Micro Projector Lift before attempting to drill new holes.

The Micro Projector Lift has a grounded 110-120V AC, 60Hz power cord for projector power supply. The power cord is laced down the back scissor and is "hot" at all times. Control cables (maximum of four) should be laced through our Cable Management System (back scissor only—see method used for power cord). This will ensure that cords do not become tangled and damaged during Micro Projector Lift operation.

Unit and projection system should be operated, checked and adjusted as necessary at this time (see below for limit adjustment procedures).

⚠ Warning: Keep fingers & other objects away from ceiling closure & scissor mechanisms when unit is operating. Serious injury or damage can result.

Adjustments

⚠ CAUTION: Be sure all switches are in "off" position before adjusting limit switches. Always be prepared to shut lift off manually when new adjustment is being tested. Please refer to diagram at right for these instructions.

Limit switches for the Micro Projector Lift are preset at the factory. The "Up" (closed) limit switch is set for fully closed. The "down" (show) limit switch is set for 24". Once unit is in place, the "down" limit switch may need to be changed to stop the Micro Projector Lift closer to the ceiling (raise the "down" position) or further from the ceiling (lower the "down" position). Limit switches are located on the left end of roller (as seen from the front, or non-scissored end, of the unit) and are accessible to a screwdriver/Allen wrench (4mm or 5/32").

⚠ Caution: It is not uncommon to overheat the motor during initial installation when setting limits. The motor is thermally protected and will stop working until it has cooled to a safe temperature before it will start operating again.

Adjusting "Down" (show) position — "Down" position may be adjusted by turning limit switch adjustment socket number 1. Turning the socket clockwise will stop the Micro Projector Lift closer to the ceiling. Turning it counterclockwise will cause the lift to stop at a lower point.

Adjusting "Up" (closed) position — Because the "up" ("closed") position is preset at the factory, Draper does not recommend changing this position using the limit switch. The "up" position of the closure may be changed by changing the length of threaded rod (see instructions for closure installation below). If necessary, however, "up" position may be adjusted by turning limit switch adjustment socket number 2. Turning the socket counterclockwise creates a higher, or more fully closed position. Turning it clockwise creates a lower "UP" (closed) position.

⚠ Caution: Do not set limit switch so that the MPL motor is still running after the lift is closed. This could result in damage to the motor.

Installing Ceiling Closure

If your Micro Projector Lift is equipped with a ceiling closure system, it can be used as is, or in conjunction with a square of existing ceiling tile.

Please refer to the diagram at right for these instructions.

- ① If installing with ceiling tile, you may need to cut tile so that its overall dimensions are the same as (or slightly less than) the closure panel. Place tile into trim frame. Lay closure panel on top (back side) of ceiling tile, and tighten screws to hold in place.
- ② Attach 5/16" threaded rods to pem nuts in lift pan.
- ③ Run unit "up" until bottom pan stops at highest position. Mark position on 5/16" rods even with ceiling level and cut rods to length (removing from pan if convenient).
- ④ Run unit "down" until bottom pan stops at "show" position.
- ⑤ Attach closure to lower end of 5/16" rods by slipping into four corner slots and secure with nuts above and below slots.
- ⑥ Run unit "up" again to highest position. Measure distance by which panel fails to reach required "closed" height for surrounding ceiling.
- ⑦ Run unit "down" then readjust mounting of 5/16" rods in traveling grid to raise panel required distance.
- ⑧ Test unit operation to confirm that panel will stop in closed position just before touching ceiling.

NOTE: Immediately upon completion of the surrounding ceiling, units should be operated to confirm that optional ceiling closure panel stops just short of touching ceiling in closed position.

Low Profile Mount with Universal Bracket

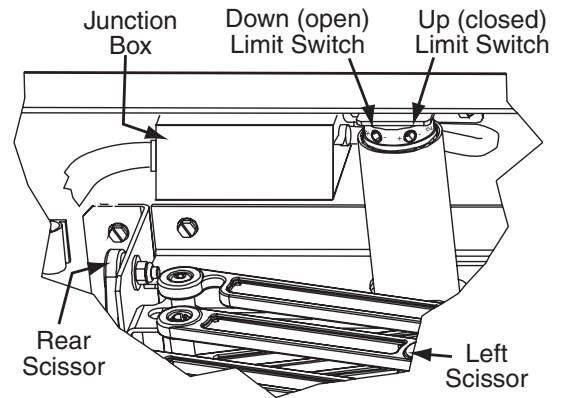
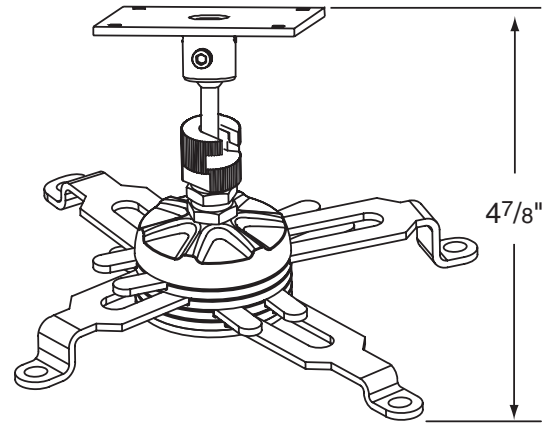

⚠ Caution: Beware of pinch points

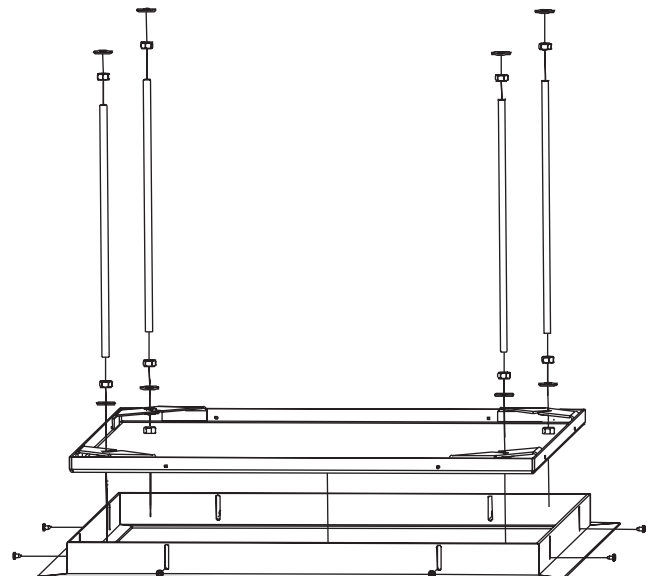
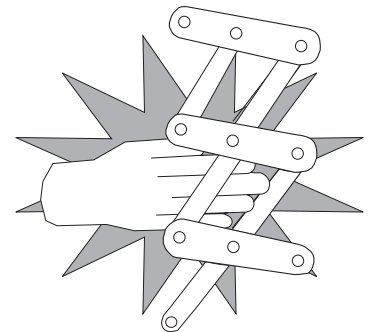

Wiring Diagrams

Single Station Control

Optional Multiple Station Control

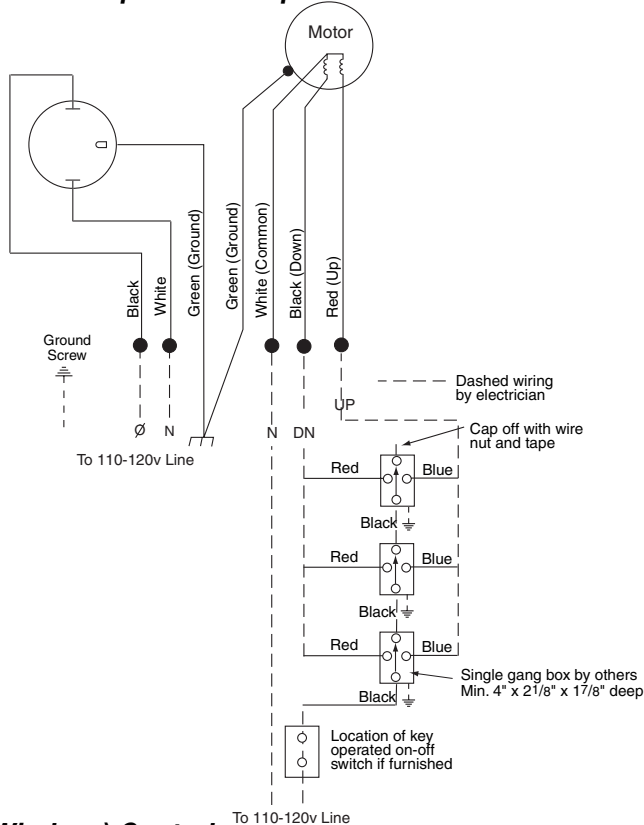
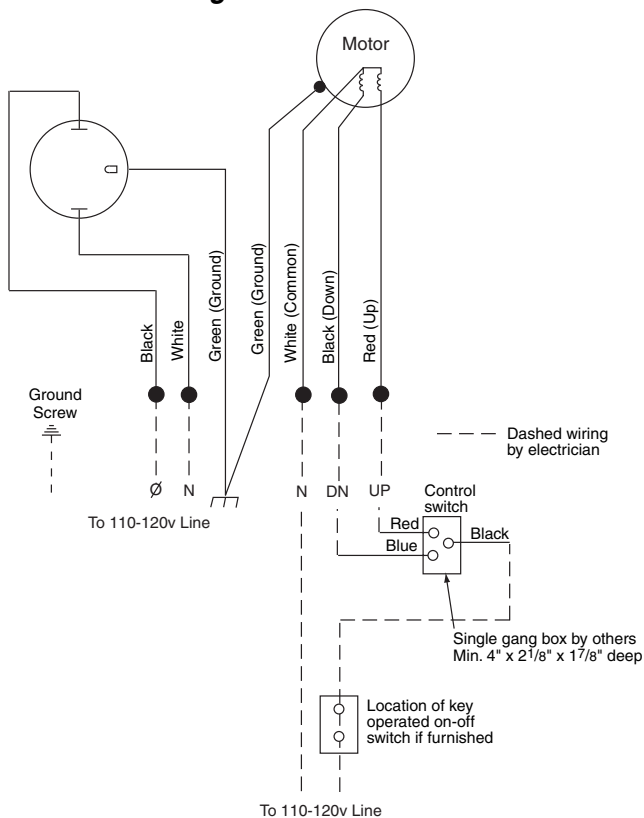

Optional Low Voltage (& Wireless) Control

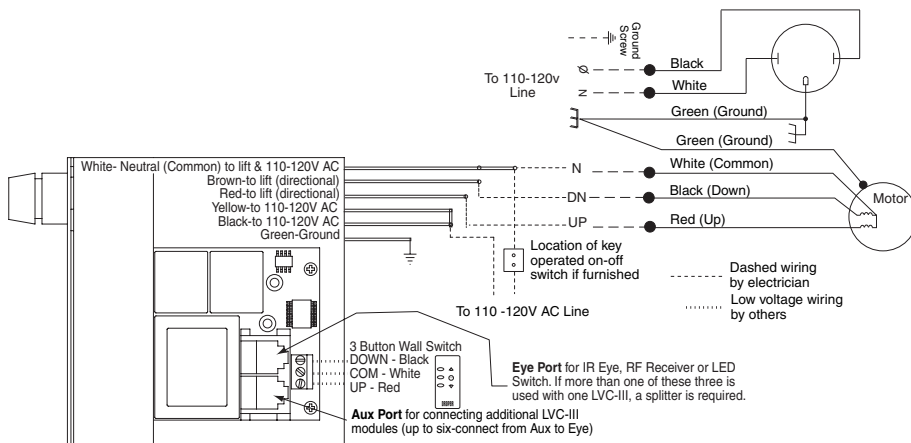

Optional MC1

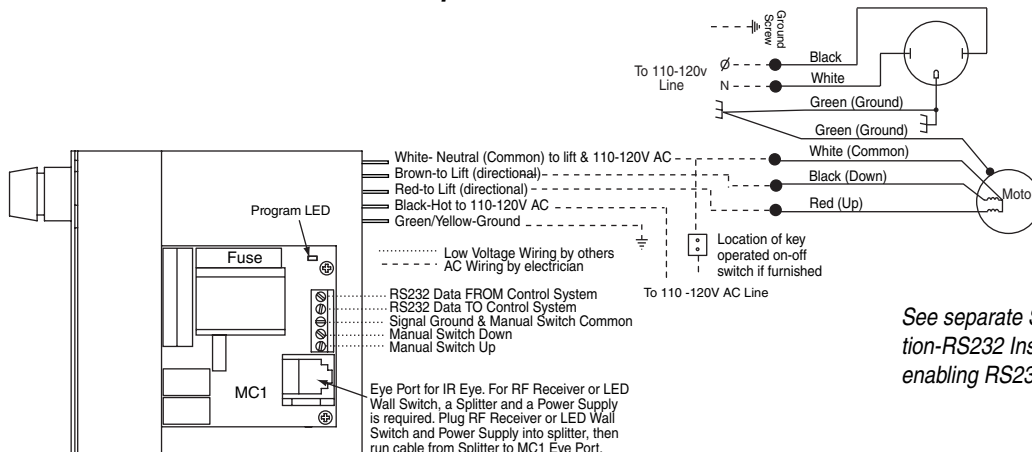

See separate Serial Communication-RS232 Instruction sheet for enabling RS232 with the MC1.