

## Installation Instructions

### Projector Mount Bracket

Model No. **ET-PKE300B**

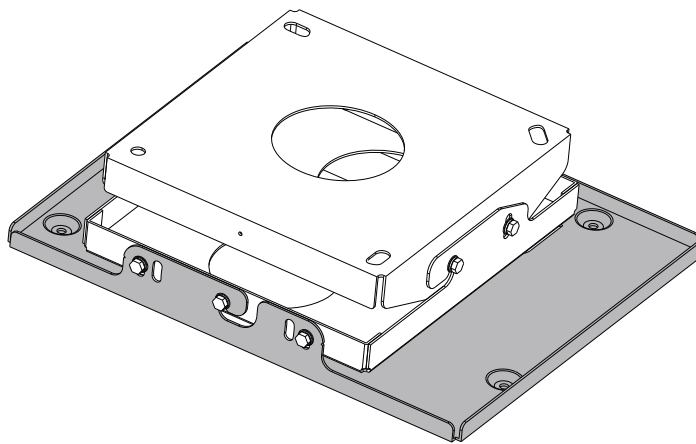

**ENGLISH**

\* The figure above shows a combination of this product and the separately sold ET-PKD120S ceiling mount bracket (for low ceilings).

Thank you for purchasing this Panasonic Product.

#### ■ To customers

The "Installation Instructions" is intended for use by installation personnel. Be sure to employ certified personnel to perform the installation. After installation, have the installation personnel return these "Installation Instructions" to you, and save it for future use. When moving or removing the projector, give this "Installation Instructions" to the installation personnel and have them perform the procedure.

#### ■ To installation personnel

Carefully read the "Installation Instructions" and install this product correctly and safely. Be sure to read through the section entitled "Read this first!" (page 3) before proceeding with the installation. After installation, return these "Installation Instructions" to the customer.



# Contents

<b>Read this first!</b> .....	<b>3</b>
<b>Product components</b> .....	<b>4</b>
<b>Standard installation dimensions</b> .....	<b>5</b>
<b>Installation</b> .....	<b>7</b>
Setting up the screen.....	7
Screws tightening torques .....	7
Installing the bracket to the projector.....	7
Attaching the projector drop-prevention kit.....	8
<b>Specifications</b> .....	<b>10</b>
<b>Dimensional relationship</b> .....	<b>Appendix</b>

## WARNING:

### **Installation work should only be carried out by the certified personnel.**

- If this product is not installed correctly, serious accidents may result.
- Follow the instructions specified in "Installation" of this manual, and perform secure installation.

### **Install the ceiling mount bracket in accordance with the structure and materials of the installation location.**

- If a mistake is made in the installation procedure, the ceiling mount bracket may fall down and an injury may result.

### **Mounting and installation must be carried out by two or more persons.**

- When installing the projector in an overhead location, for example, in a high ceiling, at least two persons will be required to handle the installation.

### **Make sure that your footing is safe and secure during installation.**

- If your footing is not secure, you may fall down or drop the unit, and an injury may result.

### **Do not loosen or remove the ceiling mount bracket screws and bolts unnecessarily.**

- The projector may fall down and an injury may result.

### **Do not install in a location that is not strong enough.**

- If the installation location is not strong enough, the unit may fall down and damage to the projector or an injury may result.

### **Do not install the ceiling mount bracket in humid or dusty locations or in locations where the ceiling mount bracket may come into contact with oily smoke or steam.**

- Using the projector under such conditions may result in fire or electric shock. Also, the oil will cause the plastic to deteriorate and the projector may fall down when installed on a ceiling.

### **Do not allow children to reach the supplied screws and metal fittings.**

- The supplied screws and metal fittings can cause personal injury if swallowed.
- If swallowed, seek medical advice immediately.

### **Do not disassemble or modify the ceiling mount bracket.**

- The projector may be damaged or fall, causing injury.

## CAUTION:

### **Only install a designated projector.**

### **Only install using a designated method.**

- The projector may fall down and be damaged, and an injury may result.

### **Do not install the unit in a location that may impede projector ventilation.**

- A fire may result.

### **Do not hang from or hang objects on the projector or ceiling mount bracket.**

- The projector may fall and cause injury.

### **Use only the specified ceiling mount bracket (for high ceilings or for low ceilings).**

- Failure to obey may result in dropping, damage to the projector, or injury.

### **When installing, always use the supplied components.**

- The unit may be damaged, or the projector may fall down and an injury may result.

### **Install the mounting screws and power cable in such a way that they will not make contact with metal objects inside the ceiling.**

- Electric shocks may result from contact with any metal objects inside the ceiling.

■ Panasonic takes no responsibility for any accident or damage caused by the installation of the ceiling mount bracket using methods that are not described or methods that do not use the parts specified in these Installation Instructions.

■ If products are no longer being used, they should be dismantled and removed by certified personnel as soon as possible.

# Product components

This is a ceiling mount bracket for installing projectors.

## ■ Applicable ceiling mount brackets and projectors

### ● Ceiling mount brackets

ET-PKD120H (for high ceilings) / ET-PKD120S (for low ceilings)



### ● Projectors

PT-EZ770 / PT-EZ590 / PT-EZ580 / PT-EZ57 / PT-EW730 / PT-EW650 / PT-EW640 / PT-EW550 / PT-EW540 / PT-EX800 / PT-EX620 / PT-EX610 / PT-EX520 / PT-EX510 / PT-FZ570 / PT-FW530 / PT-FX500

### Note

- In this document, the alphabet letters at the end of the projector part numbers are omitted.
- Models other than the above may also be supported. Refer to the operating instructions of the projector you are using.

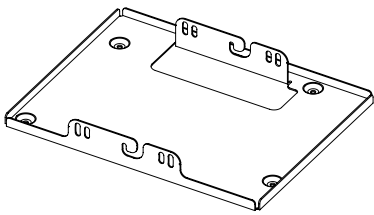
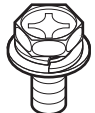
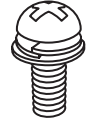
## ■ Structural components

Parts name	Form (number of parts)	Applications
Projector mount bracket	 × 1	This is used to install the projector itself. It has a function which allows adjustment of the left and right tilt.
Bolts	Captive washer hex head bolts (M6×16)  × 4	These are used to secure the brackets to the projector.
Projector drop-prevention kit	Captive washer Screw (M6×20)  × 1 Wire rope [2.0 mm (3/32") wire diameter, 800 mm (31-1/2")]  × 1 Flat washer (M8)  × 2	Prevents the projector from falling.

- Tightening torque for the screws are M6:  $4 \pm 0.5 \text{ N}\cdot\text{m}$ .
- When tightening up the screws, use a tool such as a torque screwdriver or torque wrench. Do not use electric screwdrivers or impact screwdrivers.

### Attention

- Dispose of the packaging materials properly after taking the product out of it.
- Store small parts in an appropriate manner, and keep them away from small children.

# Standard installation dimensions

The dimensional relationship between the screen and projector is shown below.

Establish the ceiling installation position after accessing the "Dimensional relationship diagram" (pages 5-6) and "Dimensional relationship" in the Appendix.

The projection distance can be adjusted using the zoom lens (except ET-ELW21). Check the projected image while making fine adjustments.

If the projector is equipped the lens shift function, the vertical position of the projected image can be adjusted. Then "H1/H2" will change according to lens shift amount.

## ■ Dimensional relationship diagram

(when using the ceiling mount bracket ET-PKD120S (for low ceilings))

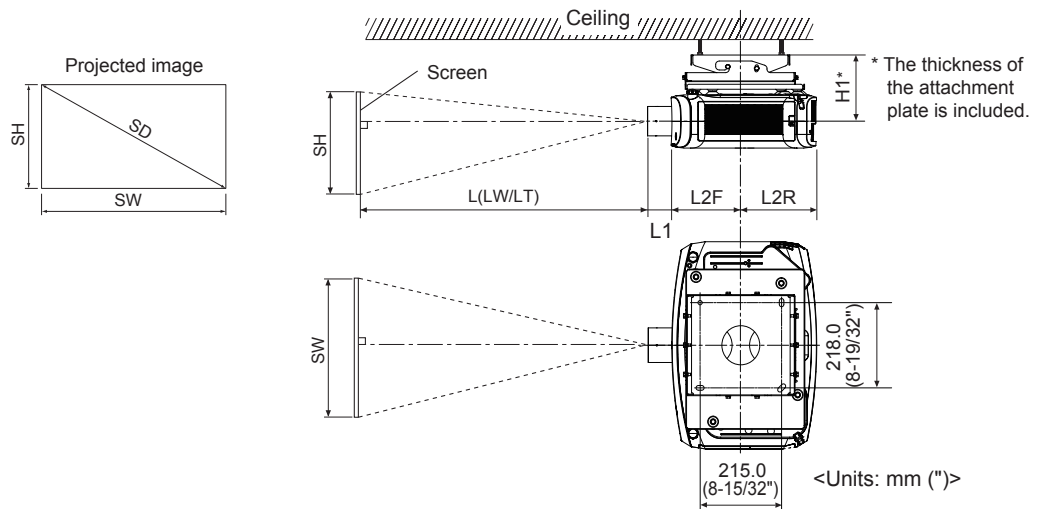

(when using the ceiling mount bracket ET-PKD120H (for high ceilings))

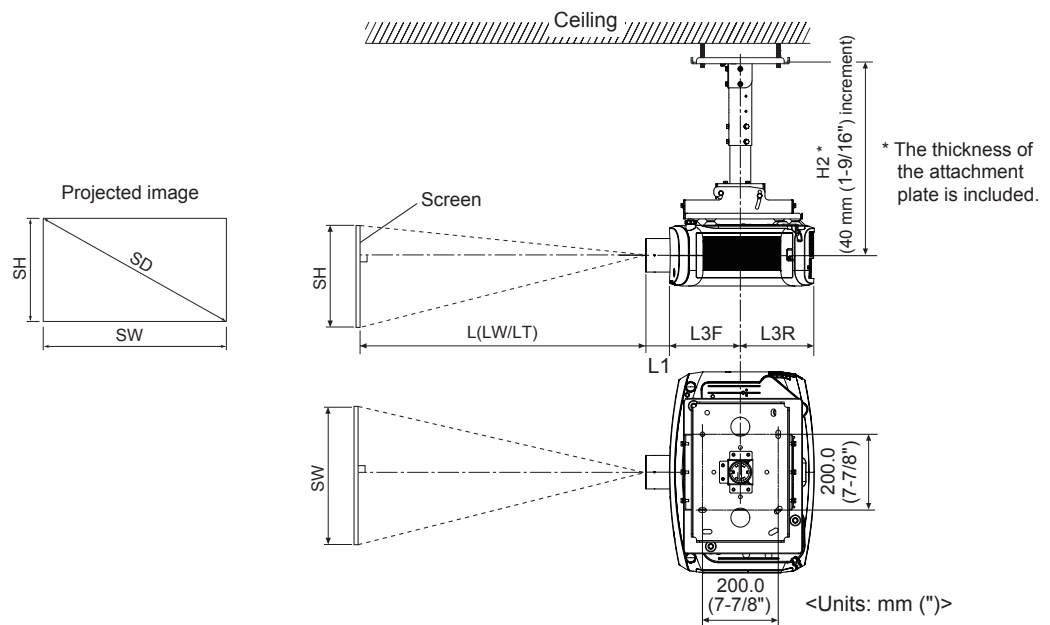

### Note

- This illustration assumes that the projector will be installed so that the projected image fills the screen and is properly aligned with it.
- This drawing is not in exact scale.

## Standard installation dimensions (continued)

SH	Projected image height	H1 / H2	Distance from the center of lens to the attachment plate (including plate thickness)
SW	Projected image width	L1	Lens protrusion dimension (from front of set to tip of lens)
SD	Projected image size	L2F / L3F	Distance from the center of attachment plate to the front end of lens
L(LW/LT)*1	Projection distance	L2R / L3R	Distance from the center of attachment plate to the rear end of projector

\*1 : LW : Minimum projection distance when the zoom lens is used

LT : Maximum projection distance when the zoom lens is used

### Note

- Depending on the product, the appearance may differ from the illustrations in these installation instructions.

### Attention

- Provide at 500 mm (19-11/16") of space on intake side of the projector and 1000 mm (39-11/16") of space on the exhaust side of the projector to ensure that the air intake and exhaust vents do not become blocked.
- Avoid setting up in places which are subject to sudden temperature changes, such as near an air conditioner or lighting equipment.

### ■ Dimensional relationship

For the formula of the projection distance (L) and the other specifications (H1 / H2, L1, L2F / L3F, L2R / L3R), refer to the appendix at the end of this instruction.

# Installation

After checking the height, width and structure of the installation location while referring to the “Dimensional relationship diagram” (pages 5-6) and “Dimensional relationship” in the Appendix, determine the appropriate positions for setting up the screen and installing the projector.

## Setting up the screen

Set up the screen according to the specified method in a position which takes into account the projection distance and angle and the type of screen being used.

## Screws tightening torques

M6.....4 ± 0.5 N•m

- Use a torque screwdriver or torque wrench to tighten screws and bolts to their specified tightening torques. Do not use electric screwdrivers or impact screwdrivers.

## Installing the bracket to the projector

Attach the projector mount bracket to the projector (sold separately).

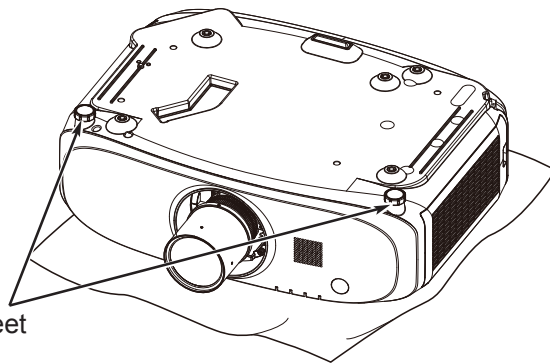

- 1 Place the projector upside down on top of a soft cloth.
- 2 Turn the adjustable feet (as shown on the left) clockwise to minimize the length of the feet.

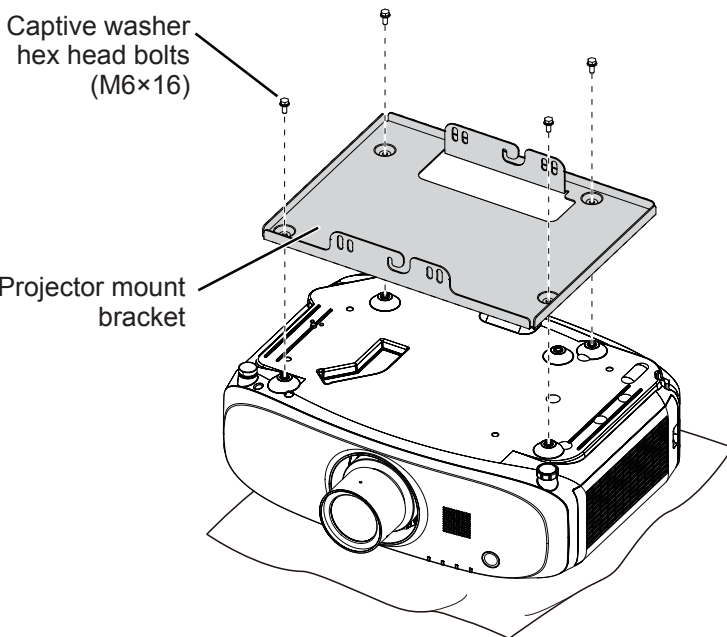

- 3 Secure the projector mount bracket to the bottom of the projector using the four supplied captive washer hex head bolts (M6x16) as illustrated on the left.

## Installation (continued)

### Attaching the projector drop-prevention kit

Secure the wire rope to the projector (sold separately).

#### Attention

- For the combination of the projector with the ceiling mount bracket (for low ceilings) ET-PKD120S (sold separately) and the ceiling mount bracket (for high ceilings) ET-PKD120H (sold separately), and the mounting of the wire rope to the ceiling, please refer to the installation instructions of the ceiling mount bracket ET-PKD120S (for low ceilings) and ET-PKD120H (for high ceilings).

(when using the ceiling mount bracket ET-PKD120S (for low ceilings))

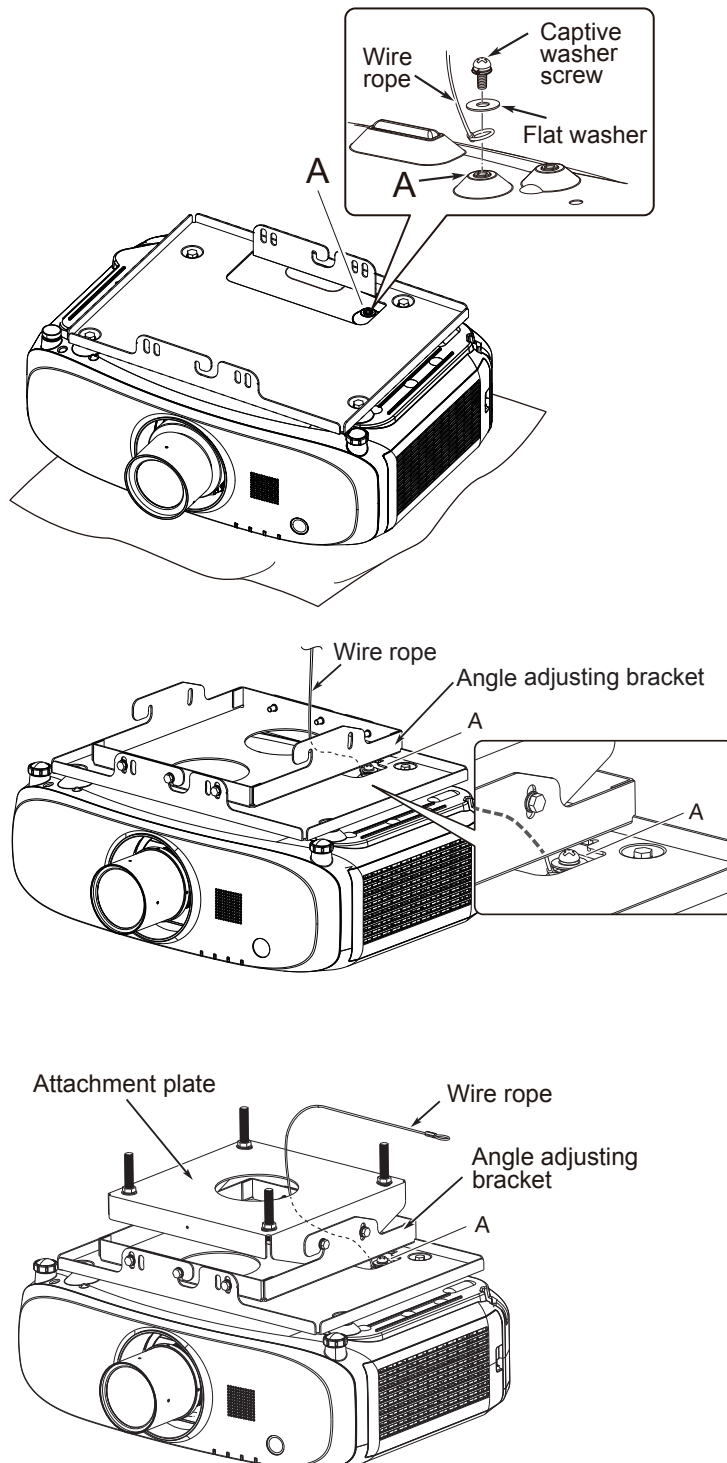

- 1 Secure one end of the wire rope with a captive washer screw (M6×20) to "A" on the projector as shown on the left.

#### Attention

- Be sure to use the supplied flat washers and wire rope.
- At this step, please keep the wire rope through the opening of the mounting bracket base.

#### Note

- One of the two supplied washers with this product is for the fixing of the wire rope to the projector and the other is for the fixing of the wire rope to the ceiling.

- 2 Mount the projector with the ceiling mount bracket ET-PKD120S (for low ceilings) to the angle adjusting bracket.

#### Attention

- At this step, please keep the wire rope through the opening of the angle adjusting bracket.

- 3 Mount the projector to the ceiling.

#### Attention

- For the combination of this projector and the ceiling mount bracket (sold separately), please refer to the installation instructions of the ceiling mount bracket ET-PKD120S (for low ceilings).
- 4 Pass the wire rope through the hole as shown in the figure on the left.



## Installation (continued)

(when using the ceiling mount bracket ET-PKD120H (for high ceilings))

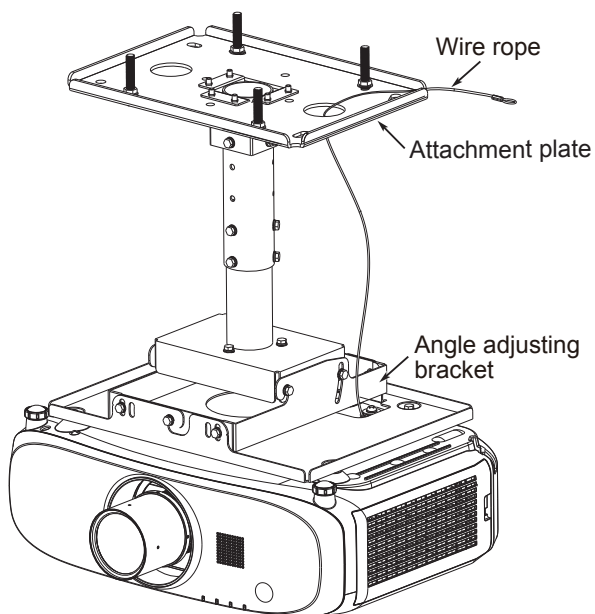
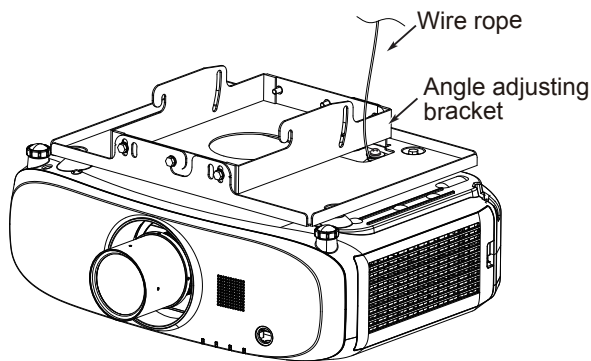
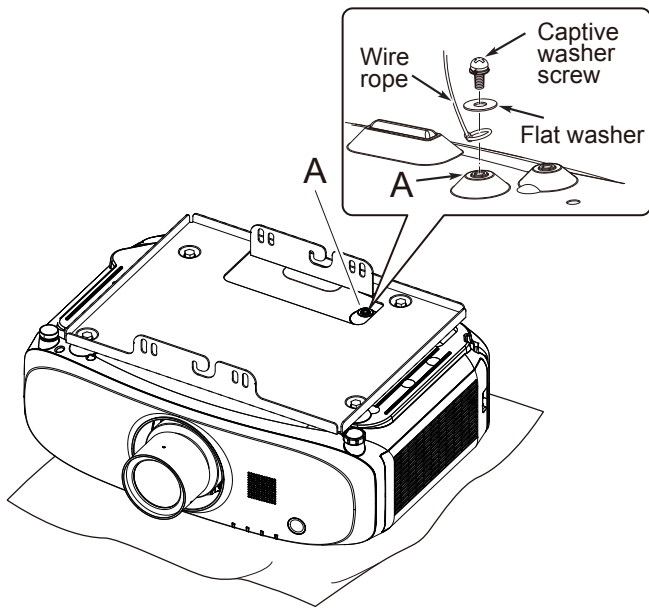

- 1 Secure one end of the wire rope with a captive washer screw (M6×20) to "A" on the projector as shown on the left.

### Attention

- Be sure to use the supplied flat washers and wire rope.
- At this step, please keep the wire rope through the opening of the mounting bracket base.

### Note

- One of the two supplied washers with this product is for the fixing of the wire rope to the projector and the other is for the fixing of the wire rope to the ceiling.

- 2 Mount the projector with the ceiling mount bracket ET-PKD120H (for high ceilings) to the angle adjusting bracket.

- 3 Mount the projector to the ceiling.

### Attention

- For the combination of this product and the ceiling mount bracket (sold separately), please refer to the installation instructions of the ceiling mount bracket ET-PKD120H (for high ceilings).
- 4 Pass the wire rope through the hole as shown in the figure on the left.

# Specifications

<b>External dimensions</b>	Width: 410 mm (16-5/32") Height: 56 mm (2-7/32") Length: 314 mm (12-3/8")
<b>Weight</b>	Approx. 2.2 kg (4.85 lbs)

# MEMO

---

# Panasonic Corporation

Web Site : <http://panasonic.net/avc/projector/>  
© Panasonic Corporation 2014

W0314GC1026 -ST