

Specifications

Main unit

Power supply		AC 100V-240V, 50Hz/60Hz	
Power consumption ¹	Maximum power consumption		840 W (8.8A-3.7A) (850VA) (The power consumption is 810W at 200-240V)
	On-mode power consumption (Operating mode)	[Normal]	700 W (100-120V) 675 W (200-240V)
		[Eco]	540 W (100-120V) 525 W (200-240V)
		[QUIET]	530 W (100-120V) 515 W (200-240V)
Standby mode power consumption	[Normal]	12 W	
	[Eco]	0.5 W	
BTU value		Max 2,866 BTU	
DLP™ chip	Size		[0.8 in] diagonal (16:10 aspect ratio)
	Display system		DLP™ chip x 1
	Number of pixels		2,304,000 pixels (1920 x 1200 dots)
Refresh rate		120 Hz Refresh rate varies depending on scanning frequency.	
Light source		Laser diode	
Light output ¹	Operation mode	[Normal]	10,000 lm/10,300 lm (Center)* ²
		[Eco]	8,000 lm
		[QUIET]	8,000 lm
Time until light output declines to 50% ²	Operation mode	[Normal]	20,000 hours
		[Eco]	24,000 hours
		[QUIET]	20,000 hours
Resolution		WUXGA (1920 x 1200 dots)	
Contrast ratio ¹		25,000:1 (All White/All Black, Dynamic Contrast [3])	
Screen size (diagonal)		[70-700 in] with standard lens (C1S600)	
Center to corner zone ratio ¹		90%	
Lens	PT-REZ10B/REZ10W		Powered zoom/focus lenses (TR:1.36-2.10:1), F-number (1.84-2.31)
	PT-REZ10LB/REZ10LW		Optional powered zoom/focus lenses
Lens shift (From the origin point of the lens mounter)		Vertical	(Max) ±60% (with ET-C1W400, ET-C1W500, ET-C1S600, ET-C1T700) (powered) (Max) ±50% (with ET-C1U100, ET-C1W300) (powered)
		Horizontal	(Max) ±29% (with ET-C1W400, ET-C1W500, ET-C1S600, ET-C1T700) (powered) (Max) ±23% (with ET-C1U100, ET-C1W300) (powered)
Installation		Ceiling/floor, front/rear, free 360-degree installation	
Compatible Signal	HDMI signal input		Moving image signal resolution: 480/60p, 576/50p to 4096 x 2160/60p Still image signal resolution: 640 x 480 to 3840 x 2400 (non-interlace) Dot clock frequency: 25 MHz to 594 MHz
	DisplayPort signal input		Moving image signal resolution: 720/60p to 4096 x 2160/60p Still image signal resolution: 640 x 480 to 3840 x 2400 (non-interlace) Dot clock frequency: 25 MHz to 594 MHz
	DIGITAL LINK ⁴ signal input		Moving image signal resolution: 480/60p, 576/50p to 4096 x 2160/60p Still image signal resolution: 640 x 480 to 3840 x 2400 (non-interlace) Dot clock frequency: 25 MHz to 297 MHz
	SDI ⁵ signal input		HD-SDI signal 3G-SDI signal 12G-SDI signal
Terminals	<HDMI 1 IN> <HDMI 2 IN>		HDMI x 2 Deep Color, compatible with HDCP2.3, 4K/60p signal ⁶
	<DisplayPort IN>		DisplayPort x 1 Deep Color, compatible with HDCP 2.3, 4K/60p signal ⁶
	<MULTI SYNC IN>		BNC x 1 TTL high impedance
	<MULTI SYNC OUT>		BNC x 1 TTL output: Maximum 10 mA
	<SERIAL IN>		D-sub 9-pin (female) x 1 for external control (RS-232C compliant)
	<SERIAL OUT>		D-sub 9-pin (male) x 1 for link control (RS-232C compliant)
	<REMOTE 1 IN>		M3 stereo mini-jack x 1 for wired remote control
	<REMOTE 1 OUT>		M3 stereo mini-jack x 1 for link control (for wired remote control)

Terminals	<REMOTE 2 IN>	D-sub 9-pin (female) x 1 for external control (parallel)
	<LAN>	RJ-45 x 1 for network connection, PJLink™ (class 2) compatible, 10Base-T/100Base-TX, Art-Net compatible
	<USB>	USB connector (Type A) x 1 for optional AJ-WM50 Series Wireless Module/USB memory stick
	<DC OUT>	USB connector (Type A) x 1 for power supply, DC 5 V, total of 2 A
	<SLOT>	SLOT x 1 Open slot, for function boards, Intel® SDM compatible
Supported Internet Protocol version		IPv4, IPv6 ⁷
Power cord length		3.0 m [118 1/8 in]
Cabinet materials		Molded plastic
Dimension	Width	498 mm [19 5/8 in] (excluding protrusions)
	Height	212 mm [8 3/8 in] (with the feet at shortest position)
		196 mm [7 11/16 in] (excluding feet)
	Depth	PT-REZ10B/REZ10W
PT-REZ10LB/REZ10LW		538 mm [21-3/16 in] (excluding protrusions)
Weight ⁸	PT-REZ10B/REZ10W	Approx. 28.7 kg (63.3 lbs.) (including standard zoom lens)
	PT-REZ10LB/REZ10LW	Approx. 27.0 kg (59.5 lbs.) (excluding the optional lens)
Operating noise ¹	[Normal]	36 dB
	[Eco]	36 dB
	[Quiet]	33 dB
Laser Classification	Laser Class	Class 1 (IEC/EN 60825-1:2014) China: Class 3R (IEC60825-1:2007)
	Risk Group	Risk Group 2 (IEC 62471-5:2015): ET-C1U100, ET-C1W300, ET-C1W400, ET-C1W500, ET-C1S600
		Risk Group 3 (IEC 62471-5:2015): ET-C1T700
Operating environment	Operating temperature	0-45 °C (32-113 °F) ⁹
	Operating humidity	10-80% (no condensation)
IP rating (dust protection) ¹⁰		IP5X (only the optical engine and light source module)

Remote control unit

Power supply	3V DC (AAA/R03/LR03 battery x 2)	
Operation range	Approx. 30 m [98 ft 5 in] (when operated directly in front of signal receiver)	
Dimensions	Width	48 mm [1 7/8 in]
	Height	145 mm [5 23/32 in]
	Depth	27 mm [1 1/16 in]
Weight	Approx. 102 g (3.60 ozs.) including batteries	

Supplied accessories

Power cord (x 1) (x 2 for Europe / ASIA models)
 Wireless/wired remote control unit (x 1)
 Batteries for remote control (AAA/R03 or AAA/LR03 battery x 2)
 SLOT adapter (x 1)

Other Applications

Multi Monitoring Control Software (for Windows)
 Logo Transfer Software (for Windows)
 Geometry Manager Pro (for Windows)
 Smart Projector Control (for iOS/Android™)
 Projector Network Setup Software (for Windows)

Supported services of Control via LAN

Art-net
 PJLink™ (class 2)
 Crestron Connected™ V2
 Crestron XiO Cloud™
 AMX Device Discovery

Optional accessories

Lens	Zoom lens	ET-C1U100 (0.308-0.330:1)
		ET-C1W300 (0.550-0.690:1)
		ET-C1W400 (0.680-0.950:1)
		ET-C1W500 (0.940-1.39:1)
		ET-C1S600 (1.36-2.10:1) Note: This product is equivalent to the lens attached to the projector model with standard zoom lens.
		ET-C1T700 (2.07-3.38:1)
Ceiling Mount Bracket	with 6-axis adjustment for high ceilings	ET-PKD130H
	for high ceilings	ET-PKD120H
	for low ceilings	ET-PKD120S
Attachment for Ceiling Mount Bracket		ET-PKD130B
Function Board	12G-SDI Terminal Board	TY-SB01QS
	DIGITAL LINK Terminal Board	TY-SB01DL
	Wireless Presentation System Receiver Board	TY-SB01WP
12G-SDI Terminal Board		TY-SB01FB
DIGITAL LINK Switcher		ET-YFB200G
Digital Interface Box		ET-YFB100G
Wireless module		AJ-WM50 Series Note: Product availability may vary by country or region. The suffix at the end of the model number is omitted. Operating Temperature: 0–40 °C (32–104 °F).
Early Warning Software		ET-SWA100 Series Note: Part number suffix may differ depending on the license type.
NFC Upgrade Kit		ET-NUK10 Note: Product availability may vary by country or region.
Geometry Manager Pro Upgrade kit (preactivated)		ET-UK20
Auto Screen Adjustment Upgrade kit (preactivated)		ET-CUK10/CUK10P
Wireless Presentation System PressIT		TY-WPS1 (basic set)

Weights and dimensions shown are approximate. Specifications subject to change without notice.

1 Measurement, measuring conditions, and method of notation all comply with ISO/IEC 21118:2020 international standards.

2 Average light output value of all shipped products measured at center of screen in [NORMAL] Mode.

3 Around this time, light output will have decreased by approximately 50%. IEC62087: 2008 Broadcast contents, Dynamic Contrast [3], under conditions with 35°C (95°F), 700m (2297ft) above sea level, and 0.15 mg/m³ of particulate matter. Estimated time until light output declines to 50% varies depending on environment.

4 Requires TY-SB01DL Interface Board for DIGITAL LINK.

5 Requires TY-SB01QS Interface Board for 12G-SDI Input.

6 4K/60p signals are converted to the projector's resolution upon projection.

7 Optional wireless module AJ-WM50 only supports IPv4.

8 Average value. May differ depending on the actual unit.

9 When using the projector at an altitude lower than 2700m (8858ft) above sea level, and the operating environment temperature becomes 30°C (86°F) or higher, the light output may be reduced to protect the projector.

When using the projector at an altitude between 2700m (8858ft) and 4200m (13780ft), and the operating environment temperature becomes 25°C (77°F) or higher, the light output may be reduced to protect the projector.

10 The measurement method and measurement conditions are based on IEC standard 60529 IP5X (dustproof type). The dustproof performance of this unit is not guaranteed to be free from damage or failure under all conditions (environment with conductive dust, etc.).

Terminals

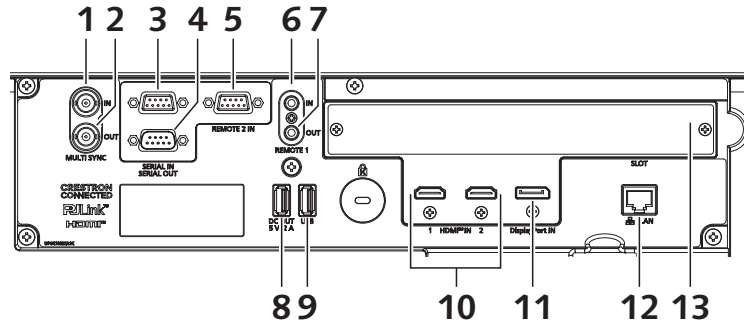

1	MULTI SYNC IN	8	DC OUT
2	MULTI SYNC OUT	9	USB
3	SERIAL IN	10	HDMI 1 IN / HDMI 2 IN
4	SERIAL OUT	11	DisplayPort IN
5	REMOTE 2 IN	12	LAN
6	REMOTE 1 IN	13	SLOT
7	REMOTE 1 OUT		

Dimensions

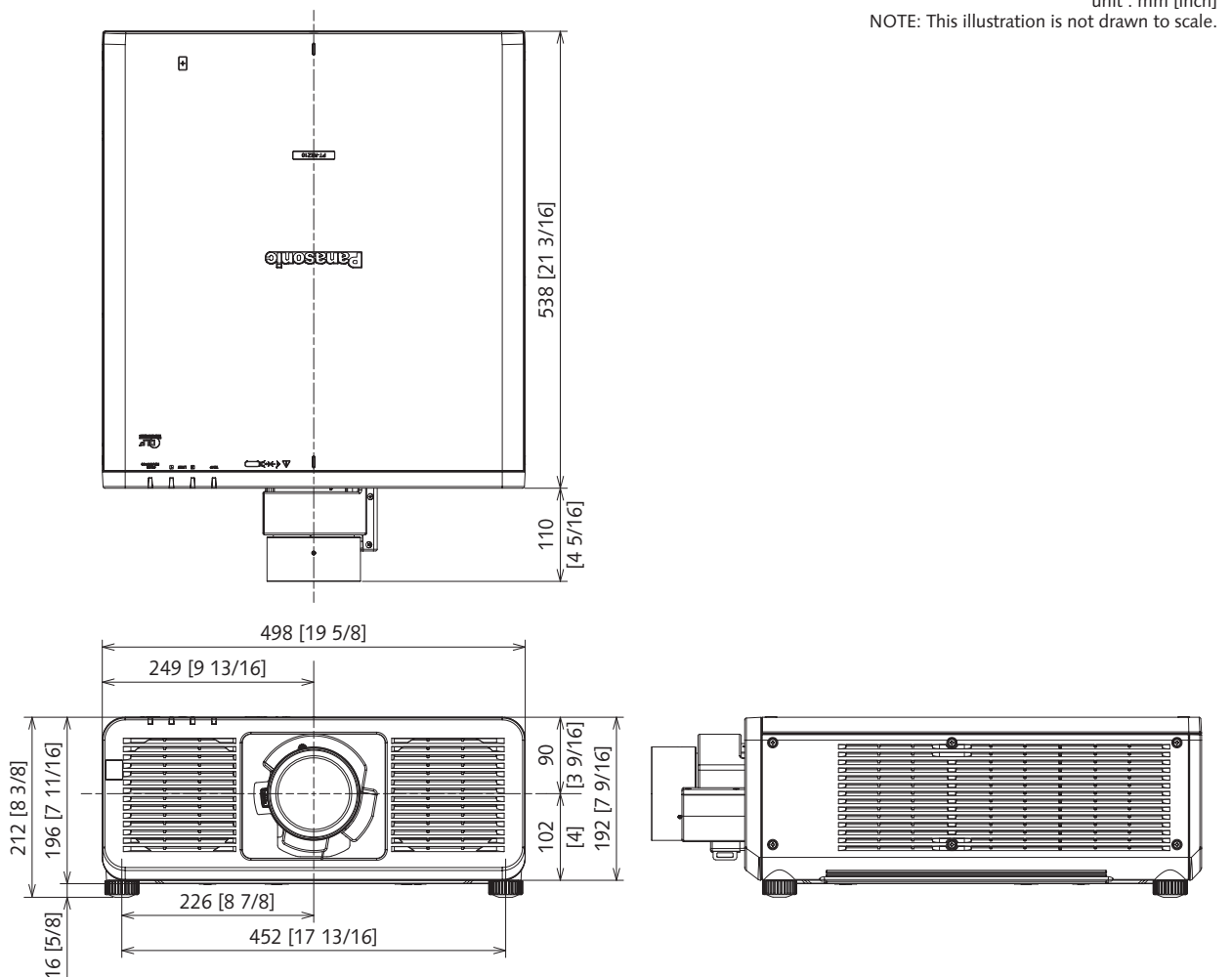

Projected image and throw distance

Install the projector referring to the projected image size and projection distance. Image size and image position can be adjusted in accordance with the screen size and screen position.

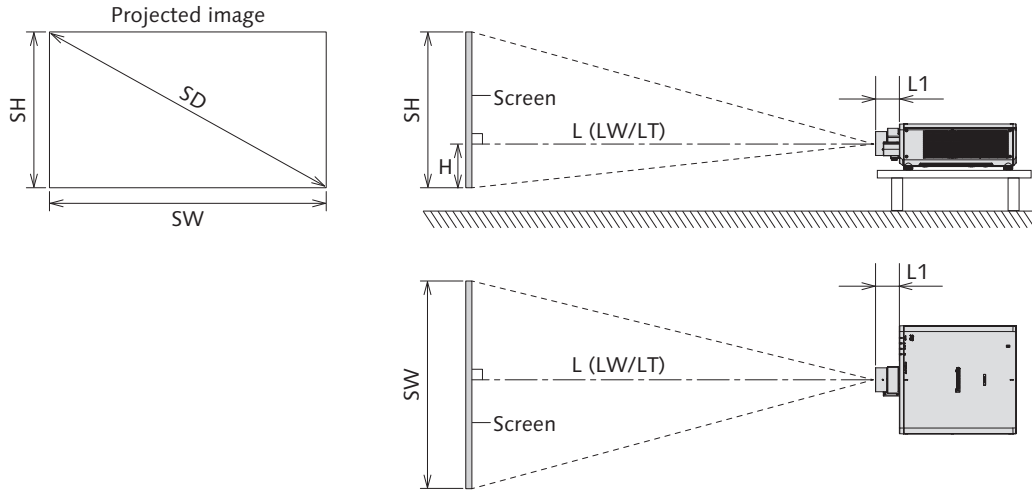

Note

- This illustration is prepared on the assumption that the projected image size and position have been aligned to fit full in the screen.
- This illustration is not drawn to scale.
- The values are approximate.

SH	Projected image height
SW	Projected image width
SD	Projected image size
H	Distance from the lens center to the bottom edge of the projected image
L	Projection distance (distance from the front end of the projection lens to the screen)
	LW Minimum projection distance when the Zoom Lens is used
	LT Maximum projection distance when the Zoom Lens is used
L1	Lens protrusion dimension (distance from the front surface of the projector to the front end of the projection lens)

unit : m

Projection lens Model No.	Lens protrusion dimension (L1) (approximate value)
ET-C1U100	0.384
ET-C1W300	0.155
ET-C1W400	0.149
ET-C1W500	0.144
ET-C1S600	0.110
ET-C1T700	0.160

Standard setting position

Illustrations show the projector installed using optional ceiling mountbracket ET-PKD130H, optional bracket assembly ET-PKD130B.

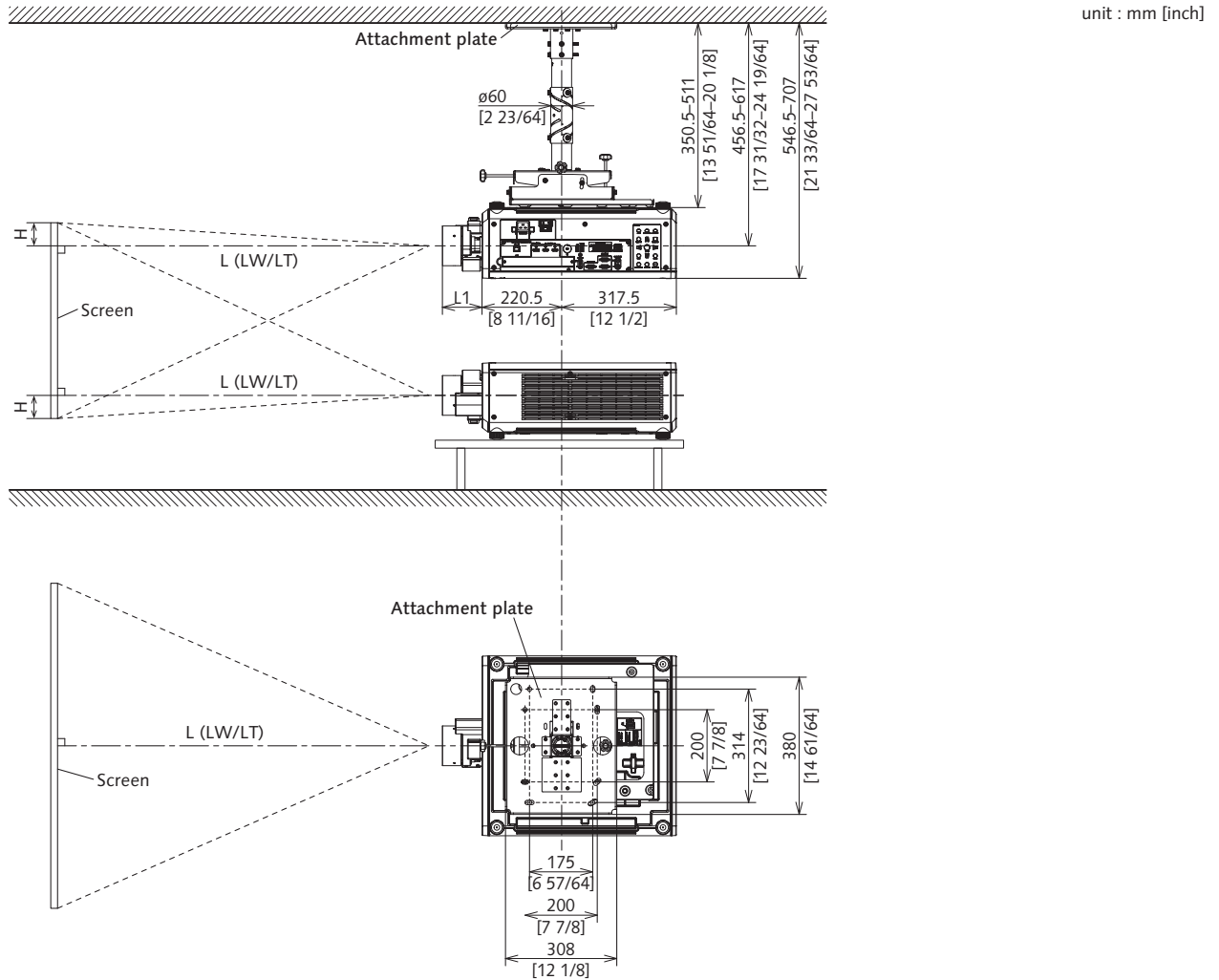

Caution

- All construction work should be done by a qualified technician.
- When mounting to the ceiling, use the special mounting bracket.
Furthermore, in order to prevent it from falling down from the ceiling, use the supplied wire on the mounting bracket.

Note

- This illustration is prepared on the assumption that the projected image size and position have been aligned to fit full in the screen.
- This illustration is not drawn to scale.
- The values are approximate.

Illustrations show the projector installed using optional ceiling mountbracket ET-PKD120H, optional bracket assembly ET-PKD130B.

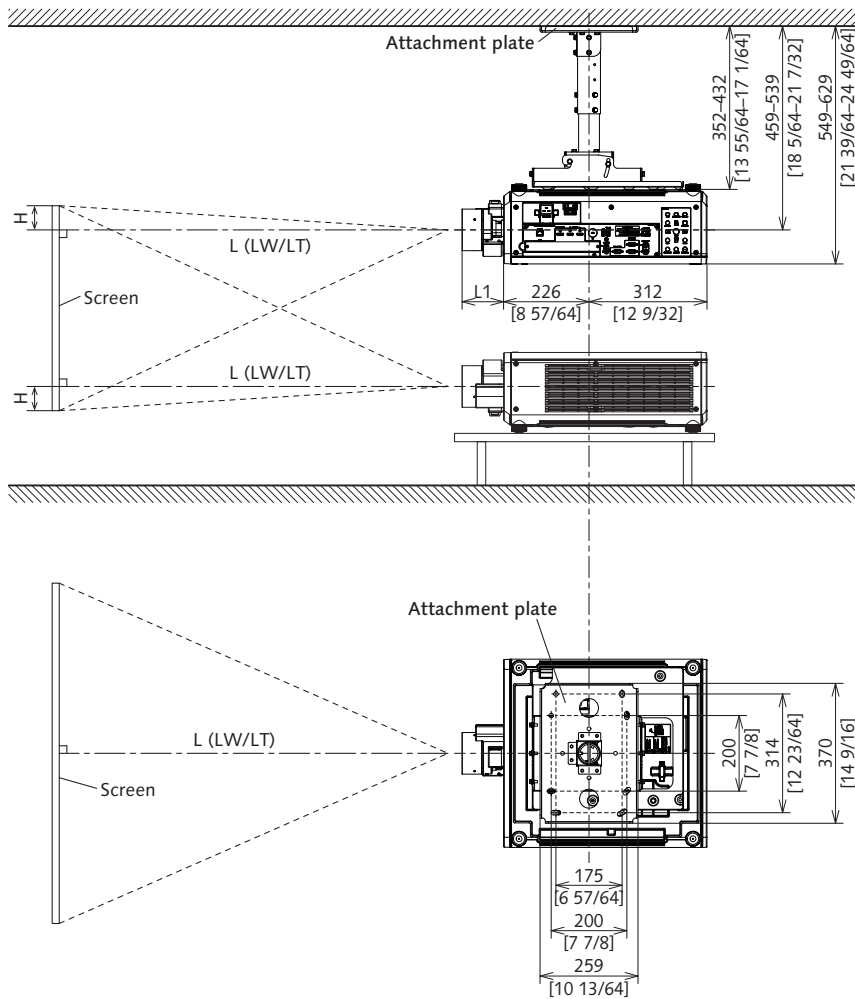

Caution

- All construction work should be done by a qualified technician.
- When mounting to the ceiling, use the special mounting bracket. Furthermore, in order to prevent it from falling down from the ceiling, use the supplied wire on the mounting bracket.

Note

- This illustration is prepared on the assumption that the projected image size and position have been aligned to fit full in the screen.
- This illustration is not drawn to scale.
- The values are approximate.

Illustrations show the projector installed using optional ceiling mountbracket ET-PKD120S, optional bracket assembly ET-PKD130B.

unit : mm [inch]

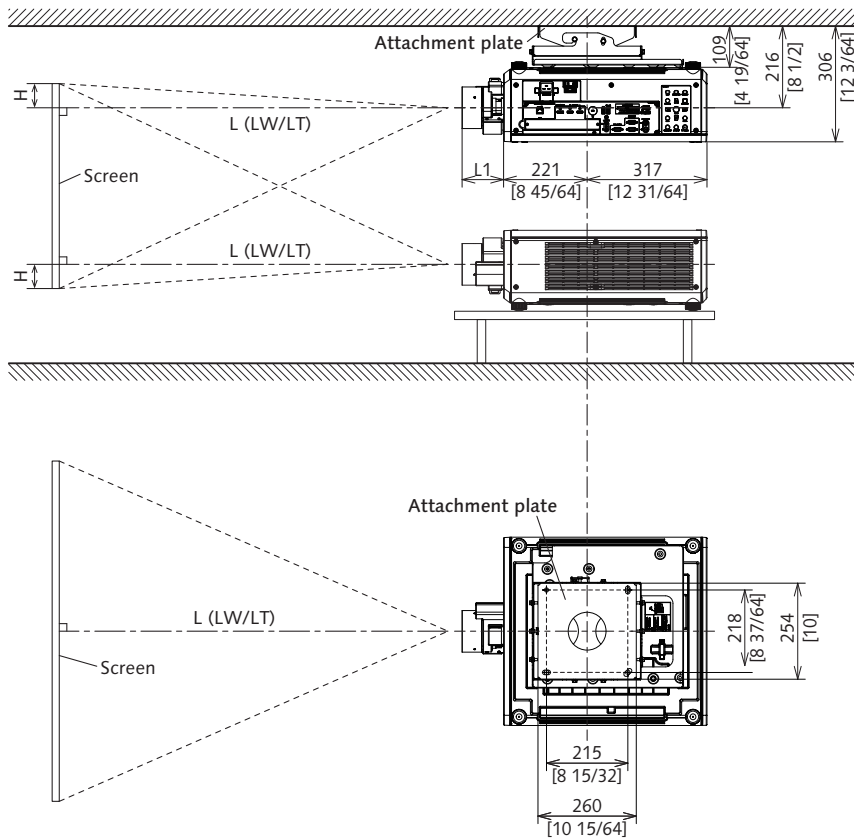

Caution

- All construction work should be done by a qualified technician.
- When mounting to the ceiling, use the special mounting bracket. Furthermore, in order to prevent it from falling down from the ceiling, use the supplied wire on the mounting bracket.

Note

- This illustration is prepared on the assumption that the projected image size and position have been aligned to fit full in the screen.
- This illustration is not drawn to scale.
- The values are approximate.

Projection distance

A ±5% error in listed projection distances may occur.

When [SCREEN ADJUSTMENT] is used, distance is corrected to become smaller than the specified image size.

Screen aspect ratio 16:10

Unit: meters

Projection lens Model No.		ET-C1U100 ²		ET-C1W300		ET-C1W400		ET-C1W500		ET-C1S600		ET-C1T700			
Throw ratio ¹		0.308 - 0.330:1		0.550 - 0.690:1		0.680 - 0.950:1		0.940 - 1.39:1		1.36 - 2.10:1		2.07 - 3.38:1			
Projected image size		Projection distance (L)													
Diagonal (SD)		Min. (LW)	Max. (LT)	Min. (LW)	Max. (LT)	Min. (LW)	Max. (LT)	Min. (LW)	Max. (LT)	Min. (LW)	Max. (LT)	Min. (LW)	Max. (LT)	Min. (LW)	Max. (LT)
m	inches														
1.78	70	0.942	1.508	0.45	0.48	0.82	1.03	1.01	1.42	1.41	2.08	2.03	3.15	3.09	5.07
2.03	80	1.077	1.723	0.51	0.55	0.94	1.18	1.16	1.63	1.61	2.39	2.33	3.61	3.55	5.81
2.29	90	1.212	1.939	0.58	0.63	1.06	1.33	1.31	1.84	1.82	2.69	2.63	4.06	4.00	6.54
2.54	100	1.346	2.154	0.65	0.70	1.18	1.49	1.46	2.05	2.03	2.99	2.93	4.52	4.46	7.28
3.05	120	1.615	2.585	0.79	0.85	1.43	1.79	1.76	2.46	2.44	3.60	3.53	5.44	5.37	8.75
3.81	150	2.019	3.231	0.99	1.07	1.79	2.25	2.21	3.09	3.06	4.51	4.43	6.82	6.73	10.96
5.08	200	2.692	4.308	1.34	1.44	2.40	3.01	2.96	4.13	4.09	6.03	5.93	9.11	9.01	14.64
6.35	250	3.365	5.385	1.68	1.80	3.01	3.77	3.71	5.18	5.12	7.55	7.43	11.40	11.28	18.32
7.62	300	4.039	6.462	2.02	2.17	3.62	4.53	4.46	6.22	6.15	9.07	8.92	13.70	13.56	22.00
8.89	350	4.712	7.539	2.37	2.54	4.22	5.29	5.22	7.26	7.18	10.59	10.42	15.99	15.83	25.68
10.16	400	5.385	8.616	2.71	2.91	4.83	6.06	5.97	8.30	8.21	12.10	11.92	18.28	18.11	29.37
12.70	500	6.731	10.770	3.39	3.64	6.05	7.58	7.47	10.39	10.27	15.14	14.92	22.87	22.66	36.73
15.24	600	8.077	12.923	4.08	4.38	7.26	9.10	8.97	12.48	12.33	18.18	17.92	27.46	27.21	44.09
17.78	700	9.423	15.077	4.77	5.11	8.48	10.63	10.47	14.56	14.39	21.22	20.91	32.04	31.76	51.45
20.32	800	10.770	17.231	5.45	5.85	-	-	-	-	-	-	-	-	-	-
22.86	900	12.116	19.385	6.14	6.58	-	-	-	-	-	-	-	-	-	-
25.40	1000	13.462	21.539	6.82	7.32	-	-	-	-	-	-	-	-	-	-

Projection lens Model No.		ET-C1U100		ET-C1W300		ET-C1W400 ET-C1W500 ET-C1S600 ET-C1T700	
Throw ratio ¹							
Projected image size		Height position (H)					
Diagonal (SD)		Min. (LW)	Max. (LT)				
m	inches						
1.78	70	0.942	1.508	0.00 - 0.94	0.00 - 0.94	-0.09 - 1.04	
2.03	80	1.077	1.723	0.00 - 1.08	0.00 - 1.08	-0.11 - 1.19	
2.29	90	1.212	1.939	0.00 - 1.21	0.00 - 1.21	-0.12 - 1.33	
2.54	100	1.346	2.154	0.00 - 1.35	0.00 - 1.35	-0.14 - 1.48	
3.05	120	1.615	2.585	0.00 - 1.62	0.00 - 1.62	-0.16 - 1.78	
3.81	150	2.019	3.231	0.00 - 2.02	0.00 - 2.02	-0.20 - 2.22	
5.08	200	2.692	4.308	0.00 - 2.69	0.00 - 2.69	-0.27 - 2.96	
6.35	250	3.365	5.385	0.00 - 3.37	0.00 - 3.37	-0.34 - 3.70	
7.62	300	4.039	6.462	0.00 - 4.04	0.00 - 4.04	-0.40 - 4.44	
8.89	350	4.712	7.539	0.00 - 4.71	0.00 - 4.71	-0.47 - 5.18	
10.16	400	5.385	8.616	0.00 - 5.39	0.00 - 5.39	-0.54 - 5.92	
12.70	500	6.731	10.770	0.00 - 6.73	0.00 - 6.73	-0.67 - 7.40	
15.24	600	8.077	12.923	0.00 - 8.08	0.00 - 8.08	-0.81 - 8.89	
17.78	700	9.423	15.077	0.00 - 9.42	0.00 - 9.42	-0.94 - 10.37	
20.32	800	10.770	17.231	0.00 - 10.77	-	-	
22.86	900	12.116	19.385	0.00 - 12.12	-	-	
25.40	1000	13.462	21.539	0.00 - 13.46	-	-	

¹ The throw ratio is based on the value during projection with the projected image size of 2.54 m [100 in].

However, the throw ratio for ET-C1U100 is based on the value during projection with the projected image size of 3.81 m [150 in].

² For ET-C1U100, fine text and images may not be displayed clearly during projection with the projected image size over 15.24 m [600 in].

Screen aspect ratio 16:10

Unit: feet

Projection lens Model No.		ET-C1U100 ²		ET-C1W300		ET-C1W400		ET-C1W500		ET-C1S600		ET-C1T700			
Throw ratio ¹		0.308 - 0.330:1		0.550 - 0.690:1		0.680 - 0.950:1		0.940 - 1.39:1		1.36 - 2.10:1		2.07 - 3.38:1			
Projected image size		Projection distance (L)													
Diagonal (SD)		Min. (LW)	Max. (LT)	Min. (LW)	Max. (LT)	Min. (LW)	Max. (LT)	Min. (LW)	Max. (LT)	Min. (LW)	Max. (LT)	Min. (LW)	Max. (LT)		
m	inches														
1.78	70	3.09	4.95	1.48	1.58	2.69	3.38	3.31	4.66	4.63	6.82	6.66	10.34	10.14	16.63
2.03	80	3.53	5.65	1.67	1.80	3.08	3.87	3.81	5.35	5.28	7.84	7.64	11.84	11.65	19.06
2.29	90	3.98	6.36	1.90	2.07	3.48	4.36	4.30	6.04	5.97	8.83	8.63	13.32	13.12	21.46
2.54	100	4.42	7.07	2.13	2.30	3.87	4.89	4.79	6.73	6.66	9.81	9.61	14.83	14.63	23.89
3.05	120	5.30	8.48	2.59	2.79	4.69	5.87	5.77	8.07	8.01	11.81	11.58	17.85	17.62	28.71
3.81	150	6.62	10.60	3.25	3.51	5.87	7.38	7.25	10.14	10.04	14.80	14.53	22.38	22.08	35.96
5.08	200	8.83	14.13	4.40	4.72	7.87	9.88	9.71	13.55	13.42	19.78	19.46	29.89	29.56	48.03
6.35	250	11.04	17.67	5.51	5.91	9.88	12.37	12.17	17.00	16.80	24.77	24.38	37.40	37.01	60.11
7.62	300	13.25	21.20	6.63	7.12	11.88	14.86	14.63	20.41	20.18	29.76	29.27	44.95	44.49	72.18
8.89	350	15.46	24.73	7.78	8.33	13.85	17.36	17.13	23.82	23.56	34.74	34.19	52.46	51.94	84.25
10.16	400	17.67	28.27	8.89	9.55	15.85	19.88	19.59	27.23	26.94	39.70	39.11	59.97	59.42	96.36
12.70	500	22.08	35.34	11.12	11.94	19.85	24.87	24.51	34.09	33.69	49.67	48.95	75.03	74.34	120.51
15.24	600	26.50	42.40	13.39	14.37	23.82	29.86	29.43	40.95	40.45	59.65	58.79	90.09	89.27	144.65
17.78	700	30.92	49.47	15.65	16.77	27.82	34.88	34.35	47.77	47.21	69.62	68.60	105.12	104.20	168.80
20.32	800	35.34	56.53	17.88	19.19	-	-	-	-	-	-	-	-	-	-
22.86	900	39.75	63.60	20.14	21.59	-	-	-	-	-	-	-	-	-	-
25.40	1000	44.17	70.67	22.38	24.02	-	-	-	-	-	-	-	-	-	-

Projection lens Model No.		ET-C1U100		ET-C1W300		ET-C1W400 ET-C1W500 ET-C1S600 ET-C1T700	
Throw ratio ¹							
Projected image size		Height position (H)					
Diagonal (SD)		Min. (LW)	Max. (LT)				
m	inches						
1.78	70	3.09	4.95	0.00 - 3.08	0.00 - 3.08	-0.30 - 3.41	
2.03	80	3.53	5.65	0.00 - 3.54	0.00 - 3.54	-0.36 - 3.90	
2.29	90	3.98	6.36	0.00 - 3.97	0.00 - 3.97	-0.39 - 4.36	
2.54	100	4.42	7.07	0.00 - 4.43	0.00 - 4.43	-0.46 - 4.86	
3.05	120	5.30	8.48	0.00 - 5.32	0.00 - 5.32	-0.53 - 5.84	
3.81	150	6.62	10.60	0.00 - 6.63	0.00 - 6.63	-0.66 - 7.28	
5.08	200	8.83	14.13	0.00 - 8.83	0.00 - 8.83	-0.89 - 9.71	
6.35	250	11.04	17.67	0.00 - 11.06	0.00 - 11.06	-1.12 - 12.14	
7.62	300	13.25	21.20	0.00 - 13.26	0.00 - 13.26	-1.31 - 14.57	
8.89	350	15.46	24.73	0.00 - 15.45	0.00 - 15.45	-1.54 - 17.00	
10.16	400	17.67	28.27	0.00 - 17.68	0.00 - 17.68	-1.77 - 19.42	
12.70	500	22.08	35.34	0.00 - 22.08	0.00 - 22.08	-2.20 - 24.28	
15.24	600	26.50	42.40	0.00 - 26.51	0.00 - 26.51	-2.66 - 29.17	
17.78	700	30.92	49.47	0.00 - 30.91	0.00 - 30.91	-3.08 - 34.02	
20.32	800	35.34	56.53	0.00 - 35.34	-	-	
22.86	900	39.75	63.60	0.00 - 39.76	-	-	
25.40	1000	44.17	70.67	0.00 - 44.16	-	-	

1 The throw ratio is based on the value during projection with the projected image size of 2.54 m [100 in].

However, the throw ratio for ET-C1U100 is based on the value during projection with the projected image size of 3.81 m [150 in].

2 For ET-C1U100, fine text and images may not be displayed clearly during projection with the projected image size over 15.24 m [600 in].

Screen aspect ratio 16:9

Unit: meters

Projection lens Model No.		ET-C1U100 ²		ET-C1W300		ET-C1W400		ET-C1W500		ET-C1S600		ET-C1T700			
Throw ratio ¹		0.308 - 0.331:1		0.550 - 0.690:1		0.680 - 0.950:1		0.940 - 1.39:1		1.36 - 2.10:1		2.07 - 3.38:1			
Projected image size		Projection distance (L)													
Diagonal (SD)		Min. (LW)	Max. (LT)	Min. (LW)	Max. (LT)	Min. (LW)	Max. (LT)	Min. (LW)	Max. (LT)	Min. (LW)	Max. (LT)	Min. (LW)	Max. (LT)	Min. (LW)	Max. (LT)
m	inches														
1.78	70	0.872	1.550	0.46	0.49	0.84	1.06	1.04	1.46	1.45	2.14	2.09	3.24	3.18	5.21
2.03	80	0.996	1.771	0.53	0.57	0.97	1.22	1.19	1.68	1.66	2.45	2.40	3.71	3.65	5.97
2.29	90	1.121	1.992	0.60	0.64	1.09	1.37	1.35	1.89	1.87	2.76	2.71	4.18	4.12	6.73
2.54	100	1.245	2.214	0.67	0.72	1.22	1.53	1.50	2.10	2.08	3.08	3.01	4.65	4.58	7.48
3.05	120	1.494	2.657	0.81	0.87	1.47	1.84	1.81	2.53	2.51	3.70	3.63	5.59	5.52	9.00
3.81	150	1.868	3.321	1.02	1.10	1.84	2.31	2.27	3.18	3.14	4.64	4.55	7.01	6.92	11.27
5.08	200	2.491	4.428	1.38	1.48	2.47	3.09	3.05	4.25	4.20	6.20	6.09	9.36	9.26	15.05
6.35	250	3.113	5.535	1.73	1.85	3.09	3.88	3.82	5.32	5.26	7.76	7.63	11.72	11.60	18.83
7.62	300	3.736	6.641	2.08	2.23	3.72	4.66	4.59	6.39	6.32	9.32	9.17	14.08	13.94	22.62
8.89	350	4.358	7.748	2.43	2.61	4.34	5.44	5.36	7.46	7.38	10.88	10.71	16.44	16.28	26.40
10.16	400	4.981	8.855	2.78	2.99	4.97	6.23	6.13	8.54	8.44	12.44	12.26	18.79	18.62	30.18
12.70	500	6.226	11.069	3.49	3.74	6.22	7.79	7.68	10.68	10.56	15.56	15.34	23.51	23.29	37.75
15.24	600	7.472	13.283	4.19	4.50	7.47	9.36	9.22	12.82	12.67	18.69	18.42	28.22	27.97	45.32
17.78	700	8.717	15.497	4.90	5.26	8.72	10.92	10.76	14.97	14.79	21.81	21.50	32.94	32.65	52.88
20.32	800	9.962	17.710	5.60	6.01	-	-	-	-	-	-	-	-	-	-
22.86	900	11.207	19.924	6.31	6.77	-	-	-	-	-	-	-	-	-	-
25.40	1000	12.453	22.138	7.01	7.52	-	-	-	-	-	-	-	-	-	-

Projection lens Model No.		ET-C1U100		ET-C1W300		ET-C1W400 ET-C1W500 ET-C1S600 ET-C1T700	
Throw ratio ¹							
Projected image size		Height position (H)					
Diagonal (SD)		Min. (LW)	Max. (LT)				
m	inches						
1.78	70	0.872	1.550	-0.05 - 0.92	-0.05 - 0.92	-0.15 - 1.02	
2.03	80	0.996	1.771	-0.06 - 1.05	-0.06 - 1.05	-0.17 - 1.16	
2.29	90	1.121	1.992	-0.06 - 1.18	-0.06 - 1.18	-0.19 - 1.31	
2.54	100	1.245	2.214	-0.07 - 1.31	-0.07 - 1.31	-0.21 - 1.45	
3.05	120	1.494	2.657	-0.08 - 1.58	-0.08 - 1.58	-0.25 - 1.74	
3.81	150	1.868	3.321	-0.10 - 1.97	-0.10 - 1.97	-0.31 - 2.18	
5.08	200	2.491	4.428	-0.14 - 2.63	-0.14 - 2.63	-0.42 - 2.91	
6.35	250	3.113	5.535	-0.17 - 3.29	-0.17 - 3.29	-0.52 - 3.63	
7.62	300	3.736	6.641	-0.21 - 3.94	-0.21 - 3.94	-0.62 - 4.36	
8.89	350	4.358	7.748	-0.24 - 4.60	-0.24 - 4.60	-0.73 - 5.09	
10.16	400	4.981	8.855	-0.28 - 5.26	-0.28 - 5.26	-0.83 - 5.81	
12.70	500	6.226	11.069	-0.35 - 6.57	-0.35 - 6.57	-1.04 - 7.26	
15.24	600	7.472	13.283	-0.42 - 7.89	-0.42 - 7.89	-1.25 - 8.72	
17.78	700	8.717	15.497	-0.48 - 9.20	-0.48 - 9.20	-1.45 - 10.17	
20.32	800	9.962	17.710	-0.55 - 10.52	-	-	
22.86	900	11.207	19.924	-0.62 - 11.83	-	-	
25.40	1000	12.453	22.138	-0.69 - 13.14	-	-	

¹ The throw ratio is based on the value during projection with the projected image size of 2.54 m [100 in].

However, the throw ratio for ET-C1U100 is based on the value during projection with the projected image size of 3.81 m [150 in].

² For ET-C1U100, fine text and images may not be displayed clearly during projection with the projected image size over 15.24 m [600 in].

Screen aspect ratio 16:9

Unit: feet

Projection lens Model No.		ET-C1U100 ²	ET-C1W300	ET-C1W400	ET-C1W500	ET-C1S600	ET-C1T700								
Throw ratio ¹		0.308 - 0.331:1	0.550 - 0.690:1	0.680 - 0.950:1	0.940 - 1.39:1	1.36 - 2.10:1	2.07 - 3.38:1								
Projected image size		Projection distance (L)													
Diagonal (SD)		Min. (LW)	Max. (LT)	Min. (LW)	Max. (LT)	Min. (LW)	Max. (LT)	Min. (LW)	Max. (LT)	Min. (LW)	Max. (LT)	Min. (LW)	Max. (LT)	Min. (LW)	Max. (LT)
m	inches														
1.78	70	2.86	5.09	1.51	1.61	2.76	3.48	3.41	4.79	4.76	7.02	6.86	10.63	10.43	17.09
2.03	80	3.27	5.81	1.74	1.87	3.18	4.00	3.90	5.51	5.45	8.04	7.87	12.17	11.98	19.59
2.29	90	3.68	6.54	1.97	2.10	3.58	4.50	4.43	6.20	6.14	9.06	8.89	13.71	13.52	22.08
2.54	100	4.09	7.26	2.20	2.36	4.00	5.02	4.92	6.89	6.82	10.11	9.88	15.26	15.03	24.54
3.05	120	4.90	8.72	2.66	2.85	4.82	6.04	5.94	8.30	8.24	12.14	11.91	18.34	18.11	29.53
3.81	150	6.13	10.90	3.35	3.61	6.04	7.58	7.45	10.43	10.30	15.22	14.93	23.00	22.70	36.98
5.08	200	8.17	14.53	4.53	4.86	8.10	10.14	10.01	13.94	13.78	20.34	19.98	30.71	30.38	49.38
6.35	250	10.21	18.16	5.68	6.07	10.14	12.73	12.53	17.45	17.26	25.46	25.03	38.45	38.06	61.78
7.62	300	12.26	21.79	6.82	7.32	12.21	15.29	15.06	20.97	20.74	30.58	30.09	46.19	45.74	74.21
8.89	350	14.30	25.42	7.97	8.56	14.24	17.85	17.59	24.48	24.21	35.70	35.14	53.94	53.41	86.61
10.16	400	16.34	29.05	9.12	9.81	16.31	20.44	20.11	28.02	27.69	40.81	40.22	61.65	61.09	99.02
12.70	500	20.43	36.32	11.45	12.27	20.41	25.56	25.20	35.04	34.65	51.05	50.33	77.13	76.41	123.85
15.24	600	24.51	43.58	13.75	14.76	24.51	30.71	30.25	42.06	41.57	61.32	60.43	92.59	91.77	148.69
17.78	700	28.60	50.84	16.08	17.26	28.61	35.83	35.30	49.11	48.52	71.56	70.54	108.07	107.12	173.49
20.32	800	32.68	58.10	18.37	19.72	-	-	-	-	-	-	-	-	-	-
22.86	900	36.77	65.37	20.70	22.21	-	-	-	-	-	-	-	-	-	-
25.40	1000	40.86	72.63	23.00	24.67	-	-	-	-	-	-	-	-	-	-

Projection lens Model No.				ET-C1U100	ET-C1W300	ET-C1W400 ET-C1W500 ET-C1S600 ET-C1T700
Throw ratio ¹						
Projected image size				Height position (H)		
Diagonal (SD)		Min. (LW)	Max. (LT)			
m	inches					
1.78	70	2.86	5.09	-0.16 - 3.02	-0.16 - 3.02	-0.49 - 3.35
2.03	80	3.27	5.81	-0.20 - 3.45	-0.20 - 3.45	-0.56 - 3.81
2.29	90	3.68	6.54	-0.20 - 3.87	-0.20 - 3.87	-0.62 - 4.30
2.54	100	4.09	7.26	-0.23 - 4.30	-0.23 - 4.30	-0.69 - 4.76
3.05	120	4.90	8.72	-0.26 - 5.18	-0.26 - 5.18	-0.82 - 5.71
3.81	150	6.13	10.90	-0.33 - 6.46	-0.33 - 6.46	-1.02 - 7.15
5.08	200	8.17	14.53	-0.46 - 8.63	-0.46 - 8.63	-1.38 - 9.55
6.35	250	10.21	18.16	-0.56 - 10.79	-0.56 - 10.79	-1.71 - 11.91
7.62	300	12.26	21.79	-0.69 - 12.93	-0.69 - 12.93	-2.03 - 14.30
8.89	350	14.30	25.42	-0.79 - 15.09	-0.79 - 15.09	-2.40 - 16.70
10.16	400	16.34	29.05	-0.92 - 17.26	-0.92 - 17.26	-2.72 - 19.06
12.70	500	20.43	36.32	-1.15 - 21.56	-1.15 - 21.56	-3.41 - 23.82
15.24	600	24.51	43.58	-1.38 - 25.89	-1.38 - 25.89	-4.10 - 28.61
17.78	700	28.60	50.84	-1.58 - 30.18	-1.58 - 30.18	-4.76 - 33.37
20.32	800	32.68	58.10	-1.80 - 34.51	-	-
22.86	900	36.77	65.37	-2.03 - 38.81	-	-
25.40	1000	40.86	72.63	-2.26 - 43.11	-	-

¹ The throw ratio is based on the value during projection with the projected image size of 2.54 m [100 in].

However, the throw ratio for ET-C1U100 is based on the value during projection with the projected image size of 3.81 m [150 in].

² For ET-C1U100, fine text and images may not be displayed clearly during projection with the projected image size over 15.24 m [600 in].

Screen aspect ratio 4:3

Unit: meters

Projection lens Model No.			ET-C1U100 ²		ET-C1W300		ET-C1W400		ET-C1W500		ET-C1S600		ET-C1T700		
Throw ratio ¹			0.371 - 0.398:1		0.660 - 0.830:1		0.820 - 1.14:1		1.13 - 1.67:1		1.64 - 2.52:1		2.49 - 4.06:1		
Projected image size			Projection distance (L)												
Diagonal (SD)		Min. (LW)	Max. (LT)	Min. (LW)	Max. (LT)	Min. (LW)	Max. (LT)	Min. (LW)	Max. (LT)	Min. (LW)	Max. (LT)	Min. (LW)	Max. (LT)	Min. (LW)	Max. (LT)
m	inches														
1.78	70	1.067	1.422	0.51	0.55	0.93	1.17	1.15	1.61	1.60	2.36	2.31	3.57	3.51	5.75
2.03	80	1.219	1.626	0.59	0.63	1.07	1.34	1.32	1.85	1.83	2.71	2.65	4.09	4.03	6.58
2.29	90	1.372	1.829	0.66	0.71	1.21	1.51	1.49	2.09	2.07	3.05	2.99	4.61	4.54	7.42
2.54	100	1.524	2.032	0.74	0.80	1.34	1.69	1.66	2.32	2.30	3.39	3.33	5.13	5.06	8.25
3.05	120	1.829	2.438	0.90	0.96	1.62	2.03	2.00	2.79	2.77	4.08	4.00	6.17	6.09	9.92
3.81	150	2.286	3.048	1.13	1.21	2.03	2.55	2.51	3.50	3.47	5.11	5.02	7.73	7.63	12.42
5.08	200	3.048	4.064	1.52	1.63	2.72	3.41	3.36	4.68	4.63	6.83	6.72	10.32	10.21	16.59
6.35	250	3.810	5.080	1.91	2.05	3.41	4.27	4.21	5.86	5.80	8.55	8.42	12.92	12.79	20.75
7.62	300	4.572	6.096	2.29	2.46	4.10	5.14	5.06	7.05	6.96	10.27	10.11	15.51	15.36	24.92
8.89	350	5.334	7.112	2.68	2.88	4.79	6.00	5.91	8.23	8.13	11.99	11.81	18.11	17.94	29.09
10.16	400	6.096	8.128	3.07	3.29	5.47	6.86	6.76	9.41	9.30	13.71	13.51	20.71	20.51	33.25
12.70	500	7.620	10.160	3.85	4.13	6.85	8.59	8.46	11.77	11.63	17.15	16.90	25.90	25.66	41.59
15.24	600	9.144	12.192	4.62	4.96	8.23	10.31	10.16	14.13	13.96	20.59	20.29	31.09	30.82	49.92
17.78	700	10.668	14.224	5.40	5.79	9.60	12.04	11.86	16.49	16.30	24.03	23.68	36.28	35.97	58.26
20.32	800	12.192	16.256	6.18	6.62	-	-	-	-	-	-	-	-	-	-
22.86	900	13.716	18.288	6.95	7.46	-	-	-	-	-	-	-	-	-	-
25.40	1000	15.240	20.320	7.73	8.29	-	-	-	-	-	-	-	-	-	-

Projection lens Model No.			ET-C1U100	ET-C1W300	ET-C1W400 ET-C1W500 ET-C1S600 ET-C1T700	
Throw ratio ¹						
Projected image size			Height position (H)			
Diagonal (SD)		Min. (LW)				Max. (LT)
m	inches					
1.78	70	1.067	1.422	0.00 - 1.07	0.00 - 1.07	-0.11 - 1.17
2.03	80	1.219	1.626	0.00 - 1.22	0.00 - 1.22	-0.12 - 1.34
2.29	90	1.372	1.829	0.00 - 1.37	0.00 - 1.37	-0.14 - 1.51
2.54	100	1.524	2.032	0.00 - 1.52	0.00 - 1.52	-0.15 - 1.68
3.05	120	1.829	2.438	0.00 - 1.83	0.00 - 1.83	-0.18 - 2.01
3.81	150	2.286	3.048	0.00 - 2.29	0.00 - 2.29	-0.23 - 2.52
5.08	200	3.048	4.064	0.00 - 3.05	0.00 - 3.05	-0.31 - 3.35
6.35	250	3.810	5.080	0.00 - 3.81	0.00 - 3.81	-0.38 - 4.19
7.62	300	4.572	6.096	0.00 - 4.57	0.00 - 4.57	-0.46 - 5.03
8.89	350	5.334	7.112	0.00 - 5.33	0.00 - 5.33	-0.53 - 5.87
10.16	400	6.096	8.128	0.00 - 6.10	0.00 - 6.10	-0.61 - 6.71
12.70	500	7.620	10.160	0.00 - 7.62	0.00 - 7.62	-0.76 - 8.38
15.24	600	9.144	12.192	0.00 - 9.14	0.00 - 9.14	-0.91 - 10.06
17.78	700	10.668	14.224	0.00 - 10.67	0.00 - 10.67	-1.07 - 11.74
20.32	800	12.192	16.256	0.00 - 12.19	-	-
22.86	900	13.716	18.288	0.00 - 13.72	-	-
25.40	1000	15.240	20.320	0.00 - 15.24	-	-

1 The throw ratio is based on the value during projection with the projected image size of 2.54 m [100 in].

However, the throw ratio for ET-C1U100 is based on the value during projection with the projected image size of 3.81 m [150 in].

2 For ET-C1U100, fine text and images may not be displayed clearly during projection with the projected image size over 15.24 m [600 in].

Screen aspect ratio 4:3

Unit: feet

Projection lens Model No.		ET-C1U100 ²		ET-C1W300		ET-C1W400		ET-C1W500		ET-C1S600		ET-C1T700			
Throw ratio ¹		0.371 - 0.398:1		0.660 - 0.830:1		0.820 - 1.14:1		1.13 - 1.67:1		1.64 - 2.52:1		2.49 - 4.06:1			
Projected image size		Projection distance (L)													
Diagonal (SD)		Min. (LW)	Max. (LT)	Min. (LW)	Max. (LT)	Min. (LW)	Max. (LT)	Min. (LW)	Max. (LT)	Min. (LW)	Max. (LT)	Min. (LW)	Max. (LT)		
m	inches														
1.78	70	3.50	4.67	1.67	1.80	3.05	3.84	3.77	5.28	5.25	7.74	7.58	11.71	11.52	18.87
2.03	80	4.00	5.34	1.94	2.07	3.51	4.40	4.33	6.07	6.00	8.89	8.69	13.42	13.22	21.59
2.29	90	4.50	6.00	2.17	2.33	3.97	4.95	4.89	6.86	6.79	10.01	9.81	15.13	14.90	24.34
2.54	100	5.00	6.67	2.43	2.63	4.40	5.55	5.45	7.61	7.55	11.12	10.93	16.83	16.60	27.07
3.05	120	6.00	8.00	2.95	3.15	5.32	6.66	6.56	9.15	9.09	13.39	13.12	20.24	19.98	32.55
3.81	150	7.50	10.00	3.71	3.97	6.66	8.37	8.24	11.48	11.39	16.77	16.47	25.36	25.03	40.75
5.08	200	10.00	13.33	4.99	5.35	8.92	11.19	11.02	15.35	15.19	22.41	22.05	33.86	33.50	54.43
6.35	250	12.50	16.67	6.27	6.73	11.19	14.01	13.81	19.23	19.03	28.05	27.63	42.39	41.96	68.08
7.62	300	15.00	20.00	7.51	8.07	13.45	16.86	16.60	23.13	22.84	33.69	33.17	50.89	50.39	81.76
8.89	350	17.50	23.33	8.79	9.45	15.72	19.69	19.39	27.00	26.67	39.34	38.75	59.42	58.86	95.44
10.16	400	20.00	26.67	10.07	10.79	17.95	22.51	22.18	30.87	30.51	44.98	44.32	67.95	67.29	109.09
12.70	500	25.00	33.33	12.63	13.55	22.47	28.18	27.76	38.62	38.16	56.27	55.45	84.97	84.19	136.45
15.24	600	30.00	40.00	15.16	16.27	27.00	33.83	33.33	46.36	45.80	67.55	66.57	102.00	101.12	163.78
17.78	700	35.00	46.67	17.72	19.00	31.50	39.50	38.91	54.10	53.48	78.84	77.69	119.03	118.01	191.14
20.32	800	40.00	53.33	20.28	21.72	-	-	-	-	-	-	-	-	-	-
22.86	900	45.00	60.00	22.80	24.48	-	-	-	-	-	-	-	-	-	-
25.40	1000	50.00	66.67	25.36	27.20	-	-	-	-	-	-	-	-	-	-

Projection lens Model No.		ET-C1U100		ET-C1W300		ET-C1W400 ET-C1W500 ET-C1S600 ET-C1T700	
Throw ratio ¹							
Projected image size		Height position (H)					
Diagonal (SD)		Min. (LW)	Max. (LT)				
m	inches						
1.78	70	3.50	4.67	0.00 - 3.51	0.00 - 3.51	-0.36 - 3.84	
2.03	80	4.00	5.34	0.00 - 4.00	0.00 - 4.00	-0.39 - 4.40	
2.29	90	4.50	6.00	0.00 - 4.50	0.00 - 4.50	-0.46 - 4.95	
2.54	100	5.00	6.67	0.00 - 4.99	0.00 - 4.99	-0.49 - 5.51	
3.05	120	6.00	8.00	0.00 - 6.00	0.00 - 6.00	-0.59 - 6.59	
3.81	150	7.50	10.00	0.00 - 7.51	0.00 - 7.51	-0.76 - 8.27	
5.08	200	10.00	13.33	0.00 - 10.01	0.00 - 10.01	-1.02 - 10.99	
6.35	250	12.50	16.67	0.00 - 12.50	0.00 - 12.50	-1.25 - 13.75	
7.62	300	15.00	20.00	0.00 - 14.99	0.00 - 14.99	-1.51 - 16.50	
8.89	350	17.50	23.33	0.00 - 17.49	0.00 - 17.49	-1.74 - 19.26	
10.16	400	20.00	26.67	0.00 - 20.01	0.00 - 20.01	-2.00 - 22.01	
12.70	500	25.00	33.33	0.00 - 25.00	0.00 - 25.00	-2.49 - 27.49	
15.24	600	30.00	40.00	0.00 - 29.99	0.00 - 29.99	-2.99 - 33.01	
17.78	700	35.00	46.67	0.00 - 35.01	0.00 - 35.01	-3.51 - 38.52	
20.32	800	40.00	53.33	0.00 - 39.99	-	-	
22.86	900	45.00	60.00	0.00 - 45.01	-	-	
25.40	1000	50.00	66.67	0.00 - 50.00	-	-	

1 The throw ratio is based on the value during projection with the projected image size of 2.54 m [100 in].

However, the throw ratio for ET-C1U100 is based on the value during projection with the projected image size of 3.81 m [150 in].

2 For ET-C1U100, fine text and images may not be displayed clearly during projection with the projected image size over 15.24 m [600 in].

Calculation of the projection distance

To use a projected image size not listed in this manual, check the projected image size SD (m) and use the respective formula to calculate the value.

The unit of all the formulae is m. (Values obtained by the following calculation formulae contain a slight error.)
When calculating the value using image size designation (value in inches), multiply the value in inches by 0.0254 and substitute it into SD in the formula.

Screen aspect ratio 16:10

Unit: m

Projection lens Model No.	Throw ratio	Projection distance (L) formula	
		Min. (LW)	Max. (LT)
ET-C1U100	0.308 - 0.330 : 1	=0.2700 x SD - 0.0348	=0.2895 x SD - 0.0353
ET-C1W300	0.550 - 0.690 : 1	=0.4787 x SD - 0.0322	=0.5998 x SD - 0.0376
ET-C1W400	0.680 - 0.950 : 1	=0.5913 x SD - 0.0416	=0.8212 x SD - 0.0389
ET-C1W500	0.940 - 1.39 : 1	=0.8114 x SD - 0.0344	=1.1958 x SD - 0.0448
ET-C1S600	1.36 - 2.10 : 1	=1.1800 x SD - 0.0668	=1.8057 x SD - 0.0631
ET-C1T700	2.07 - 3.38 : 1	=1.7915 x SD - 0.0929	=2.8985 x SD - 0.0835

Screen aspect ratio 16:9

Unit: m

Projection lens Model No.	Throw ratio	Projection distance (L) formula	
		Min. (LW)	Max. (LT)
ET-C1U100	0.308 - 0.331 : 1	=0.2775 x SD - 0.0348	=0.2975 x SD - 0.0353
ET-C1W300	0.550 - 0.690 : 1	=0.4920 x SD - 0.0322	=0.6165 x SD - 0.0376
ET-C1W400	0.680 - 0.950 : 1	=0.6078 x SD - 0.0416	=0.8440 x SD - 0.0389
ET-C1W500	0.940 - 1.39 : 1	=0.8339 x SD - 0.0344	=1.2291 x SD - 0.0448
ET-C1S600	1.36 - 2.10 : 1	=1.2128 x SD - 0.0668	=1.8559 x SD - 0.0631
ET-C1T700	2.07 - 3.38 : 1	=1.8413 x SD - 0.0929	=2.9791 x SD - 0.0835

Screen aspect ratio 4:3

Unit: m

Projection lens Model No.	Throw ratio	Projection distance (L) formula	
		Min. (LW)	Max. (LT)
ET-C1U100	0.371 - 0.398 : 1	=0.3057 x SD - 0.0348	=0.3277 x SD - 0.0353
ET-C1W300	0.660 - 0.830 : 1	=0.5420 x SD - 0.0322	=0.6791 x SD - 0.0376
ET-C1W400	0.820 - 1.14 : 1	=0.6694 x SD - 0.0416	=0.9297 x SD - 0.0389
ET-C1W500	1.13 - 1.67 : 1	=0.9185 x SD - 0.0344	=1.3538 x SD - 0.0448
ET-C1S600	1.64 - 2.52 : 1	=1.3358 x SD - 0.0668	=2.0442 x SD - 0.0631
ET-C1T700	2.49 - 4.06 : 1	=2.0282 x SD - 0.0929	=3.2813 x SD - 0.0835

Adjustment range by the lens position shift (optical shift)

Based on the standard projection position using the optical axis shift function, the projection position can be adjusted in the range shown in the following figure.

Following figure shows the adjustment range when the projector is installed on the floor.

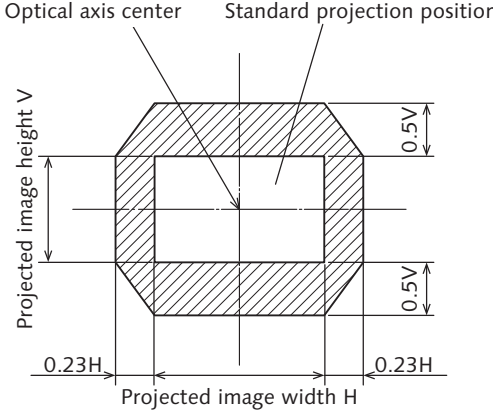
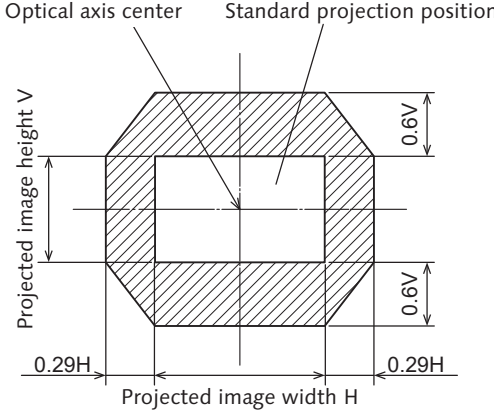
Projection lens Model No.	When ET-C1U100, ET-C1W300 is mounted.	When Standard zoom lens, ET-C1W400, ET-C1W500, ET-C1S600, ET-C1T700 is mounted.
Lens shift range	 <p>Optical axis center Standard projection position</p> <p>Projected image height V</p> <p>0.5V</p> <p>0.5V</p> <p>0.23H 0.23H</p> <p>Projected image width H</p>	 <p>Optical axis center Standard projection position</p> <p>Projected image height V</p> <p>0.6V</p> <p>0.6V</p> <p>0.29H 0.29H</p> <p>Projected image width H</p>

- Optimal image can be achieved by installing the projector squarely in front of the screen and adjusting the lens shift lever to center.

[SCREEN ADJUSTMENT] projection range

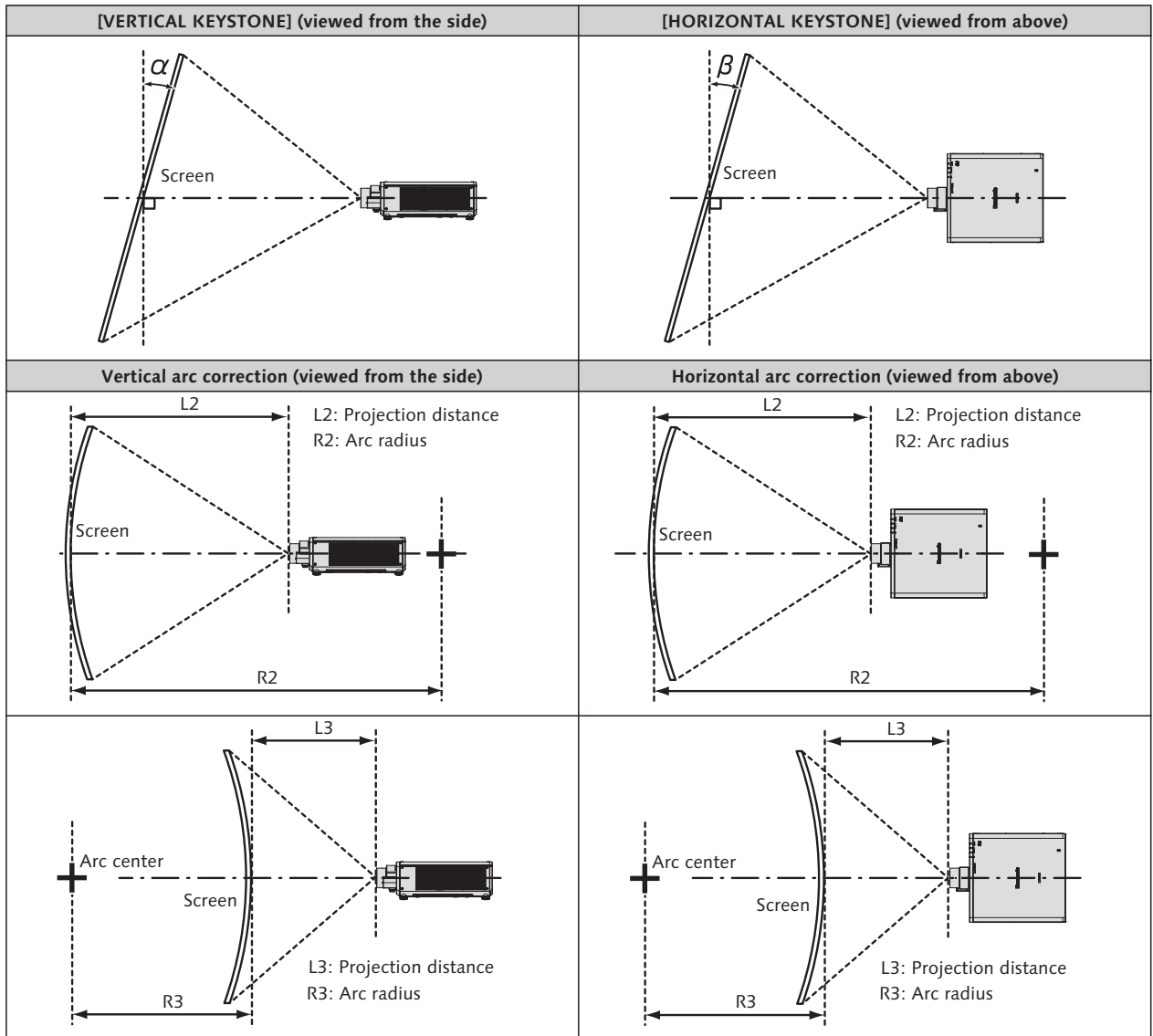

Projection lens Model No.	Only [KEYSTONE] used ¹		[KEYSTONE] and [CURVED CORRECTION] used together				Only [CURVED CORRECTION] used	
	Vertical keystone correction angle α (°)	Horizontal keystone correction angle β (°)	Vertical keystone correction angle α (°)	Horizontal keystone correction angle β (°)	Min. value of R2/L2	Min. value of R3/L3	Min. value of R2/L2	Min. value of R3/L3
ET-C1U100	±5	±3	-	-	-	-	-	-
ET-C1W300	±10	±5	-	-	-	-	-	-
ET-C1W400	±16	±10	-	-	-	-	-	-
ET-C1W500	±22	±15	±8	±8	1.3	3.3	0.8	1.9
ET-C1S600	±40	±40	±20	±15	1.3	3.3	0.8	1.9
ET-C1T700	±40	±40	±20	±15	0.9	2.0	0.5	1.1

¹ When [VERTICAL KEYSTONE] and [HORIZONTAL KEYSTONE] are used simultaneously, correction cannot be made exceeding total of 55°.

Note

- When [GEOMETRY] is used, the focus of the entire screen may be lost as correction increases.
- Make the curved screen a circular arc shape with one part of a perfect circle removed.
- Adjustment range of the [GEOMETRY] items may not match the listed projection range depending on the projection lens. Use this projector within the projection range, otherwise the correction may not work.

Installable angle

Install the projector at an angle within the range shown below.

FULL 360-degree projection

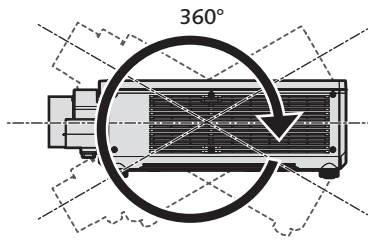

Vertical 360-deg.

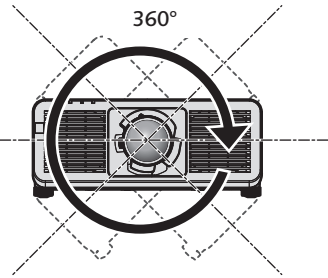

Horizontal 360-deg.

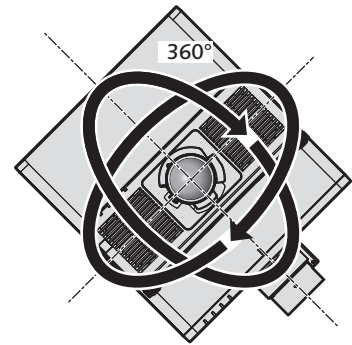

Tilting 360-deg.
(Vertical and Horizontal combination)

Notes on projector placement and operation

- Do not stack projectors on top of each other.
- Do not use the projector supporting it by the top.

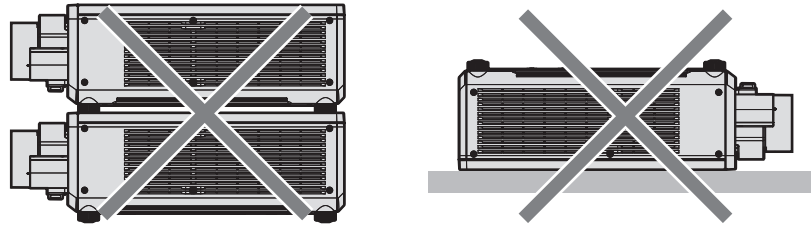

- Do not block the intake/exhaust vents of the projector.
- Prevent hot and cool air from the air conditioning system to blow directly to the intake/exhaust vents of the projector.

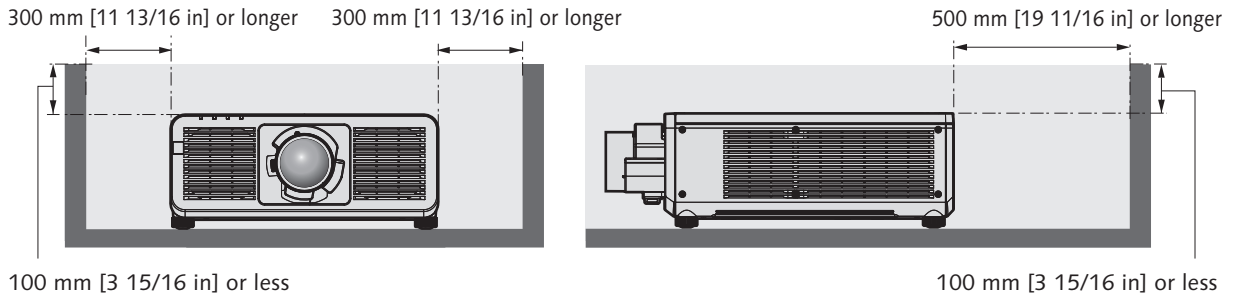

- Do not install the projector in a confined space. When installing the projector in a confined space, provide air conditioning or ventilation separately. Exhaust heat may accumulate when the ventilation is not enough, triggering the protection circuit of the projector.

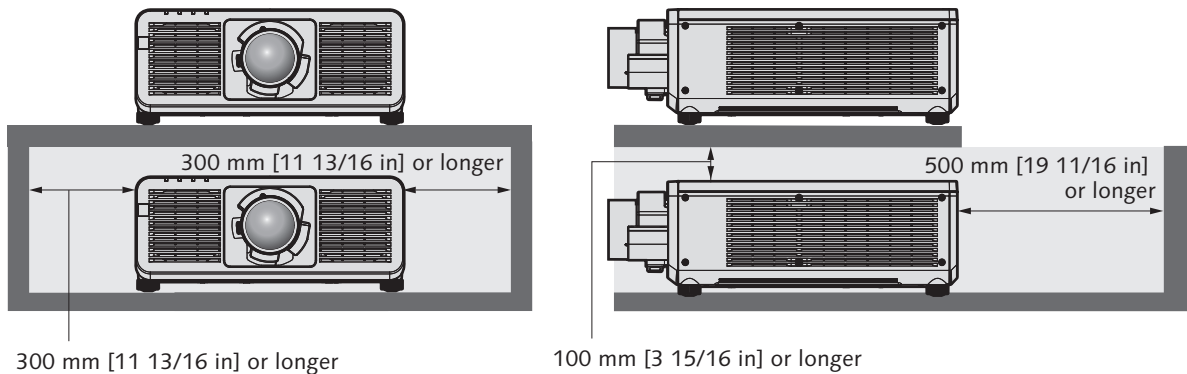

- When installing and fixing the projector on a ceiling or wall using a mount, make sure that the fixing screw or power cord does not come in contact with the metal section inside the ceiling or wall. Failure to observe this may result in electric shocks.
- Panasonic Connect Co., Ltd. takes no responsibility for any damage to the product caused by an inappropriate choice of location for installing the projector, even if the warranty period of the product has not expired.
- Immediately remove the product that is not in use anymore by asking a qualified technician.

List of compatible signals

The following table specifies the video signals compatible with the projector.

For details of SDI signal, refer to "List of single link SDI compatible signals". "List of quad link SDI compatible signals".

This projector supports the signal with ✓ in the compatible signal column.

- The content of the compatible signal column is as follows.

-V: Video signal -C: Computer signal

Signal Type	Signal name (SIGNAL FORMAT)	Resolution (Dots)	Scanning freq.		Dot clock freq. (MHz)	Compatible signal		
			Horizontal (kHz)	Vertical (Hz)		HDMI	DisplayPort	DIGITAL LINK ¹
V	480/60p	720 x 480	31.5	59.9	27.0	✓	–	✓
	576/50p	720 x 576	31.3	50.0	27.0	✓	–	✓
	720/60p	1280 x 720	45.0	60.0 ²	74.3	✓	✓	✓
	720/50p	1280 x 720	37.5	50.0	74.3	✓	✓	✓
	720/120p	1280 x 720	90.0	120.0 ²	148.5	✓	✓	✓
	1080/60i	1920 x 1080i	33.8	60.0 ²	74.3	✓	–	✓
	1080/50i	1920 x 1080i	28.1	50.0	74.3	✓	–	✓
	1080/24p	1920 x 1080	27.0	24.0 ²	74.3	✓	✓	✓
	1080/24sF	1920 x 1080i	27.0	48.0 ²	74.3	✓	–	✓
	1080/25p	1920 x 1080	28.1	25.0	74.3	✓	✓	✓
	1080/30p	1920 x 1080	33.8	30.0 ²	74.3	✓	✓	✓
	1080/60p	1920 x 1080	67.5	60.0 ²	148.5	✓	✓	✓
	1080/50p	1920 x 1080	56.3	50.0	148.5	✓	✓	✓
	1080/120p	1920 x 1080	135.0	120.0 ²	297.0	✓	✓	✓
	2K/24p	2048 x 1080	27.0	24.0 ²	74.3	✓	✓	✓
	2K/25p	2048 x 1080	28.1	25.0	74.3	✓	✓	✓
	2K/30p	2048 x 1080	33.8	30.0 ²	74.3	✓	✓	✓
	2K/48p	2048 x 1080	54.0	48.0 ²	148.5	✓	✓	✓
	2K/60p	2048 x 1080	67.5	60.0 ²	148.5	✓	✓	✓
	2K/50p	2048 x 1080	56.3	50.0	148.5	✓	✓	✓
	2560 x 1080/60p	2560 x 1080	66.0	60.0 ²	198.0	✓	✓	✓
	2560 x 1080/50p	2560 x 1080	56.3	50.0	185.6	✓	✓	✓
	3840 x 2160/24p	3840 x 2160	54.0	24.0 ²	297.0	✓	✓	✓
	3840 x 2160/25p	3840 x 2160	56.3	25.0	297.0	✓	✓	✓
	3840 x 2160/30p	3840 x 2160	67.5	30.0 ²	297.0	✓	✓	✓
	3840 x 2160/60p	3840 x 2160	135.0	60.0 ²	297.0	✓ ³	–	✓ ³
		3840 x 2160	135.0	60.0 ²	594.0	✓	✓	–
	3840 x 2160/50p	3840 x 2160	112.5	50.0	297.0	✓ ³	–	✓ ³
		3840 x 2160	112.5	50.0	594.0	✓	✓	–
	4096 x 2160/24p	4096 x 2160	54.0	24.0 ²	297.0	✓	✓	✓
	4096 x 2160/25p	4096 x 2160	56.3	25.0	297.0	✓	✓	✓
	4096 x 2160/30p	4096 x 2160	67.5	30.0 ²	297.0	✓	✓	✓
	4096 x 2160/60p	4096 x 2160	135.0	60.0 ²	297.0	✓ ³	–	✓ ³
4096 x 2160		135.0	60.0 ²	594.0	✓	✓	–	
4096 x 2160/50p	4096 x 2160	112.5	50.0	297.0	✓ ³	–	✓ ³	
	4096 x 2160	112.5	50.0	594.0	✓	✓	–	
C	640 x 480/60	640 x 480	31.5	59.9	25.2	✓	✓	✓
	1024 x 768/50	1024 x 768	39.6	50.0	51.9	✓	✓	✓
	1024 x 768/60	1024 x 768	48.4	60.0	65.0	✓	✓	✓
	1280 x 800/50	1280 x 800	41.3	50.0	68.0	✓	✓	✓
	1280 x 800/60	1280 x 800	49.7	59.8	83.5	✓	✓	✓
	1280 x 1024/50	1280 x 1024	52.4	50.0	88.0	✓	–	✓
	1280 x 1024/60	1280 x 1024	64.0	60.0	108.0	✓	–	✓
	1366 x 768/50	1366 x 768	39.6	49.9	69.0	✓	–	✓
	1366 x 768/60	1366 x 768	47.7	59.8	85.5	✓	–	✓
	1400 x 1050/50	1400 x 1050	54.1	50.0	99.9	✓	✓	✓
	1400 x 1050/60	1400 x 1050	65.2	60.0	122.6	✓	✓	✓
	1440 x 900/50	1440 x 900	46.3	49.9	86.8	✓	–	✓
	1440 x 900/60	1440 x 900	55.9	59.9	106.5	✓	–	✓
	1600 x 900/50	1600 x 900	46.4	49.9	96.5	✓	✓	✓
	1600 x 900/60	1600 x 900	55.9	60.0	119.0	✓	✓	✓
	1600 x 1200/50	1600 x 1200	61.8	49.9	131.5	✓	✓	✓
	1600 x 1200/60	1600 x 1200	75.0	60.0	162.0	✓	✓	✓
	1680 x 1050/50	1680 x 1050	54.1	50.0	119.5	✓	–	✓
	1680 x 1050/60	1680 x 1050	65.3	60.0	146.3	✓	–	✓
	1920 x 1080/240	1920 x 1080	291.6	240.0	583.2	–	–	–
	1920 x 1200/50	1920 x 1200	61.8	49.9	158.3	✓	✓	✓
	1920 x 1200/60RB	1920 x 1200 ⁴	74.0	60.0	154.0	✓	✓	✓
	2560 x 1440/50	2560 x 1440	74.1	50.0	256.3	✓	✓	✓
2560 x 1440/60	2560 x 1440 ⁴	88.8	60.0	241.5	✓	✓	✓	
2560 x 1600/50	2560 x 1600	82.4	50.0	286.0	✓	✓	✓	

Signal Type	Signal name (SIGNAL FORMAT)	Resolution (Dots)	Scanning freq.		Dot clock freq. (MHz)	Compatible signal		
			Horizontal (kHz)	Vertical (Hz)		HDMI	DisplayPort	DIGITAL LINK ¹
C	2560 x 1600/60	2560 x 1600 ⁴	98.7	60.0	268.5	✓	✓	✓
	3440 x 1440/50	3440 x 1440 ⁴	73.7	50.0	259.4	✓	✓	–
	3440 x 1440/60	3440 x 1440 ⁴	88.9	60.0	312.8	✓	✓	–
	3840 x 2400/30	3840 x 2400 ⁴	73.0	30.0	286.2	✓	✓	✓
	3840 x 2400/50	3840 x 2400 ⁴	122.9	50.0	481.6	✓	✓	–
	3840 x 2400/60	3840 x 2400 ⁴	148.1	60.0	592.5	✓	✓	–

- 1 Requires TY-SB01DL Interface Board for DIGITAL LINK.
- 2 The signal with 1/1.001x vertical scanning frequency is also supported.
- 3 YPbPr 4:2:0 format only
- 4 VESA CVT-RB (Reduced Blanking)-compliant

Note

- A signal with a different resolution, including SDI signal, is displayed converted to the number of display dots. The number of display dots is as follows: 1920 x 1200
- The "i" at the end of the resolution indicates an interlaced signal.
- When interlaced signals are connected, flickering may occur on the projected image.

List of Plug and play compatible signals

The following table specifies the video signals compatible with plug and play.

Signal with ✓ in the plug and play compatible signal column is the signal described in the EDID (extended display identification data) of the projector.

For the signal without ✓ in the plug and play compatible signal column, the resolution may not be selected on the computer even if the projector is supporting it.

Signal name (SIGNAL FORMAT)	Resolution (Dots)	Scanning freq.		Dot clock freq. (MHz)	Plug and play compatible signal								
		Horizontal (kHz)	Vertical (Hz)		HDMI			DisplayPort			DIGITAL LINK ¹		
					4K/60p ²	4K/30p	2K	4K/60p ²	4K/30p	2K	4K/60p	4K/30p ³	2K
480/60p	720 x 480	31.5	59.9	27.0	✓	✓	✓	–	–	–	✓	✓	✓
576/50p	720 x 576	31.3	50.0	27.0	✓	✓	✓	–	–	–	✓	✓	✓
720/60p	1280 x 720	45.0	60.0 ⁴	74.3	✓	✓	✓	✓	✓	✓	✓	✓	✓
720/50p	1280 x 720	37.5	50.0	74.3	✓	✓	✓	✓	✓	✓	✓	✓	✓
720/120p	1280 x 720	90.0	120.0 ⁴	148.5	–	–	–	–	–	–	–	–	–
1080/60i	1920 x 1080i	33.8	60.0 ⁴	74.3	✓	✓	✓	–	–	–	✓	✓	✓
1080/50i	1920 x 1080i	28.1	50.0	74.3	✓	✓	✓	–	–	–	✓	✓	✓
1080/24p	1920 x 1080	27.0	24.0 ⁴	74.3	✓	✓	✓	✓	✓	✓	✓	✓	✓
1080/24sF	1920 x 1080i	27.0	48.0 ⁴	74.3	–	–	–	–	–	–	–	–	–
1080/25p	1920 x 1080	28.1	25.0	74.3	✓	✓	✓	✓	✓	✓	✓	✓	✓
1080/30p	1920 x 1080	33.8	30.0 ⁴	74.3	✓	✓	✓	✓	✓	✓	✓	✓	✓
1080/60p	1920 x 1080	67.5	60.0 ⁴	148.5	✓	✓	✓	✓	✓	✓	✓	✓	✓
1080/50p	1920 x 1080	56.3	50.0	148.5	✓	✓	✓	✓	✓	✓	✓	✓	✓
1080/120p	1920 x 1080	135.0	120.0 ⁴	297.0	✓	✓	–	✓	✓	–	✓	✓	–
2K/24p	2048 x 1080	27.0	24.0 ⁴	74.3	–	–	–	–	–	–	–	–	–
2K/25p	2048 x 1080	28.1	25.0	74.3	–	–	–	–	–	–	–	–	–
2K/30p	2048 x 1080	33.8	30.0 ⁴	74.3	–	–	–	–	–	–	–	–	–
2K/48p	2048 x 1080	54.0	48.0 ⁴	148.5	–	–	–	–	–	–	–	–	–
2K/60p	2048 x 1080	67.5	60.0 ⁴	148.5	–	–	–	–	–	–	–	–	–
2K/50p	2048 x 1080	56.3	50.0	148.5	–	–	–	–	–	–	–	–	–
2560 x 1080/60p	2560 x 1080	66.0	60.0 ⁴	198.0	✓	✓	–	✓	✓	–	✓	✓	–
2560 x 1080/50p	2560 x 1080	56.3	50.0	185.6	✓	✓	–	✓	✓	–	✓	✓	–
3840 x 2160/24p	3840 x 2160	54.0	24.0 ⁴	297.0	✓	✓	–	✓	✓	–	✓	✓	–
3840 x 2160/25p	3840 x 2160	56.3	25.0	297.0	✓	✓	–	✓	✓	–	✓	✓	–
3840 x 2160/30p	3840 x 2160	67.5	30.0 ⁴	297.0	✓	✓	–	✓	✓	–	✓	✓	–
3840 x 2160/60p	3840 x 2160	135.0	60.0 ⁴	297.0	✓ ⁵	–	–	–	–	–	✓ ⁵	–	–
	3840 x 2160	135.0	60.0 ⁴	594.0	✓	–	–	✓	–	–	–	–	–
3840 x 2160/50p	3840 x 2160	112.5	50.0	297.0	✓ ⁵	–	–	–	–	–	✓ ⁵	–	–
	3840 x 2160	112.5	50.0	594.0	✓	–	–	✓	–	–	–	–	–
4096 x 2160/24p	4096 x 2160	54.0	24.0 ⁴	297.0	✓	✓	–	✓	✓	–	✓	✓	–
4096 x 2160/25p	4096 x 2160	56.3	25.0	297.0	✓	✓	–	✓	✓	–	✓	✓	–
4096 x 2160/30p	4096 x 2160	67.5	30.0 ⁴	297.0	✓	✓	–	✓	✓	–	✓	✓	–
4096 x 2160/60p	4096 x 2160	135.0	60.0 ⁴	297.0	✓ ⁵	–	–	–	–	–	✓ ⁵	–	–
	4096 x 2160	135.0	60.0 ⁴	594.0	✓	–	–	✓	–	–	–	–	–
4096 x 2160/50p	4096 x 2160	112.5	50.0	297.0	✓ ⁵	–	–	–	–	–	✓ ⁵	–	–
	4096 x 2160	112.5	50.0	594.0	✓	–	–	✓	–	–	–	–	–
640 x 480/60	640 x 480	31.5	59.9	25.2	✓	✓	✓	✓	✓	✓	✓	✓	✓
1024 x 768/50	1024 x 768	39.6	50.0	51.9	–	–	–	–	–	–	–	–	–
1024 x 768/60	1024 x 768	48.4	60.0	65.0	✓	✓	✓	✓	✓	✓	✓	✓	✓
1280 x 800/50	1280 x 800	41.3	50.0	68.0	–	–	–	–	–	–	–	–	–
1280 x 800/60	1280 x 800	49.7	59.8	83.5	–	–	–	–	–	–	–	–	–
1280 x 1024/50	1280 x 1024	52.4	50.0	88.0	–	–	–	–	–	–	–	–	–
1280 x 1024/60	1280 x 1024	64.0	60.0	108.0	–	–	–	–	–	–	–	–	–
1366 x 768/50	1366 x 768	39.6	49.9	69.0	–	–	–	–	–	–	–	–	–
1366 x 768/60	1366 x 768	47.7	59.8	85.5	–	–	–	–	–	–	–	–	–
1400 x 1050/50	1400 x 1050	54.1	50.0	99.9	–	–	–	–	–	–	–	–	–
1400 x 1050/60	1400 x 1050	65.2	60.0	122.6	✓	✓	✓	✓	✓	✓	✓	✓	✓
1440 x 900/50	1440 x 900	46.3	49.9	86.8	–	–	–	–	–	–	–	–	–
1440 x 900/60	1440 x 900	55.9	59.9	106.5	–	–	–	–	–	–	–	–	–
1600 x 900/50	1600 x 900	46.4	49.9	96.5	–	–	–	–	–	–	–	–	–
1600 x 900/60	1600 x 900	55.9	60.0	119.0	✓	✓	✓	✓	✓	✓	✓	✓	✓
1600 x 1200/50	1600 x 1200	61.8	49.9	131.5	–	–	–	–	–	–	–	–	–
1600 x 1200/60	1600 x 1200	75.0	60.0	162.0	✓	✓	✓	✓	✓	✓	✓	✓	✓
1680 x 1050/50	1680 x 1050	54.1	50.0	119.5	–	–	–	–	–	–	–	–	–
1680 x 1050/60	1680 x 1050	65.3	60.0	146.3	–	–	–	–	–	–	–	–	–
1920 x 1080/240	1920 x 1080	291.6	240.0	583.2	–	–	–	–	–	–	–	–	–
1920 x 1200/50	1920 x 1200	61.8	49.9	158.3	–	–	–	–	–	–	–	–	–
1920 x 1200/60RB	1920 x 1200 ⁶	74.0	60.0	154.0	✓	✓	✓	✓	✓	✓	✓	✓	✓
2560 x 1440/50	2560 x 1440	74.1	50.0	256.3	–	–	–	–	–	–	–	–	–
2560 x 1440/60	2560 x 1440 ⁶	88.8	60.0	241.5	–	–	–	–	–	–	–	–	–
2560 x 1600/50	2560 x 1600	82.4	50.0	286.0	–	–	–	–	–	–	–	–	–

Signal name (SIGNAL FORMAT)	Resolution (Dots)	Scanning freq.		Dot clock freq. (MHz)	Plug and play compatible signal								
		Horizontal (kHz)	Vertical (Hz)		HDMI			DisplayPort			DIGITAL LINK ¹		
					4K/60p ²	4K/30p	2K	4K/60p ²	4K/30p	2K	4K/60p	4K/30p ³	2K
2560 x 1600/60	2560 x 1600 ⁶	98.7	60.0	268.5	✓	✓	–	✓	✓	–	✓	✓	–
3440 x 1440/50	3440 x 1440 ⁶	73.7	50.0	259.4	–	–	–	–	–	–	–	–	–
3440 x 1440/60	3440 x 1440 ⁶	88.9	60.0	312.8	–	–	–	–	–	–	–	–	–
3840 x 2400/30	3840 x 2400 ⁶	73.0	30.0	286.2	–	–	–	–	–	–	–	–	–
3840 x 2400/50	3840 x 2400 ⁶	122.9	50.0	481.6	–	–	–	–	–	–	–	–	–
3840 x 2400/60	3840 x 2400 ⁶	148.1	60.0	592.5	✓	–	–	✓	–	–	–	–	–

- 1 Requires TY-SB01DL Interface Board for DIGITAL LINK.
- 2 4K/60p indicates 4K/60p/SDR and 4K/60p/HDR.
- 3 4K/30p indicates 4K/30p/SDR and 4K/30p/HDR.
- 4 The signal with 1/1.001x vertical scanning frequency is also supported.
- 5 YPbPr 4:2:0 format only
- 6 VESA CVT-RB (Reduced Blanking)-compliant

Note

- A signal with a different resolution, including SDI signal, is displayed converted to the number of display dots.
The number of display dots is as follows: 1920 x 1200
- The "i" at the end of the resolution indicates an interlaced signal.
- When interlaced signals are connected, flickering may occur on the projected image.

List of Single link SDI compatible signals

The following table specifies the single link SDI signals that the projector can project.

This is supported when the optional 12G-SDI Terminal Board (Model No.: TY-SB01QS) or the optional Function Board for 12G-SDI Optical (Model No.: TY-SB01FB) is installed in the slot.

- The content of the 4K division column is as follows.
-IL: Interleave (transmission format of 2-Sample Interleave Division)
- The content of the signal type column is as follows.
-V: Video signal

Signal Type	Signal name (SIGNAL FORMAT)	Resolution (Dots)	Scanning freq.		Dot clock freq. (MHz)	4K division	Format	Color format	Sampling
			Horizontal (kHz)	Vertical (Hz)					
V	720/60p ¹	1280 x 720	45.0	60.0 ²	74.3	–	HD-SDI	YPbPr	4:2:2 10bit
	720/50p ¹	1280 x 720	37.5	50.0	74.3	–	HD-SDI	YPbPr	4:2:2 10bit
	1080/60i	1920 x 1080i	33.8	60.0 ²	74.3	–	HD-SDI	YPbPr	4:2:2 10bit
		1920 x 1080i	33.8	60.0 ²	74.3	–	3G-SDI Level-A	RGB	4:4:4 10bit
		1920 x 1080i	33.8	60.0 ²	74.3	–	3G-SDI Level-B	RGB	4:4:4 10bit
		1920 x 1080i	33.8	60.0 ²	74.3	–	3G-SDI Level-A	RGB	4:4:4 12bit
		1920 x 1080i	33.8	60.0 ²	74.3	–	3G-SDI Level-B	RGB	4:4:4 12bit
	1080/50i	1920 x 1080i	28.1	50.0	74.3	–	HD-SDI	YPbPr	4:2:2 10bit
		1920 x 1080i	28.1	50.0	74.3	–	3G-SDI Level-A	RGB	4:4:4 10bit
		1920 x 1080i	28.1	50.0	74.3	–	3G-SDI Level-B	RGB	4:4:4 10bit
		1920 x 1080i	28.1	50.0	74.3	–	3G-SDI Level-A	RGB	4:4:4 12bit
		1920 x 1080i	28.1	50.0	74.3	–	3G-SDI Level-B	RGB	4:4:4 12bit
	1080/24p	1920 x 1080	27.0	24.0 ²	74.3	–	HD-SDI	YPbPr	4:2:2 10bit
		1920 x 1080	27.0	24.0 ²	74.3	–	3G-SDI Level-A	RGB	4:4:4 10bit
		1920 x 1080	27.0	24.0 ²	74.3	–	3G-SDI Level-B	RGB	4:4:4 10bit
		1920 x 1080	27.0	24.0 ²	74.3	–	3G-SDI Level-A	RGB	4:4:4 12bit
		1920 x 1080	27.0	24.0 ²	74.3	–	3G-SDI Level-B	RGB	4:4:4 12bit
	1080/24sF ¹	1920 x 1080i	27.0	48.0 ²	74.3	–	HD-SDI	YPbPr	4:2:2 10bit
		1920 x 1080i	27.0	48.0 ²	74.3	–	3G-SDI Level-A	RGB	4:4:4 10bit
		1920 x 1080i	27.0	48.0 ²	74.3	–	3G-SDI Level-B	RGB	4:4:4 10bit
		1920 x 1080i	27.0	48.0 ²	74.3	–	3G-SDI Level-A	RGB	4:4:4 12bit
		1920 x 1080i	27.0	48.0 ²	74.3	–	3G-SDI Level-B	RGB	4:4:4 12bit
	1080/25p	1920 x 1080	28.1	25.0	74.3	–	HD-SDI	YPbPr	4:2:2 10bit
		1920 x 1080	28.1	25.0	74.3	–	3G-SDI Level-A	RGB	4:4:4 10bit
		1920 x 1080	28.1	25.0	74.3	–	3G-SDI Level-B	RGB	4:4:4 10bit
		1920 x 1080	28.1	25.0	74.3	–	3G-SDI Level-A	RGB	4:4:4 12bit
		1920 x 1080	28.1	25.0	74.3	–	3G-SDI Level-B	RGB	4:4:4 12bit
	1080/30p	1920 x 1080	33.8	30.0 ²	74.3	–	HD-SDI	YPbPr	4:2:2 10bit
		1920 x 1080	33.8	30.0 ²	74.3	–	3G-SDI Level-A	RGB	4:4:4 10bit
		1920 x 1080	33.8	30.0 ²	74.3	–	3G-SDI Level-B	RGB	4:4:4 10bit
		1920 x 1080	33.8	30.0 ²	74.3	–	3G-SDI Level-A	RGB	4:4:4 12bit
		1920 x 1080	33.8	30.0 ²	74.3	–	3G-SDI Level-B	RGB	4:4:4 12bit
	1080/60p	1920 x 1080	67.5	60.0 ²	148.5	–	3G-SDI Level-A	YPbPr	4:2:2 10bit
		1920 x 1080	67.5	60.0 ²	148.5	–	3G-SDI Level-B	YPbPr	4:2:2 10bit
	1080/50p	1920 x 1080	56.3	50.0	148.5	–	3G-SDI Level-A	YPbPr	4:2:2 10bit
		1920 x 1080	56.3	50.0	148.5	–	3G-SDI Level-B	YPbPr	4:2:2 10bit
	2K/24p	2048 x 1080	27.0	24.0 ²	74.3	–	3G-SDI Level-A	RGB	4:4:4 10bit
		2048 x 1080	27.0	24.0 ²	74.3	–	3G-SDI Level-B	RGB	4:4:4 10bit
		2048 x 1080	27.0	24.0 ²	74.3	–	3G-SDI Level-A	RGB	4:4:4 12bit
		2048 x 1080	27.0	24.0 ²	74.3	–	3G-SDI Level-B	RGB	4:4:4 12bit
2K/48p ¹	2048 x 1080	54.0	48.0 ²	148.5	–	3G-SDI Level-A	YPbPr	4:2:2 10bit	
	2048 x 1080	54.0	48.0 ²	148.5	–	3G-SDI Level-B	YPbPr	4:2:2 10bit	
2K/25p	2048 x 1080	28.1	25.0	74.3	–	3G-SDI Level-A	RGB	4:4:4 10bit	
	2048 x 1080	28.1	25.0	74.3	–	3G-SDI Level-B	RGB	4:4:4 10bit	
	2048 x 1080	28.1	25.0	74.3	–	3G-SDI Level-A	RGB	4:4:4 12bit	
	2048 x 1080	28.1	25.0	74.3	–	3G-SDI Level-B	RGB	4:4:4 12bit	
2K/30p	2048 x 1080	33.8	30.0 ²	74.3	–	3G-SDI Level-A	RGB	4:4:4 10bit	
	2048 x 1080	33.8	30.0 ²	74.3	–	3G-SDI Level-B	RGB	4:4:4 10bit	
	2048 x 1080	33.8	30.0 ²	74.3	–	3G-SDI Level-A	RGB	4:4:4 12bit	
	2048 x 1080	33.8	30.0 ²	74.3	–	3G-SDI Level-B	RGB	4:4:4 12bit	
2K/60p	2048 x 1080	67.5	60.0 ²	148.5	–	3G-SDI Level-A	YPbPr	4:2:2 10bit	
	2048 x 1080	67.5	60.0 ²	148.5	–	3G-SDI Level-B	YPbPr	4:2:2 10bit	
2K/50p	2048 x 1080	56.3	50.0	148.5	–	3G-SDI Level-A	YPbPr	4:2:2 10bit	
	2048 x 1080	56.3	50.0	148.5	–	3G-SDI Level-B	YPbPr	4:2:2 10bit	
3840 x 2160/24p	3840 x 2160	54.0	24.0 ²	297.0	IL	12G-SDI Type 1	YPbPr	4:2:2 12bit	
	3840 x 2160	54.0	24.0 ²	297.0	IL	12G-SDI Type 1	YPbPr	4:4:4 10bit	
	3840 x 2160	54.0	24.0 ²	297.0	IL	12G-SDI Type 1	YPbPr	4:4:4 12bit	
	3840 x 2160	54.0	24.0 ²	297.0	IL	12G-SDI Type 1	RGB	4:4:4 10bit	
	3840 x 2160	54.0	24.0 ²	297.0	IL	12G-SDI Type 1	RGB	4:4:4 12bit	

Signal Type	Signal name (SIGNAL FORMAT)	Resolution (Dots)	Scanning freq.		Dot clock freq. (MHz)	4K division	Format	Color format	Sampling
			Horizontal (kHz)	Vertical (Hz)					
V	3840 x 2160/25p	3840 x 2160	56.3	25.0	297.0	IL	12G-SDI Type 1	YPbPr	4:2:2 12bit
		3840 x 2160	56.3	25.0	297.0	IL	12G-SDI Type 1	YPbPr	4:4:4 10bit
		3840 x 2160	56.3	25.0	297.0	IL	12G-SDI Type 1	YPbPr	4:4:4 12bit
		3840 x 2160	56.3	25.0	297.0	IL	12G-SDI Type 1	RGB	4:4:4 10bit
	3840 x 2160/30p	3840 x 2160	67.5	30.0 ²	297.0	IL	12G-SDI Type 1	YPbPr	4:2:2 12bit
		3840 x 2160	67.5	30.0 ²	297.0	IL	12G-SDI Type 1	YPbPr	4:4:4 10bit
		3840 x 2160	67.5	30.0 ²	297.0	IL	12G-SDI Type 1	YPbPr	4:4:4 12bit
		3840 x 2160	67.5	30.0 ²	297.0	IL	12G-SDI Type 1	RGB	4:4:4 10bit
	3840 x 2160/60p	3840 x 2160	135.0	60.0 ²	594.0	IL	12G-SDI Type 1	YPbPr	4:2:2 10bit
	3840 x 2160/50p	3840 x 2160	112.5	50.0	594.0	IL	12G-SDI Type 1	YPbPr	4:2:2 10bit
	4096 x 2160/24p	4096 x 2160	54.0	24.0 ²	297.0	IL	12G-SDI Type 1	YPbPr	4:2:2 12bit
		4096 x 2160	54.0	24.0 ²	297.0	IL	12G-SDI Type 1	YPbPr	4:4:4 10bit
		4096 x 2160	54.0	24.0 ²	297.0	IL	12G-SDI Type 1	YPbPr	4:4:4 12bit
		4096 x 2160	54.0	24.0 ²	297.0	IL	12G-SDI Type 1	RGB	4:4:4 10bit
		4096 x 2160	54.0	24.0 ²	297.0	IL	12G-SDI Type 1	RGB	4:4:4 12bit
	4096 x 2160/25p	4096 x 2160	56.3	25.0	297.0	IL	12G-SDI Type 1	YPbPr	4:2:2 12bit
		4096 x 2160	56.3	25.0	297.0	IL	12G-SDI Type 1	YPbPr	4:4:4 10bit
		4096 x 2160	56.3	25.0	297.0	IL	12G-SDI Type 1	YPbPr	4:4:4 12bit
		4096 x 2160	56.3	25.0	297.0	IL	12G-SDI Type 1	RGB	4:4:4 10bit
	4096 x 2160/30p	4096 x 2160	67.5	30.0 ²	297.0	IL	12G-SDI Type 1	YPbPr	4:2:2 12bit
		4096 x 2160	67.5	30.0 ²	297.0	IL	12G-SDI Type 1	YPbPr	4:4:4 10bit
		4096 x 2160	67.5	30.0 ²	297.0	IL	12G-SDI Type 1	YPbPr	4:4:4 12bit
		4096 x 2160	67.5	30.0 ²	297.0	IL	12G-SDI Type 1	RGB	4:4:4 10bit
		4096 x 2160	67.5	30.0 ²	297.0	IL	12G-SDI Type 1	RGB	4:4:4 12bit
	4096 x 2160/60p	4096 x 2160	135.0	60.0 ²	594.0	IL	12G-SDI Type 1	YPbPr	4:2:2 10bit
	4096 x 2160/50p	4096 x 2160	112.5	50.0	594.0	IL	12G-SDI Type 1	YPbPr	4:2:2 10bit

1 This is supported when the optional Function Board for 12G-SDI Optical (Model No.: TY-SB01FB) is installed in the slot.

2 The signal with 1/1.001x vertical scanning frequency is also supported.

List of Quad link SDI compatible signals

The following table specifies the dual signal SDI signals that the projector can project.

Requires TY-SB01QS Interface Board for 12G-SDI Input.

- The content of the 4K division column is as follows.
-SQ: Square (transmission format of Square Division) -IL: Interleave (transmission format of 2-Sample Interleave Division)
- The content of the signal type column is as follows.
-V: Video signal

Signal Type	Signal name (SIGNAL FORMAT)	Resolution (Dots)	Scanning freq.		Dot clock freq. (MHz)	4K division	Format	Color format	Sampling
			Horizontal (kHz)	Vertical (Hz)					
V	3840 x 2160/24p	3840 x 2160	54.0	24.0 ¹	297.0	SQ	HD-SDI	YPbPr	4:2:2 10bit
		3840 x 2160	54.0	24.0 ¹	297.0	SQ	3G-SDI Level-A	YPbPr	4:2:2 12bit
		3840 x 2160	54.0	24.0 ¹	297.0	IL	3G-SDI Level-A	YPbPr	4:2:2 12bit
		3840 x 2160	54.0	24.0 ¹	297.0	SQ	3G-SDI Level-B	YPbPr	4:2:2 12bit
		3840 x 2160	54.0	24.0 ¹	297.0	IL	3G-SDI Level-B	YPbPr	4:2:2 12bit
		3840 x 2160	54.0	24.0 ¹	297.0	SQ	3G-SDI Level-A	YPbPr	4:4:4 10bit
		3840 x 2160	54.0	24.0 ¹	297.0	IL	3G-SDI Level-A	YPbPr	4:4:4 10bit
		3840 x 2160	54.0	24.0 ¹	297.0	SQ	3G-SDI Level-B	YPbPr	4:4:4 10bit
		3840 x 2160	54.0	24.0 ¹	297.0	IL	3G-SDI Level-B	YPbPr	4:4:4 10bit
		3840 x 2160	54.0	24.0 ¹	297.0	SQ	3G-SDI Level-A	YPbPr	4:4:4 12bit
		3840 x 2160	54.0	24.0 ¹	297.0	IL	3G-SDI Level-A	YPbPr	4:4:4 12bit
		3840 x 2160	54.0	24.0 ¹	297.0	SQ	3G-SDI Level-B	YPbPr	4:4:4 12bit
		3840 x 2160	54.0	24.0 ¹	297.0	IL	3G-SDI Level-B	YPbPr	4:4:4 12bit
		3840 x 2160	54.0	24.0 ¹	297.0	SQ	3G-SDI Level-A	RGB	4:4:4 10bit
		3840 x 2160	54.0	24.0 ¹	297.0	IL	3G-SDI Level-A	RGB	4:4:4 10bit
		3840 x 2160	54.0	24.0 ¹	297.0	SQ	3G-SDI Level-B	RGB	4:4:4 10bit
		3840 x 2160	54.0	24.0 ¹	297.0	IL	3G-SDI Level-B	RGB	4:4:4 10bit
		3840 x 2160/25p	3840 x 2160	56.3	25.0	297.0	SQ	HD-SDI	YPbPr
	3840 x 2160		56.3	25.0	297.0	SQ	3G-SDI Level-A	YPbPr	4:2:2 12bit
	3840 x 2160		56.3	25.0	297.0	IL	3G-SDI Level-A	YPbPr	4:2:2 12bit
	3840 x 2160		56.3	25.0	297.0	SQ	3G-SDI Level-B	YPbPr	4:2:2 12bit
	3840 x 2160		56.3	25.0	297.0	IL	3G-SDI Level-B	YPbPr	4:2:2 12bit
	3840 x 2160		56.3	25.0	297.0	SQ	3G-SDI Level-A	YPbPr	4:4:4 10bit
	3840 x 2160		56.3	25.0	297.0	IL	3G-SDI Level-A	YPbPr	4:4:4 10bit
	3840 x 2160		56.3	25.0	297.0	SQ	3G-SDI Level-B	YPbPr	4:4:4 10bit
	3840 x 2160		56.3	25.0	297.0	IL	3G-SDI Level-B	YPbPr	4:4:4 10bit
	3840 x 2160		56.3	25.0	297.0	SQ	3G-SDI Level-A	YPbPr	4:4:4 12bit
	3840 x 2160		56.3	25.0	297.0	IL	3G-SDI Level-A	YPbPr	4:4:4 12bit
	3840 x 2160		56.3	25.0	297.0	SQ	3G-SDI Level-B	YPbPr	4:4:4 12bit
	3840 x 2160		56.3	25.0	297.0	IL	3G-SDI Level-B	YPbPr	4:4:4 12bit
	3840 x 2160		56.3	25.0	297.0	SQ	3G-SDI Level-A	RGB	4:4:4 10bit
	3840 x 2160		56.3	25.0	297.0	IL	3G-SDI Level-A	RGB	4:4:4 10bit
	3840 x 2160		56.3	25.0	297.0	SQ	3G-SDI Level-B	RGB	4:4:4 10bit
	3840 x 2160		56.3	25.0	297.0	IL	3G-SDI Level-B	RGB	4:4:4 10bit
	3840 x 2160/30p		3840 x 2160	67.5	30.0 ¹	297.0	SQ	HD-SDI	YPbPr
		3840 x 2160	67.5	30.0 ¹	297.0	SQ	3G-SDI Level-A	YPbPr	4:2:2 12bit
		3840 x 2160	67.5	30.0 ¹	297.0	IL	3G-SDI Level-A	YPbPr	4:2:2 12bit
		3840 x 2160	67.5	30.0 ¹	297.0	SQ	3G-SDI Level-B	YPbPr	4:2:2 12bit
		3840 x 2160	67.5	30.0 ¹	297.0	IL	3G-SDI Level-B	YPbPr	4:2:2 12bit
		3840 x 2160	67.5	30.0 ¹	297.0	SQ	3G-SDI Level-A	YPbPr	4:4:4 10bit
		3840 x 2160	67.5	30.0 ¹	297.0	IL	3G-SDI Level-A	YPbPr	4:4:4 10bit
		3840 x 2160	67.5	30.0 ¹	297.0	SQ	3G-SDI Level-B	YPbPr	4:4:4 10bit
3840 x 2160		67.5	30.0 ¹	297.0	IL	3G-SDI Level-B	YPbPr	4:4:4 10bit	
3840 x 2160		67.5	30.0 ¹	297.0	SQ	3G-SDI Level-A	YPbPr	4:4:4 12bit	
3840 x 2160		67.5	30.0 ¹	297.0	IL	3G-SDI Level-A	YPbPr	4:4:4 12bit	
3840 x 2160		67.5	30.0 ¹	297.0	SQ	3G-SDI Level-B	YPbPr	4:4:4 12bit	
3840 x 2160		67.5	30.0 ¹	297.0	IL	3G-SDI Level-B	YPbPr	4:4:4 12bit	
3840 x 2160		67.5	30.0 ¹	297.0	SQ	3G-SDI Level-A	RGB	4:4:4 10bit	
3840 x 2160		67.5	30.0 ¹	297.0	IL	3G-SDI Level-A	RGB	4:4:4 10bit	
3840 x 2160		67.5	30.0 ¹	297.0	SQ	3G-SDI Level-B	RGB	4:4:4 10bit	
3840 x 2160	67.5	30.0 ¹	297.0	IL	3G-SDI Level-B	RGB	4:4:4 10bit		

PT-REZ10B/REZ10LB/REZ10W/REZ10LW

Signal Type	Signal name (SIGNAL FORMAT)	Resolution (Dots)	Scanning freq.		Dot clock freq. (MHz)	4K division	Format	Color format	Sampling	
			Horizontal (kHz)	Vertical (Hz)						
V	3840 x 2160/30p	3840 x 2160	67.5	30.0 ¹	297.0	SQ	3G-SDI Level-A	RGB	4:4:4 12bit	
		3840 x 2160	67.5	30.0 ¹	297.0	IL	3G-SDI Level-A	RGB	4:4:4 12bit	
		3840 x 2160	67.5	30.0 ¹	297.0	SQ	3G-SDI Level-B	RGB	4:4:4 12bit	
		3840 x 2160	67.5	30.0 ¹	297.0	IL	3G-SDI Level-B	RGB	4:4:4 12bit	
	3840 x 2160/60p	3840 x 2160	135.0	60.0 ¹	594.0	SQ	3G-SDI Level-A	YPbPr	4:2:2 10bit	
		3840 x 2160	135.0	60.0 ¹	594.0	IL	3G-SDI Level-A	YPbPr	4:2:2 10bit	
		3840 x 2160	135.0	60.0 ¹	594.0	SQ	3G-SDI Level-B	YPbPr	4:2:2 10bit	
	3840 x 2160/50p	3840 x 2160	112.5	50.0	594.0	SQ	3G-SDI Level-A	YPbPr	4:2:2 10bit	
		3840 x 2160	112.5	50.0	594.0	IL	3G-SDI Level-A	YPbPr	4:2:2 10bit	
		3840 x 2160	112.5	50.0	594.0	SQ	3G-SDI Level-B	YPbPr	4:2:2 10bit	
		3840 x 2160	112.5	50.0	594.0	IL	3G-SDI Level-B	YPbPr	4:2:2 10bit	
	4096 x 2160/24p	4096 x 2160	54.0	24.0 ¹	297.0	SQ	HD-SDI	YPbPr	4:2:2 10bit	
		4096 x 2160	54.0	24.0 ¹	297.0	SQ	3G-SDI Level-A	YPbPr	4:2:2 12bit	
		4096 x 2160	54.0	24.0 ¹	297.0	IL	3G-SDI Level-A	YPbPr	4:2:2 12bit	
		4096 x 2160	54.0	24.0 ¹	297.0	SQ	3G-SDI Level-B	YPbPr	4:2:2 12bit	
		4096 x 2160	54.0	24.0 ¹	297.0	IL	3G-SDI Level-B	YPbPr	4:2:2 12bit	
		4096 x 2160	54.0	24.0 ¹	297.0	SQ	3G-SDI Level-A	YPbPr	4:4:4 10bit	
		4096 x 2160	54.0	24.0 ¹	297.0	IL	3G-SDI Level-A	YPbPr	4:4:4 10bit	
		4096 x 2160	54.0	24.0 ¹	297.0	SQ	3G-SDI Level-B	YPbPr	4:4:4 10bit	
		4096 x 2160	54.0	24.0 ¹	297.0	IL	3G-SDI Level-B	YPbPr	4:4:4 10bit	
		4096 x 2160	54.0	24.0 ¹	297.0	SQ	3G-SDI Level-A	YPbPr	4:4:4 12bit	
		4096 x 2160	54.0	24.0 ¹	297.0	IL	3G-SDI Level-A	YPbPr	4:4:4 12bit	
		4096 x 2160	54.0	24.0 ¹	297.0	SQ	3G-SDI Level-B	YPbPr	4:4:4 12bit	
		4096 x 2160	54.0	24.0 ¹	297.0	IL	3G-SDI Level-B	YPbPr	4:4:4 12bit	
		4096 x 2160	54.0	24.0 ¹	297.0	SQ	3G-SDI Level-A	RGB	4:4:4 10bit	
		4096 x 2160	54.0	24.0 ¹	297.0	IL	3G-SDI Level-A	RGB	4:4:4 10bit	
		4096 x 2160	54.0	24.0 ¹	297.0	SQ	3G-SDI Level-B	RGB	4:4:4 10bit	
		4096 x 2160	54.0	24.0 ¹	297.0	IL	3G-SDI Level-B	RGB	4:4:4 10bit	
		4096 x 2160/25p	4096 x 2160	56.3	25.0	297.0	SQ	HD-SDI	YPbPr	4:2:2 10bit
			4096 x 2160	56.3	25.0	297.0	SQ	3G-SDI Level-A	YPbPr	4:2:2 12bit
			4096 x 2160	56.3	25.0	297.0	IL	3G-SDI Level-A	YPbPr	4:2:2 12bit
	4096 x 2160		56.3	25.0	297.0	SQ	3G-SDI Level-B	YPbPr	4:2:2 12bit	
	4096 x 2160		56.3	25.0	297.0	IL	3G-SDI Level-B	YPbPr	4:2:2 12bit	
	4096 x 2160		56.3	25.0	297.0	SQ	3G-SDI Level-A	YPbPr	4:4:4 10bit	
	4096 x 2160		56.3	25.0	297.0	IL	3G-SDI Level-A	YPbPr	4:4:4 10bit	
	4096 x 2160		56.3	25.0	297.0	SQ	3G-SDI Level-B	YPbPr	4:4:4 10bit	
	4096 x 2160		56.3	25.0	297.0	IL	3G-SDI Level-B	YPbPr	4:4:4 10bit	
	4096 x 2160		56.3	25.0	297.0	SQ	3G-SDI Level-A	YPbPr	4:4:4 12bit	
	4096 x 2160		56.3	25.0	297.0	IL	3G-SDI Level-A	YPbPr	4:4:4 12bit	
	4096 x 2160		56.3	25.0	297.0	SQ	3G-SDI Level-B	YPbPr	4:4:4 12bit	
	4096 x 2160		56.3	25.0	297.0	IL	3G-SDI Level-B	YPbPr	4:4:4 12bit	
	4096 x 2160		56.3	25.0	297.0	SQ	3G-SDI Level-A	RGB	4:4:4 10bit	
	4096 x 2160		56.3	25.0	297.0	IL	3G-SDI Level-A	RGB	4:4:4 10bit	
	4096 x 2160		56.3	25.0	297.0	SQ	3G-SDI Level-B	RGB	4:4:4 10bit	
	4096 x 2160		56.3	25.0	297.0	IL	3G-SDI Level-B	RGB	4:4:4 10bit	
	4096 x 2160/30p		4096 x 2160	67.5	30.0 ¹	297.0	SQ	HD-SDI	YPbPr	4:2:2 10bit
			4096 x 2160	67.5	30.0 ¹	297.0	SQ	3G-SDI Level-A	YPbPr	4:2:2 12bit
			4096 x 2160	67.5	30.0 ¹	297.0	IL	3G-SDI Level-A	YPbPr	4:2:2 12bit
		4096 x 2160	67.5	30.0 ¹	297.0	SQ	3G-SDI Level-B	YPbPr	4:2:2 12bit	
		4096 x 2160	67.5	30.0 ¹	297.0	IL	3G-SDI Level-B	YPbPr	4:2:2 12bit	
		4096 x 2160	67.5	30.0 ¹	297.0	SQ	3G-SDI Level-A	YPbPr	4:4:4 10bit	
		4096 x 2160	67.5	30.0 ¹	297.0	IL	3G-SDI Level-A	YPbPr	4:4:4 10bit	
		4096 x 2160	67.5	30.0 ¹	297.0	SQ	3G-SDI Level-B	YPbPr	4:4:4 10bit	
		4096 x 2160	67.5	30.0 ¹	297.0	IL	3G-SDI Level-B	YPbPr	4:4:4 10bit	
4096 x 2160		67.5	30.0 ¹	297.0	SQ	3G-SDI Level-A	YPbPr	4:4:4 12bit		
4096 x 2160		67.5	30.0 ¹	297.0	IL	3G-SDI Level-A	YPbPr	4:4:4 12bit		
4096 x 2160		67.5	30.0 ¹	297.0	SQ	3G-SDI Level-B	YPbPr	4:4:4 12bit		
4096 x 2160		67.5	30.0 ¹	297.0	IL	3G-SDI Level-B	YPbPr	4:4:4 12bit		
4096 x 2160		67.5	30.0 ¹	297.0	SQ	3G-SDI Level-A	RGB	4:4:4 10bit		

Signal Type	Signal name (SIGNAL FORMAT)	Resolution (Dots)	Scanning freq.		Dot clock freq. (MHz)	4K division	Format	Color format	Sampling
			Horizontal (kHz)	Vertical (Hz)					
V	4096 x 2160/30p	4096 x 2160	67.5	30.0 ¹	297.0	IL	3G-SDI Level-A	RGB	4:4:4 10bit
		4096 x 2160	67.5	30.0 ¹	297.0	SQ	3G-SDI Level-B	RGB	4:4:4 10bit
		4096 x 2160	67.5	30.0 ¹	297.0	IL	3G-SDI Level-B	RGB	4:4:4 10bit
		4096 x 2160	67.5	30.0 ¹	297.0	SQ	3G-SDI Level-A	RGB	4:4:4 12bit
		4096 x 2160	67.5	30.0 ¹	297.0	IL	3G-SDI Level-A	RGB	4:4:4 12bit
		4096 x 2160	67.5	30.0 ¹	297.0	SQ	3G-SDI Level-B	RGB	4:4:4 12bit
	4096 x 2160/60p	4096 x 2160	135.0	60.0 ¹	594.0	SQ	3G-SDI Level-A	YPbPr	4:2:2 10bit
		4096 x 2160	135.0	60.0 ¹	594.0	IL	3G-SDI Level-A	YPbPr	4:2:2 10bit
		4096 x 2160	135.0	60.0 ¹	594.0	SQ	3G-SDI Level-B	YPbPr	4:2:2 10bit
		4096 x 2160	135.0	60.0 ¹	594.0	IL	3G-SDI Level-B	YPbPr	4:2:2 10bit
	4096 x 2160/50p	4096 x 2160	112.5	50.0	594.0	SQ	3G-SDI Level-A	YPbPr	4:2:2 10bit
		4096 x 2160	112.5	50.0	594.0	IL	3G-SDI Level-A	YPbPr	4:2:2 10bit
		4096 x 2160	112.5	50.0	594.0	SQ	3G-SDI Level-B	YPbPr	4:2:2 10bit
		4096 x 2160	112.5	50.0	594.0	IL	3G-SDI Level-B	YPbPr	4:2:2 10bit

1 The signal with 1/1.001x vertical scanning frequency is also supported.