



INSTALLATION MANUAL

Projector Mounting Bracket

For 1.5-Inch NPT Threaded Pipes

Model: QG-PRO-PM-50-W



Scan the QR Code™ below for more info about this product:



CAUTION!

Do not exceed the maximum rated weight specified. Otherwise, serious injury or property damage may occur.



1-Year Limited Warranty

Version: Sep 2023

NOTE Please read the entire installation manual before you start installation and assembly.

WARNING

- Only begin installing your QualGear product once you have read and understood all the instructions and warnings in this installation manual. If you have any questions regarding the instructions, please contact QualGear customer support via email at support@qualgear.com.
- This product should only be installed by someone of good mechanical aptitude who has experience with basic building construction and fully understands these instructions.
- This product was designed to be installed and utilized only as specified in this manual. Improper installation of this product may cause damage or serious injury. QualGear is not liable for the improper use or installation of its products.
- Ensure that the supporting surface will safely support the combined load of the equipment and all attached hardware and components.
- Always use an assistant or mechanical lifting equipment to lift and position the equipment safely.
- Tighten screws firmly, but do not over-tighten. Over-tightening can damage the items, greatly reducing their holding power.
- All QualGear products are intended for indoor use only, and any outdoor use voids the limited warranty.
- If mounting to wooden studs, make sure that mounting screws are anchored into the center of the studs. Use of an edge-to-edge stud finder is highly recommended.
- Never exceed the maximum rated weight specified in this manual.
- All bolts and screws must be used at the designated points in the installation instructions to prevent property damage and personal injury.
- Do not install near air conditioner vents or where there is excessive dust or smoke.
- When drilling holes in the ceiling, it is very important to take care of electrical cables, water, or gas pipes in the ceiling.

Parts Checklist

IMPORTANT: Before starting installation, please ensure all parts in this checklist are included. If any parts are missing or damaged, please contact support@qualgear.com for replacement parts, and do not start assembly and installation until you receive all the parts.

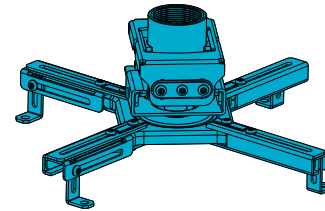

Projector Bracket (x1)
A



M6 x 8mm Screw (x1)
B



4mm Allen Key (x1)
C

Hardware Package



M3 x 8mm Screws (x4)
M-A



M4 x 10mm Screws (x4)
M-B



M5 x 10mm Screws (x4)
M-C



M6 x 10mm Screws (x4)
M-D



M4 x 25mm Screws (x4)
M-E



M6 x 25mm Screws (x4)
M-F



D3 Washers (x4)
M-G



D4 Washers (x4)
M-H



D5 Washers (x4)
M-I



D6 Washers (x4)
M-J



5mm Spacers (x8)
M-K

1 Disassemble the Projector Bracket

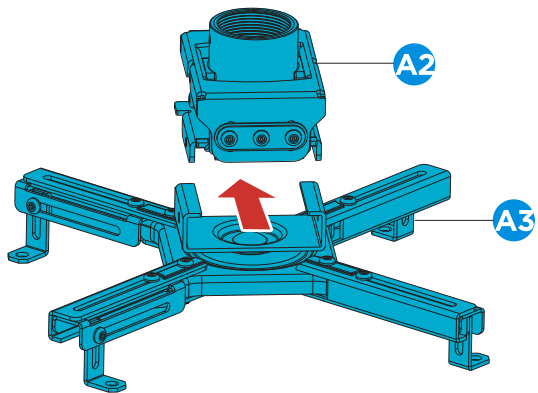
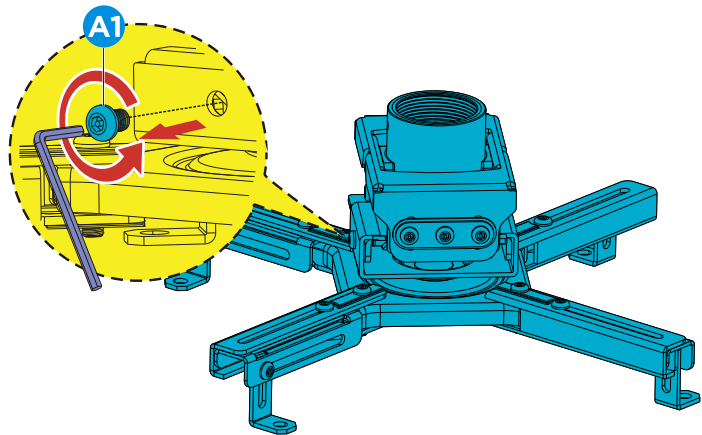

2 Connect the Adapter Bracket to the Extension Column

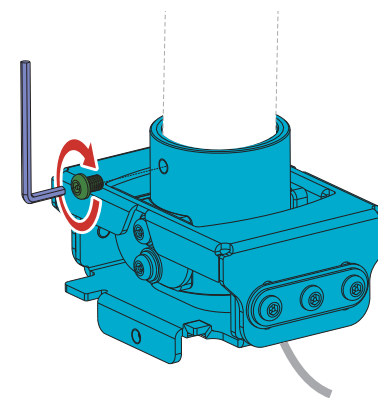
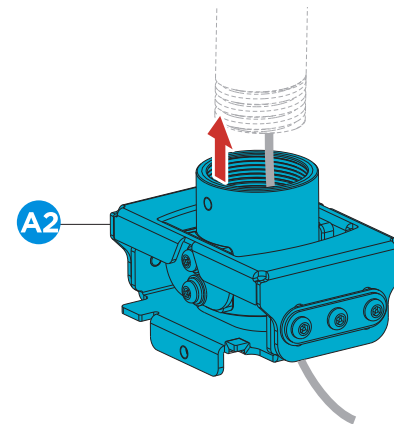

3 Attach the Adapter Bracket to the Projector

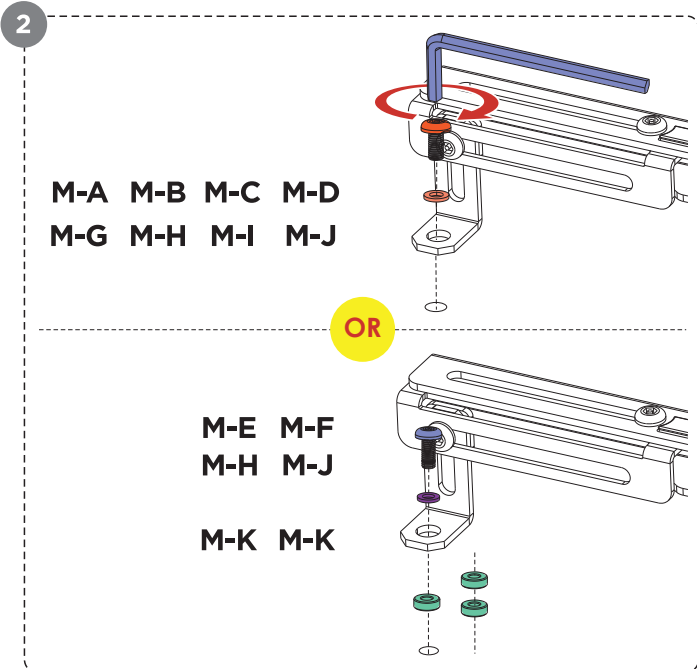
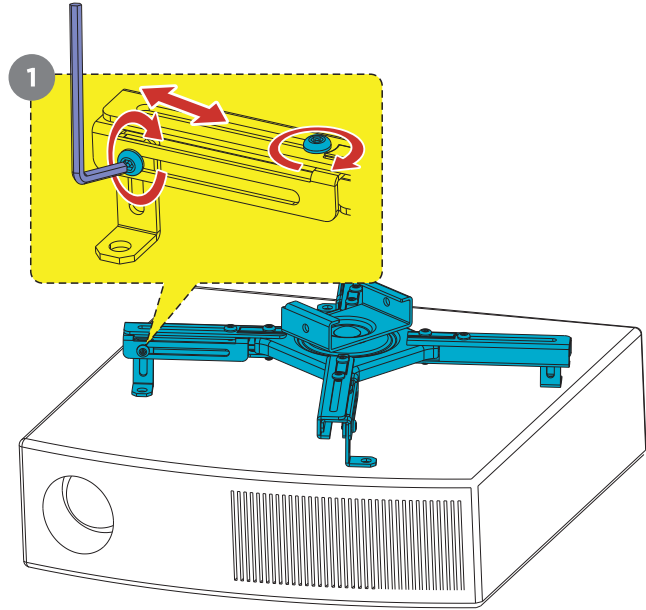

4 Connect the Projector Assembly to the Extension Column

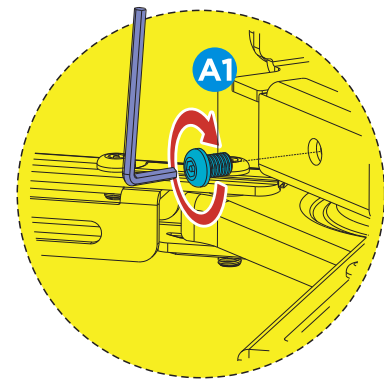
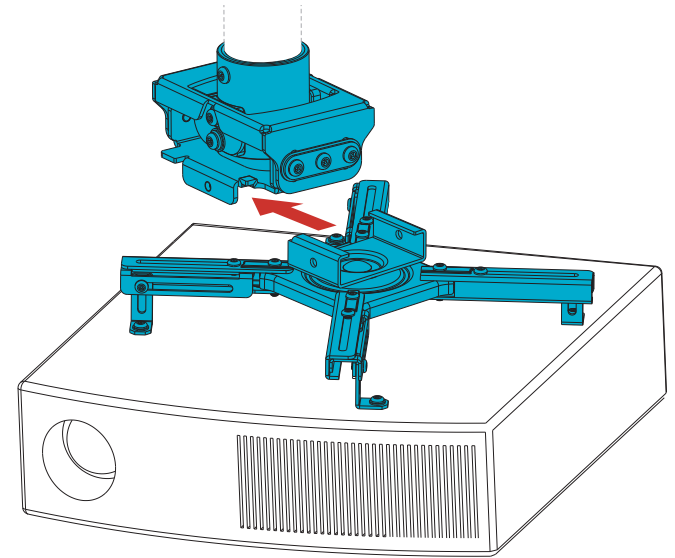

5A Adjustments – Pitch

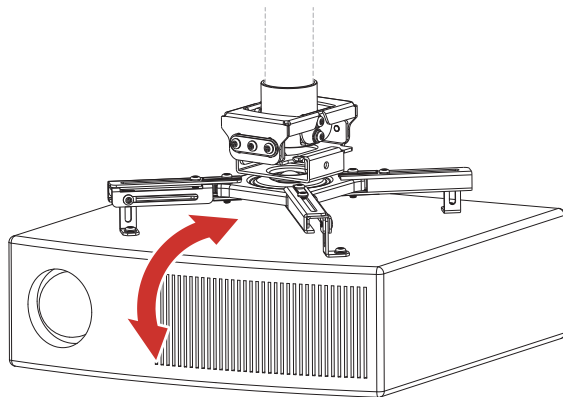
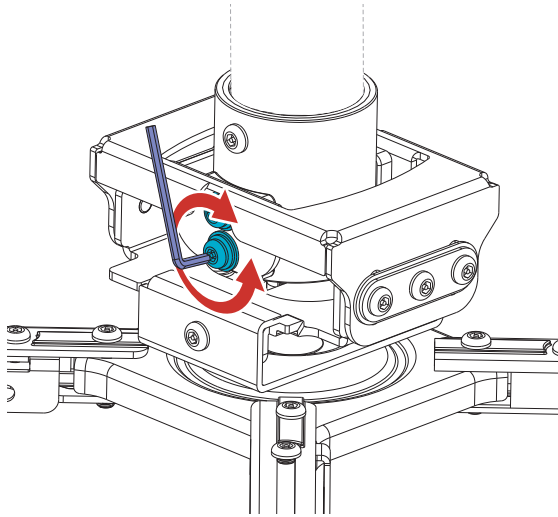

5B Adjustments – Roll

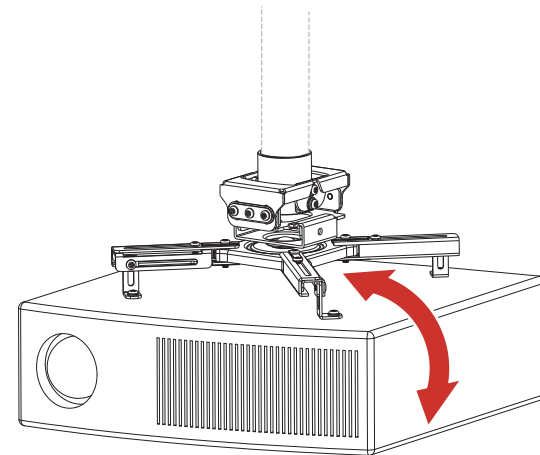
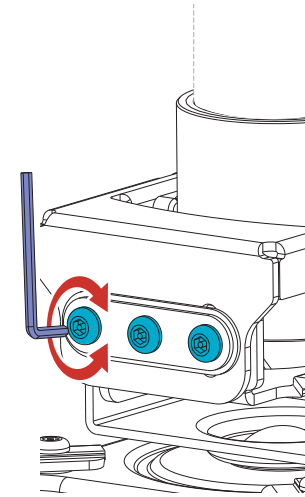

5C Adjustments – Swivel

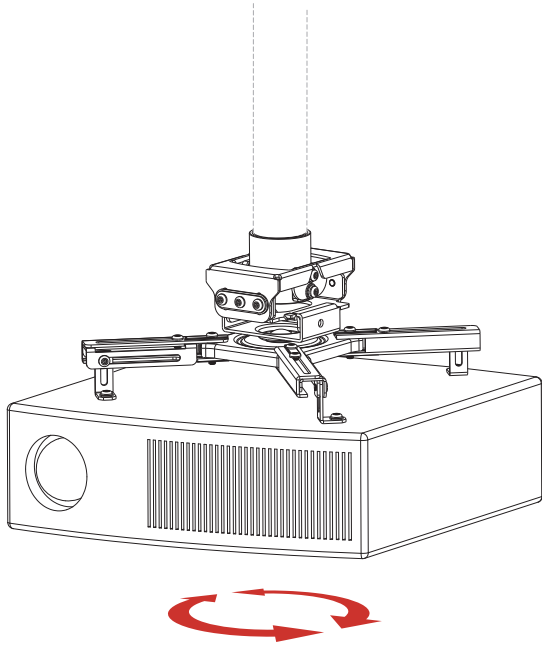

6A Maintenance - Detach the Projector Assembly from the Extension Column

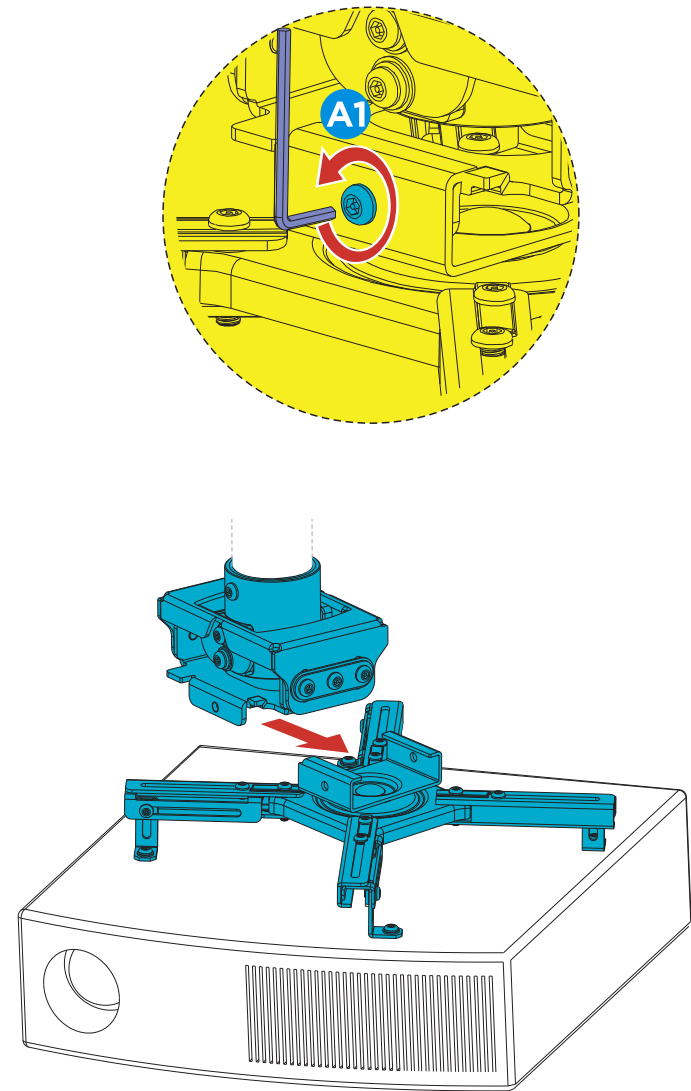

6B Remove the Projector Mounting Screws

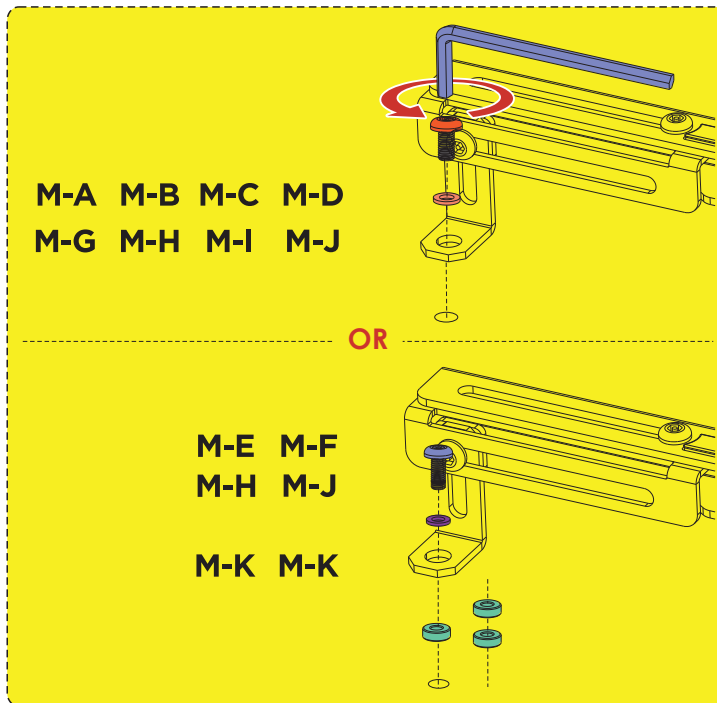

6C Detach the Projector Bracket from the Projector

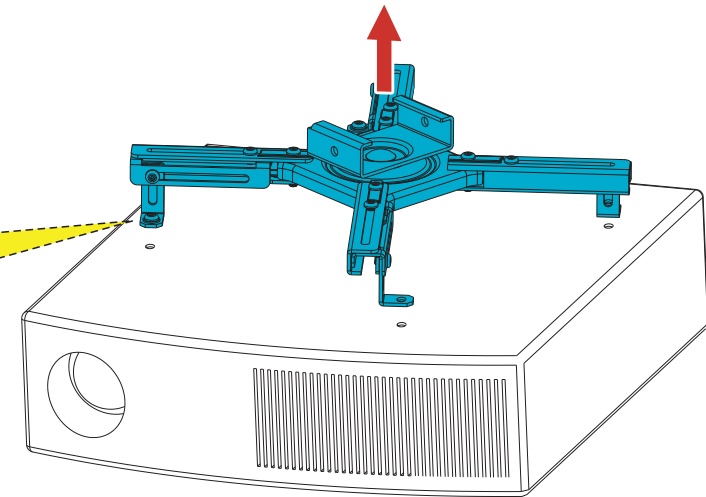

Maintenance

Please check that the projector assembly is secure and safe to use regularly. If you have questions about the instructions, please contact QualGear technical support at support@qualgear.com.