

BASIC SERIAL COMMAND SPECIFICATIONS

PLC-XU305
PLC-XU355

Ver.1.00

SANYO Electric Co., Ltd
DS Company
Projector Division

- CONTENTS -

1. Overview	4
2. Serial Interface Specifications	4
2.1. Transfer Specifications	4
2.2. Connection	4
3. Notes for Communication	5
4. Functional Execution Command Table.....	6
5. Status Read Command Table.....	8
6. Functional Execution Command	9
6.1. Format	9
6.2. Command Pipelining	9
6.3. Transfer Example	9
6.4. Operation Requirements	10
6.5. POWER ON Command	11
6.6. POWER OFF Command (Quick Power OFF)	11
6.7. POWER OFF Command.....	11
6.8. Computer 1 Command	11
6.9. Computer 2 Command	11
6.10. Video Command.....	12
6.11. Network Command	12
6.12. VOLUME + Command	12
6.13. VOLUME – Command	12
6.14. AUDIO MUTE ON Command	12
6.15. AUDIO MUTE OFF Command	12
6.16. VIDEO MUTE ON Command	13
6.17. VIDEO MUTE OFF Command.....	13
6.18. Screen Normal size Command	13
6.19. Screen Wide size Command	13
6.20. Image Standard Command	13
6.21. Image Real Command	13
6.22. Image Cinema Command	14
6.23. Image1 Command	14
6.24. Image2 Command	14
6.25. Image3 Command	14
6.26. Image4 Command	14
6.27. Image Blackboard (Green) Command	14
6.28. Image Dynamic Command	14
6.29. MENU ON Command	15
6.30. MENU OFF Command.....	15
6.31. DISPLAY CLEAR Command.....	15

6.32.	BRIGHTNESS + Command	15
6.33.	BRIGHTNESS – Command	15
6.34.	Computer 2 RGB Command	15
6.35.	IMAGE (Toggle) Command	16
6.36.	ON START Setting Command	16
6.37.	ON START Cancel Command	16
6.38.	Power Management Ready Command	16
6.39.	Power Management OFF Command	16
6.40.	Power Management Shut down Command	16
6.41.	D.ZOOM + Command	17
6.42.	D.ZOOM – Command	17
6.43.	S-Video Command	17
6.44.	Image Colorboard Command	17
6.45.	POINTER RIGHT Command	17
6.46.	POINTER LEFT Command	17
6.47.	POINTER UP Command	18
6.48.	POINTER DOWN Command	18
6.49.	ENTER Command	18
6.50.	FREEZE ON Command	18
6.51.	FREEZE OFF Command	18
6.52.	Computer 1 Analog RGB Command	18
6.53.	Computer 1 Scart Command	19
6.54.	Computer 1 Component Command	19
6.55.	PAGE UP Command	19
6.56.	PAGE DOWN Command	19
6.57.	Computer 2 DVI (PC Digital) Command	19
6.58.	Computer 2 DVI (AV HDCP) Command	19
6.59.	AUTO PC ADJ. Command	20
6.60.	PRESENTATION TIMER Command	20
6.61.	KEYSTONE ↑Command	20
6.62.	KEYSTONE ↓Command	20
7.	Status Read Command	21
7.1.	Format	21
7.2.	Transfer Example	21
7.3.	Status Read Command	22
7.4.	Input Mode Read Command	24
7.5.	Lamp Time Read Command	24
7.6.	Setting Read Command	24
7.7.	Temp Read Command	24
7.8.	Lamp Mode Read Command	25

1. Overview

- 1.1. These specifications define projector control commands for PLC-XU305/355.
- 1.2. The projector control commands are used to remotely control a projector through RS-232C from a computer.

2. Serial Interface Specifications

2.1. Transfer Specifications

Item	Specifications
Synchronous system	Asynchronous
Transmission Speed	9600 / 19200
Data Length	8 bit
Parity	N/A
Stop Bit	1
Flow Control	N/A

- 1) Transmission speed: initial setting value is 19200.
- 2) Transmission speed can be changed in service mode.

2.2. Connection

Dedicated serial cable must be used for connection to a computer and a projector.

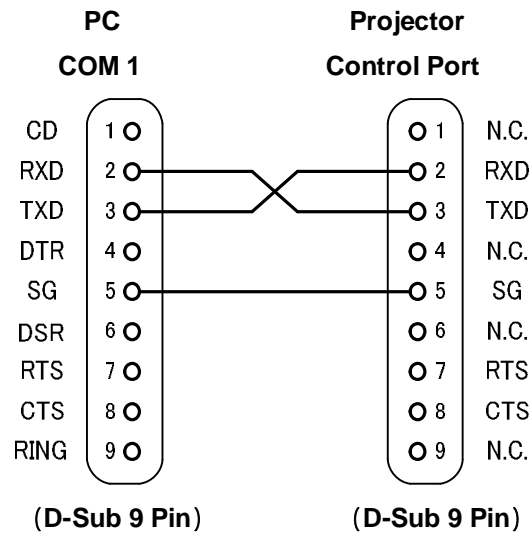

3. Notes for Communication

1. The projector control command is defined as one command/one line that starts with "C" and ends with carriage return (0x0D).
2. There are two types of Commands: Functional Execution Commands and Status Read Commands.

Example of Functional Execution Command: "C05" [CR]

Example of Status Read Command: "CR0" [CR]

3. When it takes more than one second to receive one command, it does not operate.
The information of buffer is cleared when it takes more than one second to receive carriage return (0x0D) after the projector receives the first data "C".
4. For Command pipelining, wait for the interval of 100ms after receiving a response.

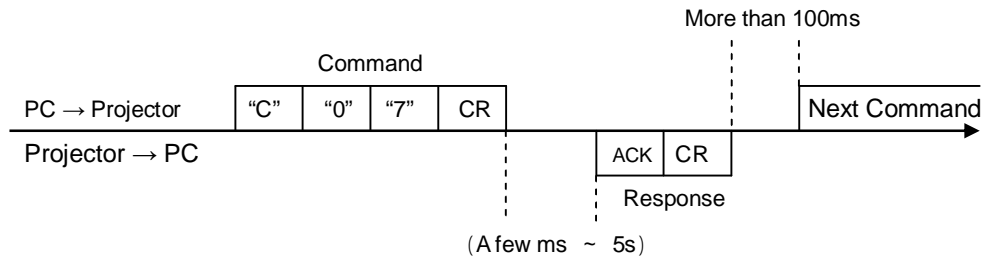

- 3.4.1. When a command is issued before receiving a response, the function is not executed properly.
- 3.4.2. Except for when there is no Response for more than 5 seconds.
5. It takes about 5 seconds for internal initialization after plugging in AC power. During this time, it cannot process commands. Do not issue any command.
6. The number of characters of response to Status Read Commands depends on commands.
Please see [7. Status Read Commands].
7. Characters for commands must be Capital (A - Z).

4. Functional Execution Command Table

Command	Item	Command	Item
C00	POWER ON	C20	BRIGHTNESS +
C01	POWER OFF (Quick Power OFF)	C21	BRIGHTNESS -
C02	POWER OFF	C22	-----
C03	-----	C23	-----
C04	-----	C24	-----
C05	Computer 1	C25	Computer 2 RGB
C06	Computer 2	C26	-----
C07	Video	C27	IMAGE (Toggle)
C08	Network	C28	ON START Enable
C09	VOLUME +	C29	ON START Disable
C0A	VOLUME -	C2A	Power Management Ready
C0B	AUDIO MUTE ON	C2B	Power Management OFF
C0C	AUDIO MUTE OFF	C2C	-----
C0D	VIDEO MUTE ON	C2D	-----
C0E	VIDEO MUTE OFF	C2E	Power Management Shut down
C0F	Screen Normal size (4:3)	C2F	-----
C10	Screen Wide size (16:9)	C30	D.ZOOM +
C11	Image Standard	C31	D.ZOOM -
C12	Image Real	C32	-----
C13	Image Cinema	C33	-----
C14	Image 1	C34	S-video
C15	Image 2	C35	-----
C16	Image 3	C36	-----
C17	Image 4	C37	-----
C18	Blackboard	C38	-----
C19	Dynamic	C39	Image Colorboard
C1A	-----	C3A	POINTER RIGHT
C1B	-----	C3B	POINTER LEFT
C1C	MENU ON	C3C	POINTER UP
C1D	MENU OFF	C3D	POINTER DOWN
C1E	DISPLAY CLEAR	C3E	-----
C1F	-----	C3F	ENTER

----- means no function.

Command	Item	Command	Item
C40	-----	C80	-----
C41	-----	C81	-----
C42	-----	C82	-----
C43	FREEZE ON	C83	-----
C44	FREEZE OFF	C84	-----
C45	-----	C85	-----
C46	-----	C86	-----
C47	-----	C87	-----
C48	-----	C88	-----
C49	-----	C89	Auto PC ADJ.
C4A	-----	C8A	PRESENTATION TIMER
C4B	-----	C8B	-----
C4C	-----	C8C	-----
C4D	-----	C8D	-----
C4E	-----	C8E	KEYSTONE ↑
C4F	-----	C8F	KEYSTONE ↓
C50	Computer 1 Analog RGB	C90	-----
C51	Computer 1 Scart	C91	-----
C52	-----	C92	-----
C53	-----	C93	-----
C54	Computer 1 Component	C94	-----
C55	-----	C95	-----
C56	-----	C96	-----
C57	-----	C97	-----
C58	-----	C98	-----
C59	Page UP	C99	-----
C5A	Page DOWN	C9A	-----
C5B	Computer 2 DVI (PC Digital)	C9B	-----
C5C	Computer 2 DVI (AV HDCP)	C9C	-----

----- means no function.

5. Status Read Command Table

Command	Item	Memo
CR0	Status Read	
CR1	Input Mode Read	
CR2	-----	
CR3	(Corresponding) Lamp Time Read	
CR4	Setting Read	
CR5	-----	
CR6	Temp Read	
CR7	Lamp Mode Read	

----- means no function.

6. Functional Execution Command

6.1. Format

6.1.1 PC issues a command in format as below.

“C” **COMMAND** [CR]

Command: two characters (See Basic Functional Execution Command Table)

A projector changes received data to decode and returns a result after being ready to receive next command.

[ACK][CR] : (0x06, 0x0D) When received Functional Execution Commands.

6.1.2 “?”[CR] : When the received data cannot be decoded.

6.2. Command Pipelining

When some functions need the command pipelining, the performance is the same as that of the remote control;

6.2.1. System: issues any command every 100 ms.

6.2.2. When receiving the appropriate command, the function is executed for 120 ms from the moment.

6.2.3. When receiving the same command continuously within 120 ms, the function is executed for another 120 ms from the moment.

6.2.4. When there is no incoming command after 120 ms, the execution of pipelining is stopped.

6.2.5. When the projector receives other incoming commands within 120ms, the execution of pipelining is stopped.

6.3. Transfer Example

Switch the projector to video mode with Basic Command.

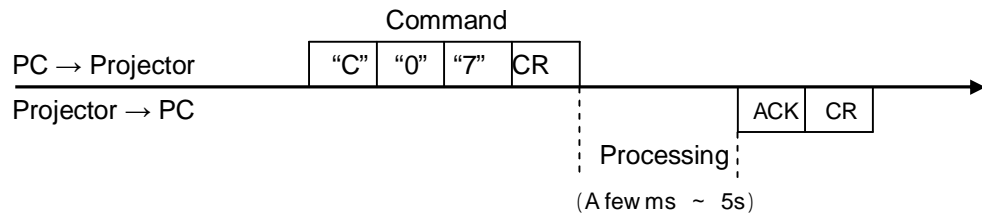

6.4. Operation Requirements

When the projector's status is any of below, Functional Execution Commands are limited.

Projector Status	Available Functional Execution Commands
Standby Mode	C00:POWER ON
Countdown in process	C00:POWER ON → Countdown is terminated C01:POWER OFF C02:POWER OFF → Countdown is terminated
Cooling Down in process	NONE (No Execution)
Cooling Down due to Abnormal Temperature	NONE (No Execution)
Abnormal Temperature Status	NONE (No Execution)
Abnormal Power Status	NONE (No Execution)
Power Save / Cooling Down in process	NONE (No Execution)
Power Save Status	C00:POWER ON C01:POWER OFF
Input search : On1/On2 setting	Although transmit Input source commands, Input search does not operate.

Note) When the status is as above, even if the projector receives other commands,

it returns **[ACK] [CR]**.

6.5. POWER ON Command

Command	"C00" [CR]	
Detail	Power ON When already Power is ON, nothing is done. When sending this command during processing Countdown, Countdown is terminated.	
Response	Acceptable	[ACK] [CR]
	Unacceptable	" ? "[CR]

6.6. POWER OFF Command (Quick Power OFF)

Command	"C01" [CR]	
Detail	Power OFF (Standby) When Power is OFF with ON/STAND-BY button of the projector and remote control, "Power OFF?" is displayed. However, as soon as this command is sent, Quick Power OFF is executed.	
Response	Acceptable	[ACK] [CR]
	Unacceptable	" ? "[CR]

6.7. POWER OFF Command

Command	"C02" [CR]	
Detail	Power OFF (Standby). The command operates the same Power OFF function as ON/STAND-BY button of the projector and remote control. Once this command is sent, "Power OFF?" is displayed. If this command is sent again while it is displayed, Power OFF is executed. When sending this command during Countdown, Countdown is terminated.	
Response	Acceptable	[ACK] [CR]
	Unacceptable	" ? "[CR]

6.8. Computer 1 Command

Command	"C05" [CR]	
Detail	Select Computer 1 Input Although Input search is set to On1 or On2, Input search is not executed with this command while projector returns "OK".	
Response	Acceptable	[ACK] [CR]
	Unacceptable	" ? "[CR]

6.9. Computer 2 Command

Command	"C06" [CR]	
Detail	Select Computer2 Input Although Input search is set to On1 or On2, Input search is not executed with this command while projector returns "OK".	
Response	Acceptable	[ACK] [CR]
	Unacceptable	" ? "[CR]

6.10. Video Command

Command	"C07" [CR]	
Detail	Select Video Input Although Input search is set to On1 or On2, Input search is not executed with this command while projector returns "OK".	
Response	Acceptable	[ACK] [CR]
	Unacceptable	" ? "[CR]

6.11. Network Command

Command	"C08" [CR]	
Detail	Select Network as input.	
Response	Acceptable	[ACK] [CR]
	Unacceptable	" ? "[CR]

6.12. VOLUME + Command

Command	"C09" [CR]	
Detail	Volume Up. This command operates the same way as "VOLUME+" button of the projector and remote control.	
Response	Acceptable	[ACK] [CR]
	Unacceptable	" ? "[CR]

6.13. VOLUME – Command

Command	"C0A" [CR]	
Detail	Volume Down This command operates the same way as "VOLUME-" button of the projector and remote control.	
Response	Acceptable	[ACK] [CR]
	Unacceptable	" ? "[CR]

6.14. AUDIO MUTE ON Command

Command	"C0B" [CR]	
Detail	Sound Mute ON. This command works the same way as "MUTE" button of the remote control for Mute ON, but does not work for Mute OFF.	
Response	Acceptable	[ACK] [CR]
	Unacceptable	" ? "[CR]

6.15. AUDIO MUTE OFF Command

Command	"C0C" [CR]	
Detail	Sound Mute OFF. This command works the same way as "MUTE" button of the remote control for Mute OFF, but does not work for Mute ON.	
Response	Acceptable	[ACK] [CR]
	Unacceptable	" ? "[CR]

6.16. VIDEO MUTE ON Command

Command	"C0D"[CR]	
Detail	Video Mute ON. This command works the same way as "NO SHOW" button of the remote control for No Show ON, but does not work for No Show OFF.	
Response	Acceptable	[ACK] [CR]
	Unacceptable	" ? "[CR]

6.17. VIDEO MUTE OFF Command

Command	"C0E" [CR]	
Detail	Video Mute OFF. This command works the same way as "NO SHOW" button of remote control for No Show OFF, but does not work for No Show ON.	
Response	Acceptable	[ACK] [CR]
	Unacceptable	" ? "[CR]

6.18. Screen Normal size Command

Command	"C0F" [CR]	
Detail	Set screen mode to Normal. This command is invalid while D.Zoom is in operation.	
Response	Acceptable	[ACK] [CR]
	Unacceptable	" ? "[CR]

6.19. Screen Wide size Command

Command	"C10" [CR]	
Detail	Set screen mode to Wide. This command is invalid while D.Zoom is in operation.	
Response	Acceptable	[ACK] [CR]
	Unacceptable	" ? "[CR]

6.20. Image Standard Command

Command	"C11" [CR]	
Detail	Set image to Standard mode.	
Response	Acceptable	[ACK] [CR]
	Unacceptable	" ? "[CR]

6.21. Image Real Command

Command	"C12" [CR]	
Detail	Set image to Real mode.	
Response	Acceptable	[ACK] [CR]
	Unacceptable	" ? "[CR]

6.22. Image Cinema Command

Command	"C13" [CR]	
Detail	Set image to Cinema mode.	
Response	Acceptable	[ACK] [CR]
	Unacceptable	" ? "[CR]

6.23. Image1 Command

Command	"C14" [CR]	
Detail	Set image to Image1 mode.	
Response	Acceptable	[ACK] [CR]
	Unacceptable	" ? "[CR]

6.24. Image2 Command

Command	"C15" [CR]	
Detail	Set image to Image2 mode.	
Response	Acceptable	[ACK] [CR]
	Unacceptable	" ? "[CR]

6.25. Image3 Command

Command	"C16" [CR]	
Detail	Set image to Image3 mode.	
Response	Acceptable	[ACK] [CR]
	Unacceptable	" ? "[CR]

6.26. Image4 Command

Command	"C17" [CR]	
Detail	Set image to Image4 mode.	
Response	Acceptable	[ACK] [CR]
	Unacceptable	" ? "[CR]

6.27. Image Blackboard (Green) Command

Command	"C18" [CR]	
Detail	Set image to Blackboard (Green) mode.	
Response	Acceptable	[ACK] [CR]
	Unacceptable	" ? "[CR]

6.28. Image Dynamic Command

Command	"C19" [CR]	
Detail	Set image to Dynamic mode.	
Response	Acceptable	[ACK] [CR]
	Unacceptable	" ? "[CR]

6.29. MENU ON Command

Command	"C1C" [CR]	
Detail	Display On-Screen Display Menu.	
Response	Acceptable	[ACK] [CR]
	Unacceptable	" ? "[CR]

6.30. MENU OFF Command

Command	"C1D" [CR]	
Detail	Hide On-Screen Display Menu.	
Response	Acceptable	[ACK] [CR]
	Unacceptable	" ? "[CR]

6.31. DISPLAY CLEAR Command

Command	"C1E" [CR]	
Detail	Hide On-Screen Display. Hide On-Screen Display unconditionally.	
Response	Acceptable	[ACK] [CR]
	Unacceptable	" ? "[CR]

6.32. BRIGHTNESS + Command

Command	"C20" [CR]	
Detail	Brightness of User Control +1.	
Response	Acceptable	[ACK] [CR]
	Unacceptable	" ? "[CR]

6.33. BRIGHTNESS – Command

Command	"C21" [CR]	
Detail	Brightness of User Control –1.	
Response	Acceptable	[ACK] [CR]
	Unacceptable	" ? "[CR]

6.34. Computer 2 RGB Command

Command	"C25"[CR]	
Detail	Select RGB input in Computer2. Although projector returns "OK", this command is not executed while Input search is On1/On2.	
Response	Acceptable	[ACK] [CR]
	Unacceptable	" ? "[CR]

6.35. IMAGE (Toggle) Command

Command	"C27"[CR]	
Detail	Switch Image Setting status. This command works the same way as "IMAGE" button of the remote control.	
Response	Acceptable	[ACK] [CR]
	Unacceptable	" ? "[CR]

6.36. ON START Setting Command

Command	"C28" [CR]	
Detail	Enable Power ON Start. This status is stored in EEPROM and retained regardless of Power OFF/ON.	
Response	Acceptable	[ACK] [CR]
	Unacceptable	" ? "[CR]

6.37. ON START Cancel Command

Command	"C29" [CR]	
Detail	Disable Power ON Start. This status is stored in EEPROM and retained regardless of Power OFF/ON.	
Response	Acceptable	[ACK] [CR]
	Unacceptable	" ? "[CR]

6.38. Power Management Ready Command

Command	"C2A" [CR]	
Detail	Set Power Management to Ready mode. This status is stored in EEPROM and retained regardless of Power ON/OFF.	
Response	Acceptable	[ACK] [CR]
	Unacceptable	" ? "[CR]

6.39. Power Management OFF Command

Command	"C2B" [CR]	
Detail	Set Power Management to OFF mode. This status is stored in EEPROM and retained regardless of Power ON/OFF.	
Response	Acceptable	[ACK] [CR]
	Unacceptable	" ? "[CR]

6.40. Power Management Shut down Command

Command	"C2E" [CR]	
Detail	Set Power Management to Shut down mode. This status is stored in EEPROM and retained regardless of Power OFF/ON.	
Response	Acceptable	[ACK] [CR]
	Unacceptable	" ? "[CR]

6.41. D.ZOOM + Command

Command	"C30" [CR]	
Detail	Enter Digital Zoom mode and expand image size. This command works the same way as "D.ZOOM ▲" button of the remote control.	
Response	Acceptable	[ACK] [CR]
	Unacceptable	" ? "[CR]

6.42. D.ZOOM – Command

Command	"C31" [CR]	
Detail	Enter Digital Zoom mode and reduce image size. This command works the same as "D.ZOOM ▼" button of the remote control.	
Response	Acceptable	[ACK] [CR]
	Unacceptable	" ? "[CR]

6.43. S-Video Command

Command	"C34" [CR]	
Detail	Select S-Video input. Although Input search is set to On1 or On2, Input search is not executed with this command while projector returns "OK".	
Response	Acceptable	[ACK] [CR]
	Unacceptable	" ? "[CR]

6.44. Image Colorboard Command

Command	"C39" [CR]	
Detail	Set image to Colorboard mode.	
Response	Acceptable	[ACK] [CR]
	Unacceptable	" ? "[CR]

6.45. POINTER RIGHT Command

Command	"C3A" [CR]	
Detail	Move the Pointer of On-Screen Display Menu to the right. This command works differently from the pointer ">" of the projector and remote control, and has no function of Volume +.	
Response	Acceptable	[ACK] [CR]
	Unacceptable	" ? "[CR]

6.46. POINTER LEFT Command

Command	"C3B" [CR]	
Detail	Move the Pointer of On-Screen Display Menu to the left. This command works differently from the pointer "<" of the projector and remote control, and has no function of Volume +.	
Response	Acceptable	[ACK] [CR]
	Unacceptable	" ? "[CR]

6.47. POINTER UP Command

Command	"C3C" [CR]	
Detail	Move up the Pointer of On-Screen Display Menu. This command works the same way as the pointer "▲" of the projector.	
Response	Acceptable	[ACK] [CR]
	Unacceptable	" ? "[CR]

6.48. POINTER DOWN Command

Command	"C3D" [CR]	
Detail	Move down the Pointer of On-Screen Display Menu. This command works the same way as the pointer "▼" of the projector.	
Response	Acceptable	[ACK] [CR]
	Unacceptable	" ? "[CR]

6.49. ENTER Command

Command	"C3F" [CR]	
Detail	This command works the same way as "SELECT" button of the projector and remote control.	
Response	Acceptable	[ACK] [CR]
	Unacceptable	" ? "[CR]

6.50. FREEZE ON Command

Command	"C43" [CR]	
Detail	Freeze on-screen image. This command works the same way as "FREEZE" button of the remote control for Freeze ON, but does not work for Freeze OFF.	
Response	Acceptable	[ACK] [CR]
	Unacceptable	" ? "[CR]

6.51. FREEZE OFF Command

Command	"C44" [CR]	
Detail	Cancel Freeze mode. This command works the same way as "FREEZE" button of the remote control for Freeze OFF, but does not work for Freeze ON.	
Response	Acceptable	[ACK] [CR]
	Unacceptable	" ? "[CR]

6.52. Computer 1 Analog RGB Command

Command	"C50" [CR]	
Detail	Select Analog RGB input in Computer 1. Although Input search is set to On1 or On2, Input search is not executed with this command while projector returns "OK".	
Response	Acceptable	[ACK] [CR]
	Unacceptable	" ? "[CR]

6.53. Computer 1 Scart Command

Command	"C51" [CR]	
Detail	Select Scart input in Computer 1 Although Input search is set to On1 or On2, Input search is not executed with this command while projector returns "OK".	
Response	Acceptable	[ACK] [CR]
	Unacceptable	" ? "[CR]

6.54. Computer 1 Component Command

Command	"C54" [CR]	
Detail	Select Component input in Computer 1. Although Input search is set to On1 or On2, Input search is not executed with this command while projector returns "OK".	
Response	Acceptable	[ACK] [CR]
	Unacceptable	" ? "[CR]

6.55. PAGE UP Command

Command	"C59" [CR]	
Detail	Send the signal "Page Up" to PC when PC is connected to projector through USB.	
Response	Acceptable	[ACK] [CR]
	Unacceptable	" ? "[CR]

6.56. PAGE DOWN Command

Command	"C5A" [CR]	
Detail	Send the signal "Page Down" to PC when PC is connected to projector through USB.	
Response	Acceptable	[ACK] [CR]
	Unacceptable	" ? "[CR]

6.57. Computer 2 DVI (PC Digital) Command

Command	"C5B" [CR]	
Detail	Select DVI input (PC Digital) in Computer 2 Although Input search is set to On1 or On2, Input search is not executed with this command while projector returns "OK".	
Response	Acceptable	[ACK] [CR]
	Unacceptable	" ? "[CR]

6.58. Computer 2 DVI (AV HDCP) Command

Command	C5C" [CR]	
Detail	Select DVI input (AV HDCP) in Computer 2 Although Input search is set to On1 or On2, Input search is not executed with this command while projector returns "OK".	
Response	Acceptable	[ACK] [CR]
	Unacceptable	" ? "[CR]

6.59. AUTO PC ADJ. Command

Command	"C89" [CR]	
Detail	Execute Auto PC Adj. function. This command operates the same as "AUTO PC ADJ." of main menu. Projector suspends Auto PC Adj. operation when receiving this command another time.	
Response	Acceptable	[ACK] [CR]
	Unacceptable	" ? "[CR]

6.60. PRESENTATION TIMER Command

Command	"C8A" [CR]	
Detail	Execute Presentation Timer. This command works the same way as "P-TIMER" button of the remote control.	
Response	Acceptable	[ACK] [CR]
	Unacceptable	" ? "[CR]

6.61. KEYSTONE ↑Command

Command	"C8E" [CR]	
Detail	Correct keystone distortion by reducing upper part of image.	
Response	Acceptable	[ACK] [CR]
	Unacceptable	" ? "[CR]

6.62. KEYSTONE ↓Command

Command	"C8F" [CR]	
Detail	Correct keystone distortion by reducing down part of image.	
Response	Acceptable	[ACK] [CR]
	Unacceptable	" ? "[CR]

7. Status Read Command

7.1.Format

7.1.1. PC issues commands in format as below;

"CR" Command [CR]

Command : 1 character (See Basic Status Read Command Table)

7.1.2. When a projector receives the appropriate command, it returns a character line as the required data.

Required Data [CR]

Required Data : A character line (See Basic Status Read Command Table)

7.1.3. When the received data cannot be decoded, the projector returns "?" [CR].

7.2.Transfer Example

Get input mode for projector with basic commands

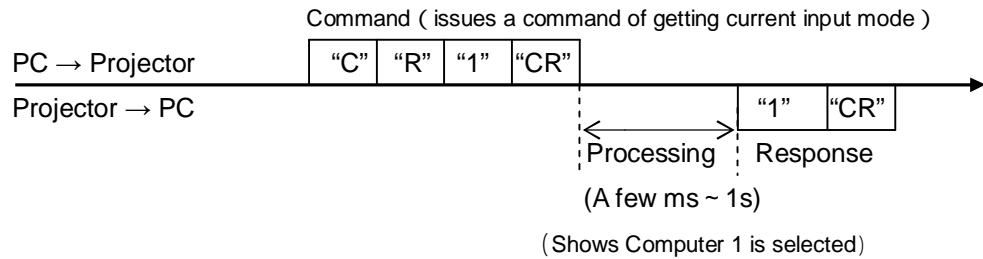

7.3. Status Read Command

Command	"CR0" [CR]	
Detail	Get the projector's operating status	
Response	Acceptable	"%1" [CR]
	%1	"00" = Power ON "80" = Standby "40" = Countdown in process "20" = Cooling Down in process "10" = Power Failure "28" = Cooling Down in process due to Temperature Anomaly "88" = Coming back after Temperature Anomaly "24" = Power Save/Cooling Down in process "04" = Power Save "21" = Cooling Down is in process after Power off due to lamp failure "81" = Standby after Cooling Down due to lamp failure
	Unacceptable	"?" [CR]

[Details of Response]

"00" [CR]

Status : Power ON

Normal image is on the screen.

"80" [CR]

Status: Standby

When the status is Standby, Status Read Commands are always acceptable, but Functional Execution Commands are not acceptable except POWER ON Command.

"40" [CR]

Status: Countdown in process

When "Display" in Setting Menu is ON and POWER ON is executed, it starts Countdown.

When "Display" in Setting Menu is OFF, processing Countdown is not executed and the status quickly moves to Power ON.

"20" [CR]

Status: Cooling Down in process

When the status is Power ON, and POWER OFF Command ("C01"[CR]) is executed, it moves to Cooling Down status.

This status automatically moves to Standby after lamp turns off and the fan spin finishes after about 90 seconds. The fan spin time depends on a model.

This function is used to cool down the lamps and other optical parts and is quite important for projector's reliability.

During this time, Functional Execution Commands are invalid.

"10" [CR]

Status: Power Failure

When the power supply voltage inside the projector reaches abnormal status, the projector is automatically turned off. The projector returns "10"[CR], which shows it

moves to Power OFF status due to power failure. Fan also stops unlike Cooling Down status.

“28” [CR]

Status: Cooling Down in process due to Temperature Anomaly

When the inside temperature is out of the operating temperature, it automatically starts Cooling Down. Response for this status is “28”[CR].

Even if the temperature decreases during this process, Cooling Down is executed.

“88”[CR]

Status: Coming back after temperature anomaly

When the status moves to Standby after Cooling Down due to temperature anomaly, it returns “88” [CR].

This shows that the status turns to Standby because of abnormal temperature.

This status maintains until next operation is done. When Power On is executed, the information of temperature anomaly is canceled and normal operation is executed.

“24”[CR]

Status: Processing Power Save / Cooling Down

Power management function in Setting menu works and the status goes to Power Save / Cooling Down.

During this time, Functional Execution Commands are invalid (not executed).

This status moves to Power Save at set hours after the operation of Cooling Down.

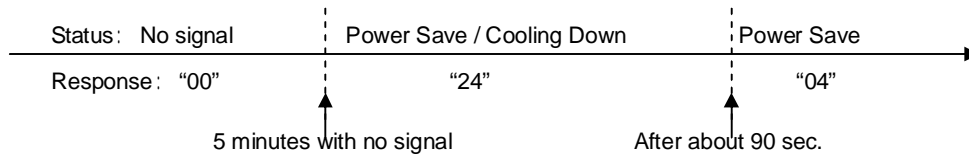

“04”[CR]

Status: Power Save

This shows that it moves to Power Save status by Power management function in Setting menu.

“21” [CR]

Status: Cooling Down in process after turned off due to lamp failure

When a projector is turned off because of lamp failure, it automatically starts Cooling Down operation, in which the projector returns “21” [CR].

“81”[CR]

Status: Standby after Cooling Down due to lamp failure

This value is returned when Cooling Down operation due to lamp failure has been completed and the status has been moved to Standby. The status is kept until the next operation starts.

7.4. Input Mode Read Command

Command	"CR1" [CR]	
Detail	Get the selected Input No.	
Response	Acceptable	"%1" [CR]
	%1	"1" = Computer 1 is selected "2" = Computer 2 is selected "3" = Video is selected "4" = Wired is selected "5" = Wireless/Viewer is selected
	Unacceptable	"?" [CR]

7.5. Lamp Time Read Command

Command	"CR3" [CR]	
Detail	Get the total lamp running hours (Not actual lamp used hour, but Eco mode corresponding value).	
Response	Acceptable	"%1" [CR]
	%1	Shows the time period with 5 digits numbers. Example: "00410"[CR] ... shows 410 hours
	Unacceptable	"?" [CR]

7.6. Setting Read Command

Command	"CR4" [CR]	
Detail	Get screen setting status such as Ceiling / Rear.	
Response	Acceptable	"%1" [CR]
	%1	"11"[CR] = Normal Screen Setting "10"[CR] = Picture is top/bottom reversed. (Status: Rear & Ceiling ON) "01"[CR] = Picture is left/right reversed. (Status: Rear ON) "00"[CR] = Picture is top/bottom and left/right reversed. (Status: Ceiling ON)
	Unacceptable	"?" [CR]

7.7. Temp Read Command

Command	"CR6" [CR]	
Detail	Get the temperature data inside the projector. With some temperature sensors installed in the projector, it is possible to get all the temperature at once.	
Response	Acceptable	"%1_%2_%3" [CR]
	%1 %2 %3	%1 = Temperature of sensor 1 %2 = Temperature of sensor 2 %3 = Temperature of sensor 3 Temperature data is shown as "00.0". When the temperature goes down to -, the first character becomes "-" instead of a space, like "-05.5" [CR]. When no temperature data can be returned due to hardware problems, the first character becomes "E" like"E00.0" [CR]. When several temperature sensors are equipped, Responses are returned continuously. "_31.5 _ _35.2 _ _33.4"[CR] The first data is sensor 1, then one space, and the data of sensor 2 follows.
	Unacceptable	" ? "[CR]

7.8.Lamp Mode Read Command

Command	"CR7" [CR]	
Detail	Get lamp mode status. For 1 lamp projector, get if it is lighting or not.	
Response	Acceptable	"%1" [CR]
	%1	"00" [CR]=Light is out. "01" [CR]=Light is on.
	Unacceptable	" ? "[CR]