

# ACS-2048



## User's Guide

- Manual #: 26-0603000-00
- Revision: 02



---

# ACS-2048 • User's Guide

## Copyright

© Barco. October 15, 2008

All rights reserved. No part of this document may be copied, reproduced or translated. It shall not otherwise be recorded, transmitted or stored in a retrieval system without the prior written consent of Barco.

## Notice

Barco provides this manual "as is" without warranty of any kind, either expressed or implied, including but not limited to the implied warranties or merchantability and fitness for a particular purpose. Barco may make improvements and/or changes to the product(s) and/or the program(s) described in this publication at any time without notice.

This publication could contain technical inaccuracies or typographical errors. Changes are periodically made to the information in this publication; these changes are incorporated in new editions of this publication.

## Federal Communications Commission (FCC) Statement

This equipment has been tested and found to comply with the limits for a class A digital device, pursuant to Part 15 of the FCC rules. These limits are designed to provide reasonable protection against harmful interference when the equipment is operated in a commercial environment. This equipment generates, uses, and can radiate radio frequency energy and, if not installed and used in accordance with the instruction manual, may cause harmful interference to radio communications. Operation of this equipment in a residential area may cause harmful interference, in which case the user will be responsible for correcting any interference.

## Guarantee and Compensation

Barco provides a guarantee relating to perfect manufacturing as part of the legally stipulated terms of guarantee. On receipt, the purchaser must immediately inspect all delivered goods for damage incurred during transport, as well as for material and manufacturing faults Barco must be informed immediately in writing of any complaints.

The period of guarantee begins on the date of transfer of risks, in the case of special systems and software on the date of commissioning, at latest 30 days after the transfer of risks. In the event of justified notice of compliant, Barco can repair the fault or provide a replacement at its own discretion within an appropriate period. If this measure proves to be impossible or unsuccessful, the purchaser can demand a reduction in the purchase price or cancellation of the contract. All other claims, in particular those relating to compensation for direct or indirect damage, and also damage attributed to the operation of software as well as to other services provided by Barco, being a component of the system or independent service, will be deemed invalid provided the damage is not proven to be attributed to the absence of properties guaranteed in writing or due to the intent or gross negligence or part of Barco.

If the purchaser or a third party carries out modifications or repairs on goods delivered by Barco, or if the goods are handled incorrectly, in particular if the systems are commissioned operated incorrectly or if, after the transfer of risks, the goods are subject to influences not

agreed upon in the contract, all guarantee claims of the purchaser will be rendered invalid. Not included in the guarantee coverage are system failures which are attributed to programs or special electronic circuitry provided by the purchaser, e.g. interfaces. Normal wear as well as normal maintenance are not subject to the guarantee provided by Barco either.

The environmental conditions as well as the servicing and maintenance regulations specified in this manual must be complied with by the customer.

## Trademarks

Brand and product names mentioned in this manual may be trademarks, registered trademarks or copyrights of their respective holders. All brand and product names mentioned in this manual serve as comments or examples and are not to be understood as advertising for the products or their manufactures.

---

## Company Address



**Barco Media and Entertainment**  
11101 Trade Center Drive  
Rancho Cordova, California 95670  
USA

- Phone: (916) 859-2500
- Fax: (916) 859-2515
- Website: [www.barco.com](http://www.barco.com)

**Barco N.V.**  
Noordlaan 5  
8520 Kuurne  
BELGIUM

- Phone: +32 56.36.82.11
- Fax: +32 56.35.16.51
- Website: [www.barco.com](http://www.barco.com)

### Digital Cinema Technical Support

- Tech Line: (888) 469-8036 — 24 hours per day, 7 days per week

---

## Operators Safety Summary

The general safety information in this summary is for operating personnel.

### Do Not Remove Covers or Panels

There are no user-serviceable parts within the unit. Removal of the top cover will expose dangerous voltages. To avoid personal injury, do not remove the top cover. Do not operate the unit without the cover installed.

### Power Source

This product is intended to operate from a power source that will not apply more than 230 volts rms between the supply conductors or between both supply conductor and ground. A protective ground connection by way of grounding conductor in the power cord is essential for safe operation.

### Grounding the Product

This product is grounded through the grounding conductor of the power cord. To avoid electrical shock, plug the power cord into a properly wired receptacle before connecting to the product input or output terminals. A protective-ground connection by way of the grounding conductor in the power cord is essential for safe operation.

### Use the Proper Power Cord

Use only the power cord and connector specified for your product. Use only a power cord that is in good condition. Refer cord and connector changes to qualified service personnel.

### Use the Proper Fuse

To avoid fire hazard, use only the fuse having identical type, voltage rating, and current rating characteristics. Refer fuse replacement to qualified service personnel.

### Do Not Operate in Explosive Atmospheres

To avoid explosion, do not operate this product in an explosive atmosphere.

---

## Terms In This Manual and Equipment Marking



### WARNING

Highlights an operating procedure, practice, condition, statement, etc., which, if not strictly observed, could result in injury to or death of personnel.

### Note

Highlights an essential operating procedure, condition or statement.
--



### CAUTION

The exclamation point within an equilateral triangle is intended to alert the user to the presence of important operating and maintenance (servicing) instructions in the literature accompanying the appliance.



### AVERTISSEMENT!

Le point d'exclamation dans un triangle équilatéral signale à alerter l'utilisateur qu'il y a des instructions d'opération et d'entretien très importantes dans la littérature qui accompagne l'appareil.



### VORSICHT

Ein Ausrufungszeichen innerhalb eines gleichwinkligen Dreiecks dient dazu, den Benutzer auf wichtige Bedienungs- und Wartungsanweisungen in der dem Great beiliegenden Literatur aufmerksam zu machen.

---

## Change History

The table below lists the changes to the ACS-2048 User's Guide.

**Table 0-1.** Change History

Rev	Date	ECP #	Description	Approved By
01	9/6/07	549078	ACS-2048 User's Guide	R. Pellicano
02	10/15/08	562625	Updates for code version 1.02	R. Pellicano



# Table of Contents

- Chapter 1 Introduction ..... 11**
  - In This Chapter ..... 11
  - Chapter Structure ..... 11
  - How to Use This Guide ..... 12
    - Navigating ..... 12
    - Table of Contents and Index ..... 12
  - Conventions ..... 12
  - About the ACS-2048 ..... 13
    - Overview ..... 13
    - Features ..... 13
    - What's New in Firmware Version 1.02 ..... 14
    - A Word About HDCP ..... 15
  - Connectivity Diagram ..... 16
  - Application Questions ..... 16
  
- Chapter 2 Hardware Orientation ..... 17**
  - In This Chapter ..... 17
  - ACS-2048 Front Panel ..... 18
    - Display Section ..... 20
    - Inputs Section ..... 21
  - ACS-2048 Rear Panel ..... 23
  
- Chapter 3 Installation ..... 25**
  - In This Chapter ..... 25
  - Safety Precautions ..... 26
  - Unpacking and Inspection ..... 26
  - Site Preparation ..... 26
  - Cable and Adapter Information ..... 26
  - Rack-Mount Installation ..... 27
  - Power Installation ..... 27
    - Power Cord/Line Voltage Selection ..... 28
  - Signal Installation ..... 29
  - Format Connection Table ..... 30
  
- Chapter 4 Operation ..... 31**
  - In This Chapter ..... 31
  - Control Overview ..... 32
  - Power-Up Initialization ..... 32
  - Quick Setup and Operations ..... 33
  - Menu Tree ..... 35

## Table of Contents

Using the Menu System . . . . .	36
Quick Function Reference . . . . .	38
Using the Main Menu . . . . .	41
In Auto Acquire . . . . .	42
Input Menu . . . . .	43
Input Format . . . . .	44
Type . . . . .	44
Colorspace . . . . .	45
Image Adjust . . . . .	46
Contrast . . . . .	47
Brightness . . . . .	47
Color Balance . . . . .	47
RGB Color Balance Menu . . . . .	47
Hue/Saturation Color Balance Menu . . . . .	48
Timing Adjust . . . . .	48
Processing . . . . .	50
Reset Config . . . . .	50
Save Input Config . . . . .	51
Delete Config . . . . .	52
Recall Config . . . . .	52
Output Menu . . . . .	53
Output Format . . . . .	53
Output Mode . . . . .	53
Gamma . . . . .	54
Test Pattern . . . . .	54
Output Adjust . . . . .	55
Save Output Config . . . . .	56
System Menu . . . . .	57
Trans Time . . . . .	57
VFD Brightness . . . . .	58
Ethernet . . . . .	58
EDID DVI Input Format . . . . .	60
DVI Cable Equalization . . . . .	62
Temperature . . . . .	62
User Preference . . . . .	63
File Association . . . . .	64
Diagnostics . . . . .	65
Save System Config . . . . .	65
Status Menu . . . . .	67
Software Version . . . . .	68
Factory Reset . . . . .	68
Using Inputs . . . . .	69
Understanding Backlighting . . . . .	69
Input Selection Rules . . . . .	69
Understanding Auto Acquire . . . . .	70
Using Test Patterns . . . . .	71
Front Panel Lockout . . . . .	72

## Chapter 5

## Upgrading Software . . . . . 73

In This Chapter . . . . .	73
Software Upgrade Overview . . . . .	74



Hardware Requirements . . . . .	74
Software Requirements . . . . .	74
Downloading Software . . . . .	75
Via FTP Site . . . . .	75
Via Web Site . . . . .	75
Ethernet Upgrade Method . . . . .	76
Troubleshooting Ethernet Communication . . . . .	79

**Appendix A Specifications . . . . . 81**

In This Appendix . . . . .	81
Input Specifications . . . . .	82
Output Specifications . . . . .	83
Physical and Electrical Specifications . . . . .	84
Communications Specifications . . . . .	85
Agency Specifications . . . . .	85
Pinouts . . . . .	86
Analog 15-pin D Connector . . . . .	86
DVI-I Connector Pinouts . . . . .	87
Ethernet Connector . . . . .	88
Mini-DIN Connector . . . . .	88
Input Format Table . . . . .	89

**Appendix B Remote Control Protocol . . . . . 93**

In This Appendix . . . . .	93
Communicating with ACS-2048 . . . . .	93
Command Protocol . . . . .	94
Command Responses . . . . .	94
Query Options . . . . .	94
IBRT . . . . .	94
Error Codes . . . . .	96
Error Codes: General Failures . . . . .	96
Error Codes: No Error . . . . .	96
ACS-2048 Command List . . . . .	97
Remote Commands . . . . .	98
AUTOACQ . . . . .	98
AUTOSAVE . . . . .	98
BLKVID . . . . .	98
CONTEXT . . . . .	99
DHCP . . . . .	99
EMAC . . . . .	99
GATEWAY . . . . .	99
ICDEL . . . . .	99
ICLIST . . . . .	100
ICREC . . . . .	100
ICSAV . . . . .	100
IHCROP . . . . .	101
IHPAN . . . . .	101
IMAP . . . . .	101
IP . . . . .	101

## Table of Contents

ISEL	102
ISTAT	102
IVCROP	102
IVPAN	102
LOCKOUT	102
OCSAV	103
OGM	103
OMODE	103
ORBM	103
ORES	104
OSTAT	104
OTPM	104
OTPT	104
RESET	105
SAVE	105
SELMODE	105
SUBNET	106
TEMP	106
TRNTIME	106
VER	106
VFDBRT	106

## Appendix C Contact Information .....107

In This Appendix	107
Warranty	107
Return Material Authorization (RMA)	107
Contact Information	108

## Index .....109

# 1. Introduction

---

## In This Chapter

This chapter is designed to introduce you to the ACS-2048 User's Guide. Areas to be covered are:

- [Chapter Structure](#)
- [How to Use This Guide](#)
- [Conventions](#)
- [About the ACS-2048](#)
- [Connectivity Diagram](#)
- [Application Questions](#)

---

## Chapter Structure

The following chapters provide instructions for all aspects of ACS-2048 operations:

- Chapter 1, "[Introduction](#)" provides a system overview, a list of features, and a system connectivity diagram.
- Chapter 2, "[Hardware Orientation](#)" on page 17 provides detailed diagrams of the system's front and rear panels.
- Chapter 3, "[Installation](#)" on page 25 provides comprehensive system installation instructions.
- Chapter 4, "[Operation](#)" on page 31 provides menu trees, plus comprehensive system operating instructions.
- Chapter 5, "[Upgrading Software](#)" on page 73 outlines procedures for upgrading system software components.
- Appendix A, "[Specifications](#)" on page 81 lists the ACS-2048's specifications.
- Appendix B, "[Remote Control Protocol](#)" on page 93 provides information regarding remote control protocol.
- Appendix C, "[Contact Information](#)" on page 107 lists important Barco contact, RMA, warranty and technical support details.

# 1. Introduction

## How to Use This Guide

---

## How to Use This Guide

This section provides important tips for streamlining your use of this User's Guide in its electronic "PDF" form.

### Navigating

Use Acrobat Reader's "bookmarks" to navigate to the desired location. All chapter files have the same bookmark structure for instant navigation to any section. Please note:



- Extensive hyperlinks are provided within the chapters.
- Use Acrobat's "**Go to Previous View**" and "**Return to Next View**" buttons to trace your complete navigational path.
- Use the "**Previous Page**" and "**Next Page**" buttons to go to the previous or next page within a file.
- Use Acrobat's extensive search capabilities, such as the "**Find**" tool and "**Search Index**" tool to perform comprehensive searches as required.

### Table of Contents and Index

Use the **Table of Contents** bookmarks to navigate a desired topic. Click any item to instantly jump to that section of the guide. You can also use the **Index** to jump to specific topics within a chapter. Each page number in the **Index** is a hyperlink.\

---

## Conventions

The following conventions are used throughout this guide:

- The symbol ■ denotes an operations procedure.
- The symbol ▲ denotes an example.
- Entries written in bold-face capital letters denote physical buttons or chassis connectors.
- The term "**select**" is used as an abbreviation for "scroll to a selected menu line and press the **SEL** button."
- A sequence of menu steps is represented by the menu names, separated by arrows (>).

▲ **INPUT > Timing Adjust > H Position**

... indicates the following sequence:

- a. From the **Main Menu**, select **INPUT** to display the **Input Menu**.
- b. Scroll to the **Timing Adjust** line and press **SEL** to display the **Timing Adjust Menu**.
- c. Scroll to the **H Position** line and press **SEL** to adjust the image's horizontal position.

---

## About the ACS-2048

The following topics are discussed in this section:

- [Overview](#)
- [Features](#)
- [What's New in Firmware Version 1.02](#)
- [A Word About HDCP](#)

### Overview

As the ideal peripheral for all Barco digital cinema installations, ACS-2048 is an 8 x 1 video switcher that accepts "universal" input formats, and outputs up to 12-bit DVI at 2048 x 1080. With a high-quality scaler at its core, upconverting any input format is as simple as "auto-acquiring" and selecting the desired input. However, disguised as a switcher, ACS-2048 is a pathway to new revenue streams for your facility. By enabling "alternate" content to be displayed in the digital cinema resolution, your theatre's role as a presentation facility for events, businesses, conventions and so much more — becomes a reality.

Please note:

- To ensure trouble-free installation and operation of your ACS-2048, please follow all procedures in the following two sections:
  - ~ Chapter 3, "[Installation](#)" on page 25.
  - ~ Chapter 4, "[Operation](#)" on page 31.
- Should you have any questions regarding the installation or operation of the ACS-2048 system, please consult with the factory. Refer to Appendix C, "[Contact Information](#)" on page 107 for contact details.

### Features

Major features of the ACS-2048 system are listed below:

- Supports "universal" inputs: HD-SDI, SD-SDI, DVI, Analog, Composite, and S-Video. All inputs support standard interlaced sources, and all input connectors are located on the front panel for user convenience.
- Provides motion adaptive de-interlacing and advanced noise reduction circuits.
- Provides an HDCP "decrypted input" and "encrypted output" path. This feature enables copy-protected content to be displayed at digital cinema resolutions, while maintaining copyright security. Refer to the "[A Word About HDCP](#)" section on page 15 for additional information.
- Provides twin-link 12-bit DVI outputs for upconverting all inputs to 2048 x 1080.
- Includes a user-friendly front panel and an intuitive menu display.
- Provides integration with the "Communicator" touch screen on Barco digital cinema projectors, enabling seamless remote control.
- Includes input file management plus a standard "Auto Acquire" mode.
- The output adjustment feature enables the entire output to be scaled to fit the actual theatre's physical setup (e.g., curtains, drapes, and off-axis projection).

# 1. Introduction

About the ACS-2048

- Provides low video delay:
  - ~ For interlaced sources, maximum video delay is 5 fields total from input to screen (3 in ACS-2048 + 2 in Projector).
  - ~ For progressive sources, maximum video delay is 4 fields total from input to screen (2 in ACS-2048 + 2 in Projector).

## What's New in Firmware Version 1.02

This section lists the new or modified features that have been implemented since the last revision of the ACS-2048 User's Guide. Reference links are provided for additional details.

- **Input Files**

The number of input files has been increased from one per input to a global pool of 64 files. This feature enables users to store more than one file for a given input. When managing files, users can select specific file numbers for the save, delete, and recall functions. In Chapter 4, refer to the ["Input Menu"](#) section on page 43 for information about this feature.

- **File Association Menu**

A **File Association** menu has been added to the **System Menu** that enables users to associate an input configuration file with each of the eight inputs. This function tells the system which file to use when an input is selected from the front panel. In Chapter 4, refer to the ["File Association"](#) section on page 64 for details.

- **Remote Commands**

New remote commands have been added to the ACS-2048's command library, and several commands have been modified:

- ~ **ICSAV**: modified command
- ~ **ICREC**: modified command
- ~ **ISEL**: modified command
- ~ **ICDEL**: new command
- ~ **IMAP**: new command
- ~ **ICLIST**: new command

In Appendix B, refer to the ["ACS-2048 Command List"](#) section for details.

- **New Input Formats**

The following input formats have been added in this release:

- ~ 1280x720@60
- ~ 1280x720 II@60
- ~ 1280x800@60
- ~ 1280x800 II@60
- ~ 1360x768@60
- ~ 1440x900@60
- ~ 1440x900@75
- ~ 1440x900@85
- ~ 1680x1050@60

In Appendix A, refer to the ["Input Format Table"](#) section on page 89 for the complete list of supported formats.

## A Word About HDCP

HDCP stands for **High-Bandwidth Digital Content Protection**, an industry-wide copy protection scheme that is used to prevent the potential interception of digital data between the source (e.g., a Blu-Ray player) and the target display (e.g., a digital cinema projector). The HDCP format was designed by Intel, and it uses an “authentication and key exchange” procedure to accomplish the required protection. For proper implementation, products that are compatible with the HDCP format require a secure connection to a compliant display, such as a digital cinema projector.

In digital cinema applications in which an ACS-2048 is used, when an HDCP compliant device is connected to the ACS-2048, an HDCP “session” is created. In this session (which is transparent to the user), “keys” are exchanged between the source device (e.g., a Blu-Ray player) and the digital cinema projector. The source device queries the display to ensure that the equipment is HDCP compliant before video is shown. Note that non-HDCP equipment such as PCs will work with any DVI compliant display, but HDCP compliant equipment only shows content on HDCP compliant displays.

Please note the following important points:

- When an HDCP compliant device is connected to the ACS-2048 and that specific input is selected, the **Status Menu** indicates if HDCP is enabled.
- If the “session” determines that the target display device is non-HDCP compliant (e.g., if the user is attempting to make an illegal copy on an external recorder), an error message appears on the ACS-2048’s **Status Menu**, indicating that video cannot be shown.
- HDCP compliant repeaters cannot be connected to the output of the ACS-2048, as the ACS-2048 *must* be the last device in the HDCP “chain” — prior to the HDCP compliant display device (projector). If an HDCP repeater is connected, the message “**HDCP Violation**” appears on the **Status Menu**. Refer to the “[Status Menu](#)” section on page 67 for additional details.

---

## Connectivity Diagram

The figure below illustrates a basic ACS-2048 system.

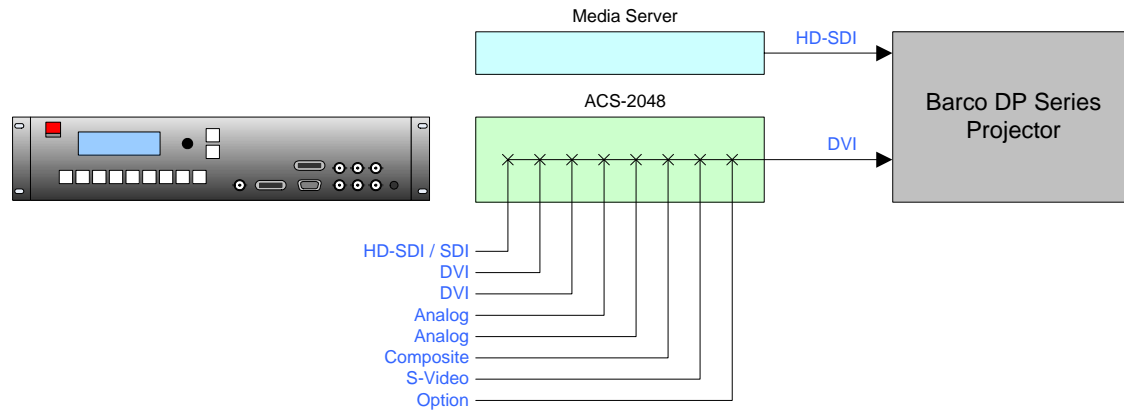

**Figure 1-1.** Block diagram, ACS-2048 system

In the diagram:

- Your selected media server connects to the Barco projector via dual-link HD-SDI.
- The ACS-2048 connects to the Barco projector via single link 8-bit DVI or twin-link 10/12-bit DVI.
- Eight dedicated inputs are available:
  - ~ 1 x SDI or HD-SDI, for serial digital or HD sources
  - ~ 2 x DVI, for computer sources. Note that these DVI connectors also support analog RGB inputs.
  - ~ 2 x Analog, for a variety of YUV and RGBHV sources
  - ~ 1 x composite, for composite NTSC or PAL video sources (e.g., DVD)
  - ~ 1 x S-Video, for encoded NTSC or PAL Y/C or S-Video sources
  - ~ 1 x Aux (not currently implemented)

In Chapter 2, refer to the "[Inputs Section](#)" heading on page 21 for details on all inputs.

---

## Application Questions

At Barco, we take pride in offering unique solutions to demanding technical problems. If you have application questions, require further information or would like to discuss your application requirements in more detail, please call (866) 469-8036. Our Customer Support Engineers will be happy to supply you with the support you need. Refer to Appendix C, "[Contact Information](#)" on page 107 for details.



## 2. Hardware Orientation

---

### In This Chapter

This chapter provides detailed diagrams of the ACS-2048's front and rear panels, along with comprehensive explanations of each.

The following topics are discussed:

- [ACS-2048 Front Panel](#)
- [ACS-2048 Rear Panel](#)

## 2. Hardware Orientation

### ACS-2048 Front Panel

## ACS-2048 Front Panel

The figure below illustrates the ACS-2048 front panel:

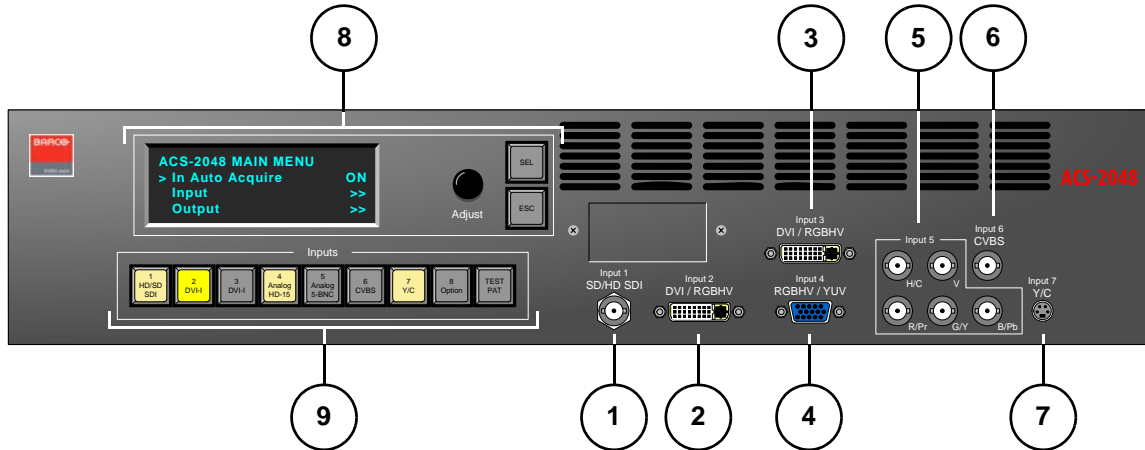

Figure 2-1. ACS-2048 Front Panel

1) <a href="#">Input 1 Connector</a>	4) <a href="#">Input 4 Connector</a>	7) <a href="#">Input 7 Connector</a>
2) <a href="#">Input 2 Connector</a>	5) <a href="#">Input 5 Connector</a>	8) <a href="#">Display Section</a>
3) <a href="#">Input 3 Connector</a>	6) <a href="#">Input 6 Connector</a>	9) <a href="#">Inputs Section</a>

Following are descriptions of each front panel section:

### 1) Input 1 Connector

One BNC connector is provided for **Input 1**, which corresponds to the first button in the **Inputs Section**. The input is dedicated to HD-SDI or SD-SDI. In Appendix A, refer to the [“Input Specifications”](#) section on page 82 for details.

### 2) Input 2 Connector

One DVI-I connector is provided for **Input 2**, which corresponds to the second button in the **Inputs Section**. The input is dedicated to an 8-bit digital input, or RGBHV data using the DVI connector’s analog pins.

#### Note

This input does not support analog composite, S-Video, or YUV formats.

In Appendix A, refer to the [“Input Specifications”](#) section on page 82 for specifications, and the [“DVI-I Connector Pinouts”](#) section on page 87 for pinouts.

### 3) Input 3 Connector

One DVI-I connector is provided for **Input 3**, which corresponds to the third button in the **Inputs Section**. This input is identical to **Input 2**.

### 4) Input 4 Connector

One HD-15 connector is provided for **Input 4**, which corresponds to the fourth button in the **Inputs Section**. The input is dedicated to YUV or RGBHV formats. Please note:

- ~ This input provides 10-bits/color sampling at a maximum 170 MHz.
- ~ This input supports 1:1 sampling up to 1600x1200@60 Hz. Sources with native pixel rates greater than 170 MHz will be filtered and undersampled at 170 Mhz. These include:
  - 1920x1080p@60 (173.0 MHz)
  - 1920x1200@60 (193.25 MHz)
  - 2048x1080p@60 (183.75 MHz)

#### Note

This input does not support Composite or S-Video formats.

In Chapter 3, refer to the “[Format Connection Table](#)” section on page 30 for a table of analog input combinations using a breakout cable. In Appendix A, refer to the “[Input Specifications](#)” section on page 82 for specifications, and the “[Analog 15-pin D Connector](#)” section on page 86 for pinouts.

### 5) Input 5 Connector

Five BNC connectors are provided for **Input 5**, which corresponds to the fifth button in the **Inputs Section**. This input is *almost* identical to **Input 4**, except that BNC connectors are used in place of the HD-15 connector.

### 6) Input 6 Connector

One BNC connector is provided for **Input 6**, which corresponds to the sixth button in the **Inputs Section**. The input is dedicated to Composite NTSC or PAL video. In Appendix A, refer to the “[Input Specifications](#)” section on page 82 for details.

### 7) Input 7 Connector

One 4-pin mini-DIN connector is provided for **Input 7**, which corresponds to the seventh button in the **Inputs Section**. The input is dedicated to encoded NTSC or PAL Y/C video. In Appendix A, refer to the “[Input Specifications](#)” section on page 82 for details, and the “[Mini-DIN Connector](#)” section on page 88 for pinouts.

### 8) Display Section

The **Display Section** includes the four-line display, the **ADJUST** knob and two “menu navigation” buttons: **SEL** and **ESC**. Refer to the “[Display Section](#)” heading on page 20 for complete details.

### 9) Inputs Section

The **Inputs Section** includes eight buttons that enable you to select inputs, plus a **TEST PAT** button that enables you to output a selected test pattern. Refer to the “[Inputs Section](#)” heading on page 21 for complete details.

## 2. Hardware Orientation

ACS-2048 Front Panel

### Display Section

The figure below illustrates the **Display Section**:

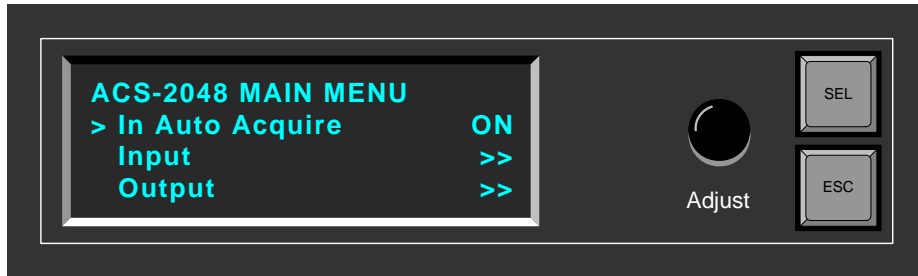

**Figure 2-2.** Display Section with Main Menu

Descriptions of each button and control are provided below:

- The **Menu Display** is a 4 line x 20 character Vacuum Fluorescent Display (VFD) that shows all ACS-2048 menus and sub-menus. Brightness is adjustable.



**Figure 2-3.** Sample Menu Display (Main Menu)

Please note:

- ~ The top line names the current menu, in all capital letters.
- ~ The navigation cursor (>) in the left-hand column indicates the current line on which action can be taken.
- ~ The double arrow (>>) indicates that a sub-menu is available.

In Chapter 4, refer to the "[Menu Tree](#)" section on page 35 for menu details.

- **ADJUST** — use the **Adjust Knob** to scroll through all system menus.
  - ~ Turn the knob counter-clockwise (**CCW**) to scroll down.
  - ~ Turn the knob clockwise (**CW**) to scroll up.
- **SEL** — press to enter a sub-menu, change a parameter, accept a parameter, or to answer "**Yes**" to certain menu queries.
- **ESC** — press to exit a menu without making changes, cancel an operation, or to answer "**No**" to certain menu queries. Each press takes you back up the menu tree by one level.

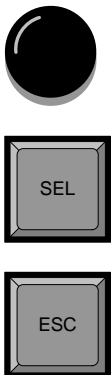

### Inputs Section

The figure below illustrates the **Inputs Section**:

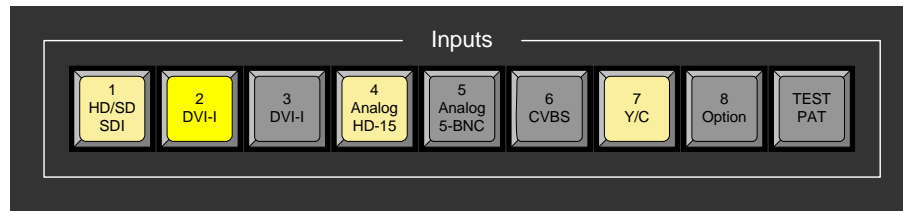

**Figure 2-4.** Inputs Section

The buttons in the **Inputs Section** enable you to select system inputs, or the built-in test pattern. There are four button states:



- **Off** — indicates that sync has not been detected on the input connector, and the input cannot be used on air.
- **Dim Yellow** — (or backlight on) indicates that sync has been detected, and the source is valid, and available for use on air.
- **Bright Yellow** — indicates the currently selected “on air” source.
- **Blinking** — indicates that sync has been lost from the current “on air” source. In this situation, internal black automatically replaces the previous on air source, and the source cannot be used on air until sync is restored.

Descriptions of each input button are provided below. When any valid input is selected, the button lights, and the input is routed to the output using a transition through black. The transition rate is adjustable in the **System Menu**.

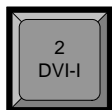
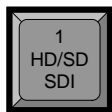

- **1** — selects an HD-SDI or SD-SDI input (the front panel **Input 1** connector) as the ACS-2048’s source.
- **2** — selects a digital DVI or analog RGBHV input (the front panel **Input 2** connector) as the source.

## 2. Hardware Orientation

### ACS-2048 Front Panel

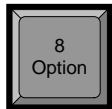
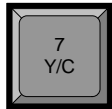
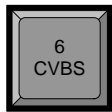
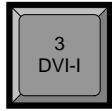

- **3** — selects a digital DVI or analog RGBHV input (the front panel **Input 3** connector) as the source.
- **4** — selects a YUV or RGBHV input (the front panel **Input 4** connector) as the source.
- **5** — selects a YUV or RGBHV input (the front panel **Input 5** connector) as the source.
- **6** — selects a Composite NTSC or PAL input (the front panel **Input 6** connector) as the source.
- **7** — selects an encoded NTSC or PAL Y/C input (the front panel **Input 7** connector) as the source.
- **8** — this input is currently not implemented.
- **TEST PAT** — selects the internal test pattern as the source.
  - There are two ways to use the **TEST PAT** button:
    - ~ When **TEST PAT** is pressed, the button lights, and the internal test pattern is routed to the output using a CUT transition. When another input is selected, the system transitions to the new input.
    - ~ When the **TEST PAT** button is already lit, press the **TEST PAT** button again to toggle back to the last selected input.

#### Note

If the **Menu Context** mode is **ON** in the **User Preference Menu**, the **Test Patterns Menu** appears whenever the **TEST PAT** button is pressed, allowing you to select an internal test pattern and adjust additional test pattern parameters.

In Chapter 4, refer to the [“Using Test Patterns”](#) section on page 71 for details.

# ACS-2048 Rear Panel

The figure below illustrates the ACS-2048 rear panel:

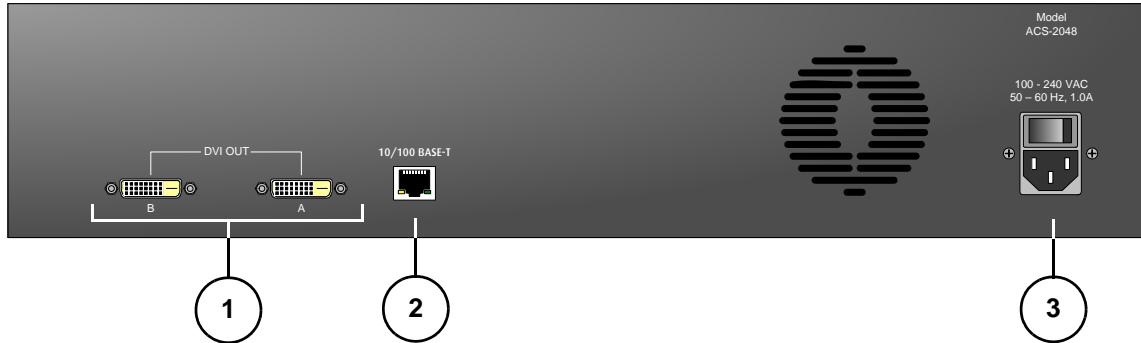

Figure 2-1. ACS-2048 Rear Panel

1) <a href="#">DVI Outputs</a>	3) <a href="#">AC Power</a>
2) <a href="#">Ethernet</a>	

Following are descriptions of each rear panel connector:

### 1) DVI Outputs

Two DVI-D connectors (**A** and **B**) are provided for the system's dual-channel (Twin-Link) DVI output. These outputs provides a 10-bit or 12-bit (4:4:4 RGB) signal as follows:

- ~ **Connector A:** 8 msb (most significant bit). Only 8-bit output mode can be selected on this connector, providing standard 8-bit DVI output.
- ~ **Connector B:** 2 or 4 lsb (least significant bit), depending on the output selection. To increase color depth, 10-bit or 12-bit output mode can be selected on this connector. Use the **Output Menu** to change the output mode and bit-width. In Chapter 4, refer to the "[Output Menu](#)" section on page 53 for details.

Please note:

- ~ In 10-bit or 12-bit mode, both outputs (A and B) must be connected to the projector. In 8-bit mode, a connection is required from Connector A only.
- ~ HDCP encryption is provided on both connectors A and B.
- ~ Frame rates of 50Hz and 59.94Hz are supported.

In Appendix A, refer to the "[Output Specifications](#)" section on page 83 for details, and the "[DVI-I Connector Pinouts](#)" section on page 87 for pinouts.

### 2) Ethernet

One RJ-45 connector is provided for 10/100BaseT **Ethernet** communications with the ACS-2048 system. The port is typically used for diagnostics or command-line operations via Telnet (using port 23).

▲ telnet 192.168.1.100 23

In Appendix A, refer to the "[Ethernet Connector](#)" section on page 88 for pinouts.

## 2. Hardware Orientation

ACS-2048 Rear Panel

### 3) AC Power

One **AC Connector** is provided for connecting ACS-2048 to AC. The integral switch turns the chassis on and off. In Appendix A, refer to the [“Physical and Electrical Specifications”](#) section on page 84 for power details.



## 3. Installation

---

### In This Chapter

This chapter provides detailed instructions for installing the ACS-2048 hardware. The following topics are discussed:

- [Safety Precautions](#)
- [Unpacking and Inspection](#)
- [Site Preparation](#)
- [Cable and Adapter Information](#)
- [Rack-Mount Installation](#)
- [Power Installation](#)
- [Signal Installation](#)
- [Format Connection Table](#)

### 3. Installation

#### Safety Precautions

---

## Safety Precautions

For all ACS-2048 installation procedures, observe the following important safety and handling rules to avoid damage to yourself and the equipment:

- To protect users from electric shock, ensure that the power supplies for each unit connect to earth via the ground wire provided in the AC power cord.
- The AC Socket-outlet should be installed near the equipment and be easily accessible.

---

## Unpacking and Inspection

Inspect the shipping box for damage. If you find any damage, notify the shipping carrier immediately for all claims adjustments. As you open the box, compare its contents against the packing slip. If you find any shortages, contact your Barco sales representative.

Once you have removed all the components from their packaging and checked that all the listed components are present, visually inspect each unit to ensure there was no damage during shipping. If there is damage, notify the shipping carrier immediately for all claims adjustments.

---

## Site Preparation

The environment in which you install your ACS-2048 should be clean, properly lit, free from static, and have adequate power, ventilation, and space for all components.

---

## Cable and Adapter Information

The table below provides information regarding supplied cables and adapters:

Table 3-1.

Cable / Adapter	Description	Quantity
AC Power Cord	7 foot, 10A	1
DVD-D Cable	3 meters. Connects ACS-2048 outputs to projector	2
Adapter	HDMI to DVI	1

---

## Rack-Mount Installation

ACS-2048 units are designed to be rack mounted and are supplied with front rack-mount hardware. Please note the following important points:

- When rack mounting the unit, remember that the maximum ambient operating temperature for the unit is 40 degrees C.
- Leave sufficient front and rear space to ensure that the airflow through the fan and vent holes is not restricted.
- When installing equipment into a rack, distribute the units evenly to prevent hazardous conditions that may be created by uneven weight distribution.
- Connect the unit only to a properly rated supply circuit.
- Reliable grounding (earthing) of rack-mounted equipment should be maintained.
- Rack mount the unit from the front rack ears using four rack screws (not supplied). Rack threads may be metric or otherwise — depending upon the rack type.
- Install the *lower* of the two mounting holes first.

---

## Power Installation

- Use the following steps to install power to the ACS-2048:
  1. Connect an AC power cord to the AC Power Connector on the rear of the ACS-2048, and then to an AC outlet.
  2. Connect AC Power cords (or AC adapters) to all peripheral equipment, such as video sources and PCs. Please note:
    - ~ Connect each unit only to a properly rated supply circuit.
    - ~ Reliable grounding of rack-mounted equipment should be maintained.

### 3. Installation

#### Power Installation

## Power Cord/Line Voltage Selection

ACS-2048 is rated to operate with the following specifications:

- **Input Power:** 100-240 VAC, 50-60 Hz
- **Power Consumption:** 240 watts maximum

ACS-2048 performs line voltage selection automatically, and no user controls are required. The AC power cords must be accessible so that they can be removed during field servicing.



#### Warning

When the ACS-2048 is used in the 230-volt mode, a UL listed line cord rated for 250 volts at 15 amps must be used and must conform to IEC-227 and IEC-245 standards. This cord will be fitted with a tandem prong-type plug.

The rear panel ON/OFF switch does not disconnect the unit from input AC power. To facilitate disconnection of AC power, the power cord must be connected to an accessible outlet near the unit.

Building Branch Circuit Protection: For 115 V use 20 A, for 230 V use 8 A.



Figure 3-1. Tandem Prong-type Plug

#### Avertissement

La choix de la ligne de voltage se réalise automatiquement par le ACS-2048 Transformateur Graphique. On n'a pas besoin du controller usager pour la choix de la ligne de voltage.

#### Warnung

Das ACS-2048 gerät mu beim Anschlu an 240V ~ mit einer vom VDE auf 250V/10A geprüften Netzleitung mit einem Schukostecker ausgestattet sein.

## Signal Installation

The figure below illustrates a sample ACS-2048 system diagram. Use this figure for reference during the signal installation process.

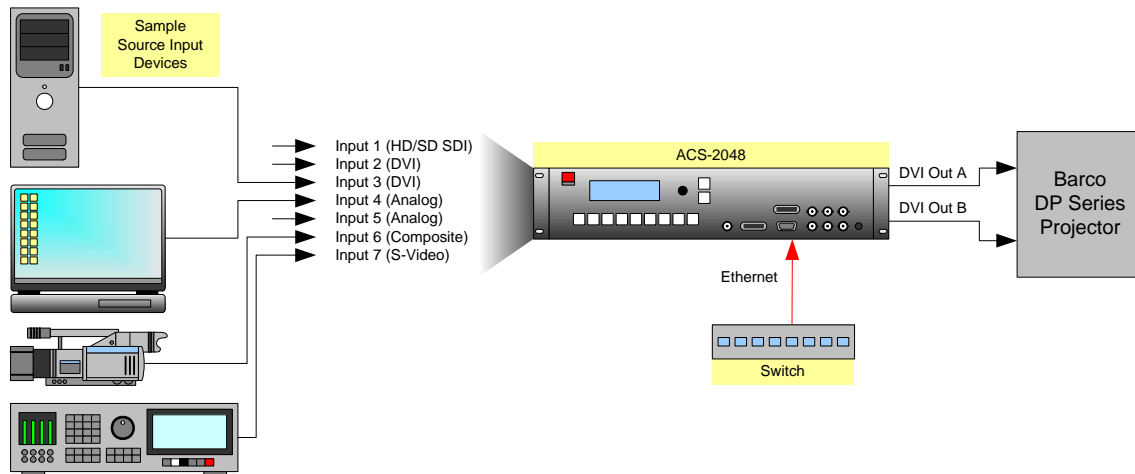

Figure 3-2. ACS-2048 System Diagram (sample)

- Use the following steps to install signals to/from the ACS-2048:

1. **Input connections** — any combination of inputs can be connected. If the system detects valid sync on the input signal, the associated front panel input button will light dim (backlight enabled). If sync is not detected, the button will not light.
  - a. Connect an HD-SDI or SD-SDI source to the **Input 1** connector (e.g., from an SDI camera or SDI server).
  - b. Connect a digital DVI or analog RGBHV source to the **Input 2** connector (e.g., from a laptop or PC). This input does not support Composite, S-Video, or YUV formats.
  - c. Connect a digital DVI or analog RGBHV source to the **Input 3** connector. Inputs 2 and 3 are identical. This input does not support Composite, S-Video, or YUV formats.
  - d. Connect a YUV or RGBHV source to the **Input 4** connector (e.g., from a YUV or RGB source, or a laptop). This input does not support Composite or S-Video formats. Refer to the [“Format Connection Table”](#) section on page 30 for a table of analog input combinations.
  - e. Connect a YUV or RGBHV source to the **Input 5** connector. Inputs 4 and 5 are identical. This input does not support Composite or S-Video formats. Refer to the [“Format Connection Table”](#) section on page 30 for a table of analog input combinations.
  - f. Connect a Composite NTSC or PAL source to the **Input 6** connector (e.g., from an analog camera).
  - g. Connect an encoded NTSC or PAL Y/C source to the **Input 7** connector (e.g., from an S-Video source, such as a DVD player).

### Note

**Input 8** is currently not implemented.

### 3. Installation

#### Format Connection Table

#### 2. Output connections:

- a. If you are operating the ACS-2048 in 10-bit or 12-bit mode, connect both DVI outputs (A and B) to the projector's DVI inputs A and B.
- b. If you are operating the ACS-2048 in 8-bit mode, connect DVI output A to the projector's DVI input A.

#### 3. Communications connection:

- a. Connect the ACS-2048's Ethernet port to an Ethernet switch, and connect the switch to the other Ethernet devices in your local system (e.g., laptop, projector, etc.). This connection enables you to communicate with the ACS-2048 via Telnet. In Appendix B, refer to the "[Communicating with ACS-2048](#)" section on page 93 for details.

This completes system signal installation. Please continue with system setup, menu orientation and operations, as outlined in Chapter 4, "[Operation](#)" on page 31.

## Format Connection Table

Use the following table to connect various source formats to the ACS-2048, using the universal input connectors (on **Input 4** and **Input 5**) in conjunction with a customer supplied VGA to 5 x BNC breakout cable. Please note:

- **RGB format** — typical devices: Computers
- **YUV or YP<sub>b</sub>P<sub>r</sub> (Betacam) format** — typical devices: DVD player, Betacam deck

#### Important

Inputs **4** and **5** do not support Composite or S-Video formats.

Using a customer supplied VGA to 5 x BNC breakout cable, multiple input combinations are possible. Cells with checks denote the connections required for the indicated format.

#### Note

For RGB with H and V sync, use the VGA connector directly (**Input 4**), or all five BNCs (**Input 5**).

**Table 3-2.** Analog Input Combinations using Breakout Cable

Breakout Cable Wire Color	YUV (YP <sub>b</sub> P <sub>r</sub> )	RGB Sync on Green	RGB Comp Sync	RGB Separate H V
R	✓ (P <sub>r</sub> )	✓	✓	✓
G	✓ (Lum)	✓	✓	✓
B	✓ (P <sub>b</sub> )	✓	✓	✓
H Sync			✓	✓
V Sync				✓

Please contact **Barco Technical Support** for information on obtaining breakout cables. In Appendix C, refer to the "[Contact Information](#)" section on page 108 for details.

## 4. Operation

---

### In This Chapter

This chapter provides comprehensive menu descriptions and detailed operating instructions for the ACS-2048. The following topics are discussed:

- [Control Overview](#)
- [Power-Up Initialization](#)
- [Quick Setup and Operations](#)
- [Menu Tree](#)
- [Quick Function Reference](#)
- [Using the Main Menu](#)
- [Using Inputs](#)
- [Using Test Patterns](#)
- [Front Panel Lockout](#)

## 4. Operation

### Control Overview

---

## Control Overview

There are several ways to control the ACS-2048:

- The front panel is ideal for all basic system configurations. Available controls include the **Display Section** and the buttons in the **Inputs Section**.
- The ACS-2048 can also be controlled remotely via Ethernet. All system commands are available. Typically, remote commands are used to switch inputs from the Barco projector's "Communicator" touch screen, but more advanced interfaces can be configured using the protocol. Refer to [Appendix B](#) on page 93 for additional details.

---

## Power-Up Initialization

After connecting power to the ACS-2048, locate the power switch on the back of the chassis, and turn the power **ON**. While the system is initializing, the following messages are displayed:

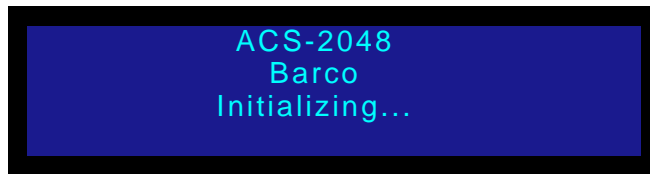

Figure 4-1. System initialization message 1

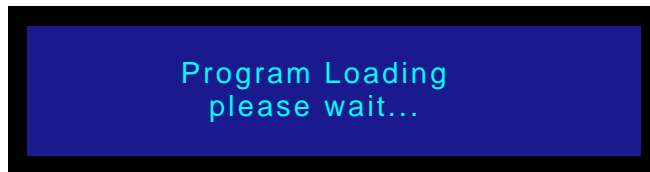

Figure 4-2. System initialization message 2

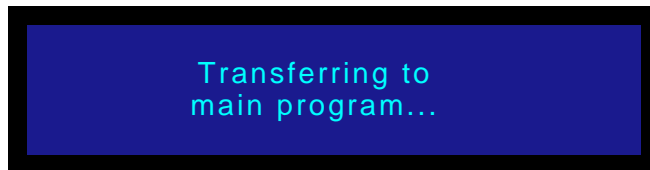

Figure 4-3. System initialization message 3



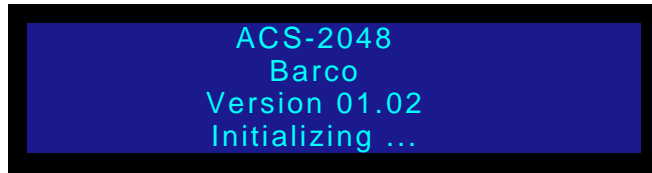

Figure 4-4. System initialization message 4

The “version” line in the above menu shows the software version that is currently being executed. This version number will change as software upgrades are released.

---

## Quick Setup and Operations

For the optimum speed in system setup and operations, use the following steps. For reference, links are provided to pertinent sections in this guide.

1. **Determine output mode** — Determine the output operating mode of the ACS-2048, and connect output cables accordingly:
  - ~ If you elect to operate in 8-bit mode, ensure that Output Connector A is connected to the projector’s DVI input A.
  - ~ If you elect to operate in 10-bit or 12-bit mode, ensure that output Connectors A and B are connected to the projector’s DVI inputs A and B.

In Chapter 2, refer to the “[ACS-2048 Rear Panel](#)” section on page 23.

2. **Connect power** — Ensure that power is properly connected to the ACS-2048. In (Chapter 3, “[Power Installation](#)” on page 27.)
3. **Connect Ethernet** — Ensure that Ethernet is properly connected to the ACS-2048. (Chapter 3, “[Signal Installation](#)” on page 29.)
4. **Turn on power** — Turn on power to the ACS-2048, your projector, and to all peripheral devices as required. (This chapter, “[Power-Up Initialization](#)” on page 32.)
5. **Set output format** — Set the desired output format. There are two choices:
  - ~ 2048x1080p @ 59.94Hz
  - ~ 2048x1080p @ 50Hz

(This chapter, “[Output Format](#)” on page 53.)

6. **Set output mode** — Set the desired output mode to 8-bit, 10-bit or 12-bit. (This chapter, “[Output Mode](#)” on page 53.)
7. **Adjust output** — As required, scale the output to fit the actual projected image. (This chapter, “[Output Adjust](#)” on page 55.)
8. **Save output configuration** — After completing all output adjustments, save the output configuration. (This chapter, “[Save Output Config](#)” on page 56.)
9. **Enable test pattern** — Turn on the desired test pattern, and verify that you have an image on your projector. When complete, turn off the test pattern. (This chapter, “[Test Pattern](#)” on page 54.)

## 4. Operation

### Quick Setup and Operations

10. **Connect inputs** — Connect all inputs to the ACS-2048, and check for the proper backlight, which indicates that sync is detected. (Chapter 3, “[Signal Installation](#)” on page 29. This chapter, “[Understanding Backlighting](#)” on page 69.)
11. **Select and adjust inputs** — As required, select an input, and perform the necessary adjustments, such as crop, brightness, contrast, color balance, and timing. (This chapter, “[Input Menu](#)” on page 43.)
12. **Save input configuration** — After completing all adjustments for an input, select a file number and save the input configuration. (This chapter, “[Save Input Config](#)” on page 51.)
13. **Repeat for each input** — repeat steps 10 and 11 for each input that you have connected to the ACS-2048.
14. **Adjust system parameters** — As required, adjust all desired system parameters such as transition time, display brightness, and your user preferences. (This chapter, “[System Menu](#)” on page 57.)
15. **Save system configuration** — After completing all system adjustments, save the system configuration. (This chapter, “[Save System Config](#)” on page 65.)
16. **Ready to roll** — With all output, input and system configurations saved, press the desired input button, and begin your presentation. Ensure that the button is lit, indicating that the signal is valid.

#### Note

For advanced system operations, specific system “tweaks” and operating descriptions on every feature, please start with the “[Quick Function Reference](#)” section on page 38, and select the function that you wish to perform.

# Menu Tree

The figure below illustrates the entire ACS-2048 menu tree. Please use this diagram for reference as you learn how to operate the system.

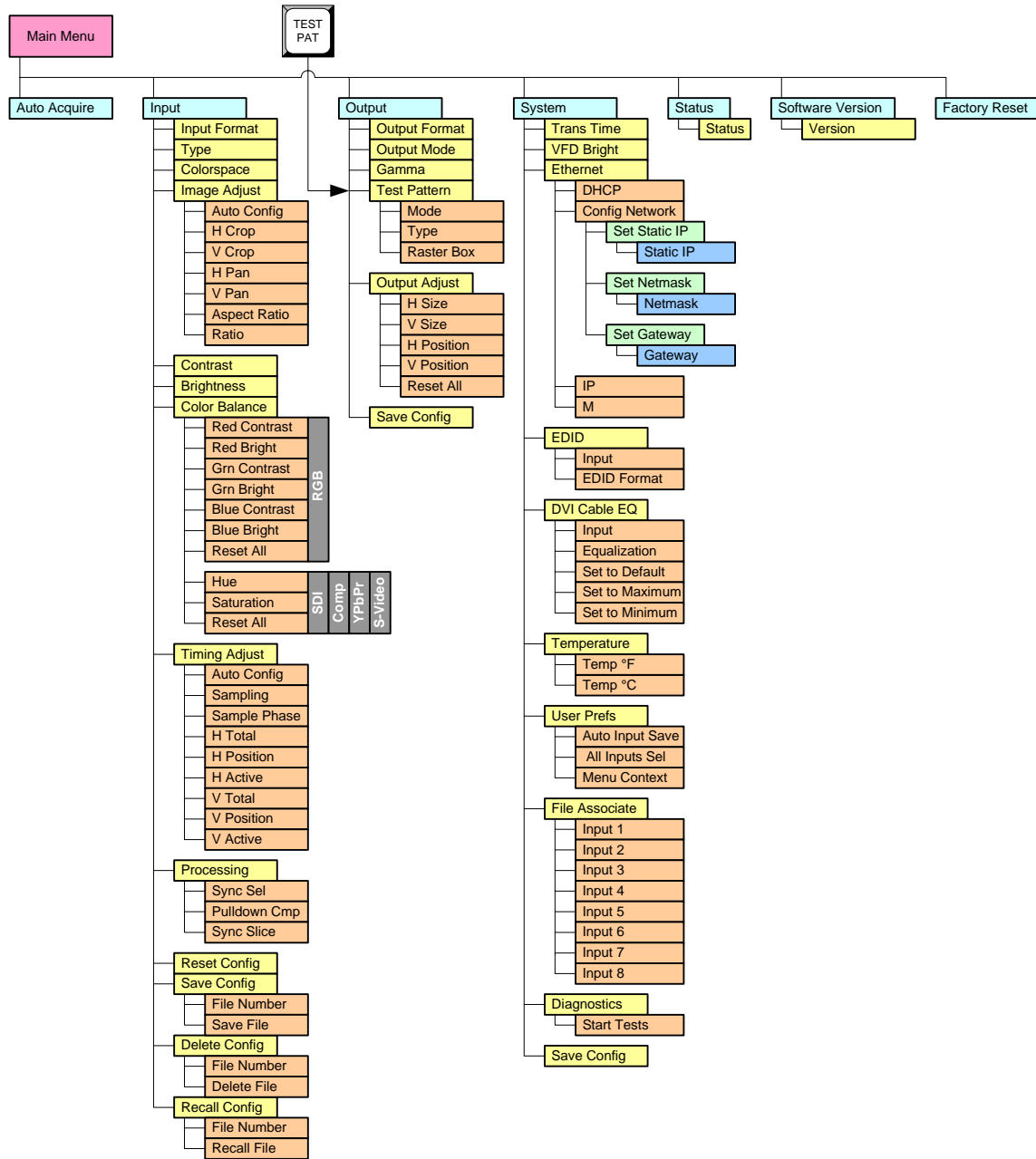

Figure 4-5. ACS-2048 Menu Tree

## 4. Operation

### Using the Menu System

---

## Using the Menu System

This section lists the rules and conventions for using ACS-2048's menu system. For reference, the figure below illustrates the **Main Menu**:



**Figure 4-6.** Main Menu Display

Please note the following important menu rules and conventions:

- The top line names the current menu, in all capital letters.
- Subsequent lines typically display two fields:
  - ~ For a listed **function**, the left-hand field names the function, and the right-hand field is the function's current parameter (or value).
  - ~ For a listed **sub-menu**, the left-hand field names the sub-menu that you can access, and the right-hand field displays the double arrow (>>), indicating that a sub-menu is available.
- The “navigation” **cursor** (>) in the left-hand column indicates the current line on which action can be taken. This arrow “scrolls” as you rotate the knob.
- Scrolling:
  - ~ Turn the **ADJUST** knob counter-clockwise (**CCW**) to scroll down.
  - ~ Turn the **ADJUST** knob clockwise (**CW**) to scroll up.
- To enter a sub-menu, scroll to the desired line and press **SEL**.

#### Note

Throughout this chapter, the term “**select**” is used as an abbreviation for “scroll to a selected menu line and press the **SEL** button.”

▲ Select the **Input** field to ...

- To change a parameter, scroll to the desired line and press **SEL**. The cursor changes to the “edit” cursor (#). Use the **ADJUST** knob to modify the value:
  - ~ Turn the **ADJUST** knob **CW** to increase a value.
  - ~ Turn the **ADJUST** knob **CCW** to decrease a value.
- To accept a parameter or value, press **SEL**. The edit cursor changes back to the navigation cursor.

#### Note

You must press **SEL** to activate an ACS-2048 function.

- In the “edit” mode, to exit (or cancel) without changing the original parameter, press **ESC**.

## 4. Operation

### Using the Menu System

- To navigate back up the menu structure, press **ESC**. Each press takes you back up the menu tree by one level.
- The **SEL** button is also used to answer “**Yes**” to certain menu queries. The **ESC** button is also used to answer “**No**” to certain menu queries.

#### Note

The display itself is four lines high, and the **ADJUST** knob is used to scroll through the various lines. Throughout this chapter, *entire* menus will be shown for clarity — rather than a series of four-line sections.

- If a value is displayed between brackets, (e.g., **[SMPTE]**) this indicates that the value can not be changed.

## 4. Operation

### Quick Function Reference

---

## Quick Function Reference

Use the following table to quickly access the proper menu for a specific function. Both hyperlinks and page numbers are provided.

**Table 4-1.** ACS-2048 Quick Function Reference Table

How to:	Use the Following Section:	Page
Adjust color balance	<a href="#">Color Balance</a>	47
Adjust display brightness	<a href="#">VFD Brightness</a>	58
Adjust H Total, Position, Active	<a href="#">Timing Adjust</a>	48
Adjust image aspect ratio	<a href="#">Image Adjust</a>	46
Adjust image brightness	<a href="#">Brightness</a>	47
Adjust image contrast	<a href="#">Contrast</a>	47
Adjust image processing	<a href="#">Processing</a>	50
Adjust image timing	<a href="#">Timing Adjust</a>	48
Adjust input colorspace	<a href="#">Colorspace</a>	45
Adjust input format	<a href="#">Input Format</a>	44
Adjust output format	<a href="#">Output Format</a>	53
Adjust output gamma	<a href="#">Gamma</a>	54
Adjust output size / position	<a href="#">Output Adjust</a>	55
Adjust pulldown comp	<a href="#">Processing</a>	50
Adjust sample phase	<a href="#">Timing Adjust</a>	48
Adjust sync selection	<a href="#">Processing</a>	50
Adjust sync slice	<a href="#">Processing</a>	50
Adjust the image	<a href="#">Image Adjust</a>	46
Adjust transition time	<a href="#">Trans Time</a>	57
Adjust V Total, Position, Active	<a href="#">Timing Adjust</a>	48
Associate inputs with files	<a href="#">File Association</a>	64
Auto acquire inputs	<a href="#">In Auto Acquire</a>	42
Change color balance	<a href="#">Color Balance</a>	47
Change display brightness	<a href="#">VFD Brightness</a>	58
Change DVI cable equalization	<a href="#">DVI Cable Equalization</a>	62
Change EDID DVI format	<a href="#">EDID DVI Input Format</a>	60
Change Ethernet parameters	<a href="#">Ethernet</a>	58
Change image aspect ratio	<a href="#">Image Adjust</a>	46

## 4. Operation

### Quick Function Reference

**Table 4-1.** ACS-2048 Quick Function Reference Table (Continued)

How to:	Use the Following Section:	Page
Change image brightness	<a href="#">Brightness</a>	47
Change image contrast	<a href="#">Contrast</a>	47
Change image processing	<a href="#">Processing</a>	50
Change image timing	<a href="#">Timing Adjust</a>	48
Change input colorspace	<a href="#">Colorspace</a>	45
Change input format	<a href="#">Input Format</a>	44
Change input type	<a href="#">Type</a>	44
Change output format	<a href="#">Output Format</a>	53
Change output gamma	<a href="#">Gamma</a>	54
Change output mode (8-bit, 10-bit, 12-bit)	<a href="#">Output Mode</a>	53
Change sampling (1:1, Oversample)	<a href="#">Timing Adjust</a>	48
Change test pattern type	<a href="#">Test Pattern</a>	54
Change transition time	<a href="#">Trans Time</a>	57
Change user preferences	<a href="#">User Preference</a>	63
Check system temperature	<a href="#">Temperature</a>	62
Configure Ethernet network	<a href="#">Ethernet</a>	58
Create input file association	<a href="#">File Association</a>	64
Crop the image	<a href="#">Image Adjust</a>	46
Delete input configuration	<a href="#">Delete Config</a>	52
Display software version	<a href="#">Software Version</a>	68
Display system status	<a href="#">Status Menu</a>	67
Enable or disable all input select	<a href="#">User Preference</a>	63
Enable or disable auto input save	<a href="#">User Preference</a>	63
Enable or disable DHCP	<a href="#">Ethernet</a>	58
Enable or disable menu context mode	<a href="#">User Preference</a>	63
Enable or disable raster box	<a href="#">Test Pattern</a>	54
Enable or disable test patterns	<a href="#">Test Pattern</a>	54
Enable or disable Auto Acquire mode	<a href="#">In Auto Acquire</a>	42
Equalize DVI cables	<a href="#">DVI Cable Equalization</a>	62
Lock out front panel	<a href="#">Front Panel Lockout</a>	72
Navigate the Menu Tree	<a href="#">Menu Tree</a>	35
Pan the image	<a href="#">Image Adjust</a>	46
Perform factory reset	<a href="#">Factory Reset</a>	68

## 4. Operation

### Quick Function Reference

**Table 4-1.** ACS-2048 Quick Function Reference Table (Continued)

<b>How to:</b>	<b>Use the Following Section:</b>	<b>Page</b>
Perform quick setup and operations	<a href="#">Quick Setup and Operations</a>	33
Program EDID	<a href="#">EDID DVI Input Format</a>	60
Reset input configuration	<a href="#">Reset Config</a>	50
Reset to factory default	<a href="#">Factory Reset</a>	68
Run system diagnostics	<a href="#">Diagnostics</a>	65
Save input configuration	<a href="#">Save Input Config</a>	51
Save output configuration	<a href="#">Save Output Config</a>	56
Save system configuration	<a href="#">Save System Config</a>	65
Select inputs	<a href="#">Input Selection Rules</a>	69
Set Ethernet gateway	<a href="#">Ethernet</a>	58
Set Ethernet netmask	<a href="#">Ethernet</a>	58
Set Ethernet static IP address	<a href="#">Ethernet</a>	58
Set user preferences	<a href="#">User Preference</a>	63
Turn on system power	<a href="#">Power-Up Initialization</a>	32
Understand auto acquire	<a href="#">Understanding Auto Acquire</a>	70
Understand button backlighting	<a href="#">Understanding Backlighting</a>	69
Understand input selection rules	<a href="#">Input Selection Rules</a>	69
Use front panel lockout mode	<a href="#">Front Panel Lockout</a>	72
Use inputs	<a href="#">Using Inputs</a>	69
Use test patterns	<a href="#">Using Test Patterns</a>	71
Use the Input Menu	<a href="#">Input Menu</a>	43
Use the Main Menu	<a href="#">Using the Main Menu</a>	41
Use the menu system	<a href="#">Using the Menu System</a>	36
Use the SEL and ESC knobs	<a href="#">Using the Menu System</a>	36
View software version	<a href="#">Software Version</a>	68
View system status	<a href="#">Status Menu</a>	67



---

## Using the Main Menu

After ACS-2048 initialization is complete, the **Main Menu** appears, which is the system's top-level menu. Please note:

- When you make changes to input, output and system parameters, configuration information can be stored in non-volatile memory — provided that the user performs the three “**Save Config**” functions. When a configuration file is saved, the settings will be recalled automatically each time the unit is turned on.
- There are three different “**Save Config**” functions:
  - ~ The **Save Config** function on the **Input Menu** saves a configuration for the currently selected input in non-volatile memory. Note that if the “**Auto Input Save**” function is enabled in the **User Preferences Menu**, the system *automatically* saves inputs.
  - ~ The **Save Config** function on the **Output Menu** saves all output configuration parameters in non-volatile memory.
  - ~ The **Save Config** function on the **System Menu** saves all system configuration parameters in non-volatile memory.



Figure 4-7. Main Menu

Following are descriptions of each **Main Menu** function:

- [In Auto Acquire](#)
- [Input Menu](#)
- [Output Menu](#)
- [System Menu](#)
- [Status Menu](#)
- [Software Version](#)
- [Factory Reset](#)

## 4. Operation

Using the Main Menu

### In Auto Acquire

From the **Main Menu**, select **In Auto Acquire** to enable or disable the **Input Auto Acquire** mode. Values are: **OFF** and **ON** (default).

- When **In Auto Acquire** is **ON**, the system always performs a full sync acquisition on the selected input signal under the following conditions:
  - ~ When an input channel *without* a saved configuration file is selected.
  - ~ When the input type is changed.
  - ~ When the input signal changes sync rates.
  - ~ When an input *with* a saved configuration file is selected, but the input timing is different from the saved configuration.
- When **In Auto Acquire** is **OFF**, the system first uses the “associated” input file configuration for each input channel (to the greatest extent possible). At some point, the input signal may be too far away from the saved configuration, in which case a good input lock may not be possible.

Please note the following important points:

- It is recommended that you leave the **In Auto Acquire** mode **ON**. In this mode, if the timing changes on any of your inputs (whether or not you have a saved configuration file), you will always get an output image. On the other hand, if the mode is **OFF** and the timing of an input changes, the output will be black.
- When the **In Auto Acquire** mode is **ON**, the ACS-2048 automatically detects and acquires the input video type and resolution (in most cases), and limits menu selections as applicable to the detected video type (e.g., color space).
- If you are an advanced user and you know the exact timing parameters for your input(s), you can turn the **In Auto Acquire** mode **OFF**, and dial in your timing parameters manually.

#### Tip

If you have already saved configuration files for your input sources, it is recommended that you turn the **In Auto Acquire** mode **OFF**. This mode provides the fastest transition times. When the mode is **ON**, transition times will be greater, due to the additional time required to analyze the input timing for each selected source.

Refer to the “[Understanding Auto Acquire](#)” section on page 70 for additional information.

## Input Menu

From the **Main Menu**, select **Input** to display the **Input Menu**.

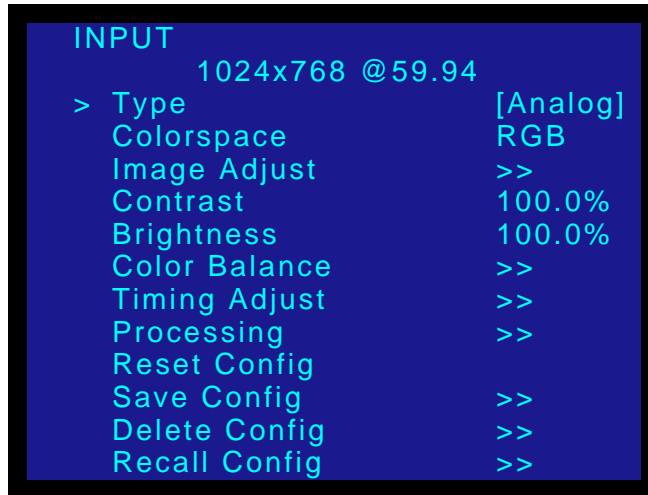

Figure 4-8. Input Menu (sample)

The **Input Menu** enables you to set configuration options for the selected input channel. The menu can be used in two ways:

- Select an input button *first*, then use the menu to set all input parameters.
- While you are already in the **Input Menu**, select a *different* input button. In this case, the menu fields update to reflect the values for the newly selected input.

**Note**

Changing entries for one input will not affect the configuration of the other input channels.

Following are descriptions of each **Input Menu** function:

- [Input Format](#)
- [Type](#)
- [Colospace](#)
- [Image Adjust](#)
- [Contrast](#)
- [Brightness](#)
- [Color Balance](#)
- [Timing Adjust](#)
- [Processing](#)
- [Reset Config](#)
- [Save Input Config](#)
- [Delete Config](#)
- [Recall Config](#)

## 4. Operation

### Using the Main Menu

#### Input Format

From the **Input Menu**, select the top **Input Format** line to view the “auto-acquired” format for the selected input, or to change the format. The format is shown in the following form:

**Hact x Vact @ Vr Hz**

▲ 1024x768@59.94

Please note the following important points:

- If you select an input and it does not have a valid input signal, the **"Invalid Selection, No Sync Detected"** message is displayed.
- If an input was previously valid, and its video signal (or sync) is lost, the button blinks and the **"Invalid Signal"** message is displayed.
- When **In Auto Acquire** is **ON**, the input video format will be detected in the following search order:
  - ~ Saved “file association” for the selected input channel
  - ~ Any saved input configuration
  - ~ Standard library formats
  - ~ Best guess (to the closest video format in the library).
- If the video format is a “best guess” as determined by the “auto acquire” mode, it is displayed (only in the **Status Menu**) within asterisks.
  - ▲ \*1024x768@60.11\*
- If you select an input that has been saved (using the **Save Config** function), the video format is displayed (only in the **Status Menu**) within brackets.
  - ▲ [1024x768@59.94] This example is a saved “exact match” from the format table (or library).
  - ▲ [\*1024x768@59.90\*] This example is a saved “best guess.”
- When **In Auto Acquire** is **OFF**, the system attempts to lock to the signal using the “associated” input configuration file. If the associated file does not match the input signal for the selected channel, the output remains black, and the display indicates **"Invalid Signal."**

#### Note

When you save an input using the **Save Config** function, the system automatically creates a file association. Refer to the [“Save Input Config”](#) section on page 51 and the [“File Association”](#) section on page 64 for details.

#### Type

In the **Input Menu**, the “information only” **Type** field shows the selected input type between brackets. The available input types that will be shown depend on the selected input button:

- For input 1: **[SDI]**
- For inputs 2 and 3: **[DVI]** or **[Analog]**. The ACS-2048 automatically detects the type of input signal, and selects the correct type.

#### Note

If both analog and digital inputs are connected simultaneously (via customer-supplied “Y” cable), the system defaults to DVI.

- For inputs 4 and 5: **[Analog]**
- For input 6: **[CVBS]**
- For input 7: **[Y/C]**

Please note:

- If a source type is chosen and a correct signal cannot be detected, the **Input Format** field (in the **Input Menu** and the **Status Menu**) indicates “**Invalid Signal.**”
- For inputs 2 and 3, analog signals can be connected to the ACS-2048 using a customer-supplied DVI to HD-15 adaptor.

## Colorspace

From the **Input Menu**, select **Colorspace** to change the color space for the selected input. Values depend on the selected input:

- For input 1: **[SMPTE]**
- For input 2: **RGB, SMPTE**
- For input 3: **RGB, SMPTE**
- For input 4: **RGB, SMPTE**
- For input 5: **RGB, SMPTE**
- For input 6: **[SMPTE]**
- For input 7: **[SMPTE]**

Please note:

- The default selection for **Y<sub>P</sub>bP<sub>r</sub>** or **YUV** is **SMPTE**. In Appendix A, refer to the “**Input Format Table**” section on page 89 for information on the formats that are **RGB**, **SMPTE** or both. When both **RGB** and **SMPTE** are listed, the first item in the list is the default.
- When the input is analog (including **CVBS**, **Y/C** or **DVI**), you can select between **RGB** and **SMPTE**.
- When the following formats are detected as **SD/SDI** or **HD/SDI**, only **[SMPTE]** is shown, and this color space is unchangeable.

~ NTSC (480i)	~ 1920x1080p @29.97
~ PAL (576i)	~ 1920x1080p @30
~ 1280x720p @50	~ 1920x1080sF@23.98
~ 1280x720p @59.94	~ 1920x1080sF@24
~ 1280x720p @60	~ 1920x1080i @50
~ 1920x1080p @23.98	~ 1920x1080i @59.94
~ 1920x1080p @24	~ 1920x1080i @60
~ 1920x1080p @25	

## 4. Operation

### Using the Main Menu

#### Image Adjust

From the **Input Menu**, select **Image Adjust** to display the **Image Adjust Menu**. This menu enables you to adjust input parameters such as crop, pan and aspect ratio:



Figure 4-9. Image Adjust Menu (sample)

- Select **Auto Config** to perform an automatic input configuration on the selected source. In this mode, the system finds the first and last pixel on each edge, and ensures (to the best possible extent) that the entire image is visible. In addition, if the input is analog, the system automatically phases the input to determine the correct sampling phase.

The **Crop** and **Pan** functions allow you to crop off unwanted video (e.g., black edges), and then position the cropped image as desired within the selected aspect ratio.

- Select **H Crop** to crop both the left and right edges simultaneously. Values are in pixels. The output “window” is maintained in both size and aspect ratio.
- Select **V Crop** to crop both the top and bottom edges simultaneously. Values are in lines. The output “window” is maintained in both size and aspect ratio.

#### Note

For both **H Crop** and **V Crop**, the function always cuts *into* the visible image, and never exposes any video outside the source’s active area. In addition, as you crop, the ACS-2048 always scales the input back up to fit the selected aspect ratio within the system’s 2048 x 1080 output window.

- Select **H Pan** to pan a cropped image left and right — within the selected aspect ratio. Values are in pixels. Note that the value reads **[0]** if the image has not been cropped horizontally.
- Select **V Pan** to pan a cropped image up and down — within the selected aspect ratio. Values are in lines. Note that the value reads **[0]** if the image has not been cropped vertically.

The **Aspect Ratio** function allows you to set a pre-defined or custom ratio for the input.

- Select **Aspect Ratio** to adjust the image to one of the following values: **1:1, 3:2, 4:3, 5:4, 16:9, Custom**
- The **Ratio** line is only visible when **Custom** is selected:

## 4. Operation

Using the Main Menu

- ~ **Adjustment range:** 0.750 to 3.000. Note that the default value depends on the last **Aspect Ratio** selected before **Custom** was chosen.

### Note

The ACS-2048 selects and displays the input video aspect ratio according to the input format detected. For example:

- ▲ Computer video at 1280x1024@60Hz defaults to 5:4 aspect ratio
- ▲ NTSC video defaults to 4:3
- ▲ HDTV 1080i video defaults to 16:9

### Contrast

From the **Input Menu**, select **Contrast** to change the contrast of the selected input.

- **Adjustment range:** 75.0% to 125.0%
- **Default:** 100%

### Brightness

From the **Input Menu**, select **Brightness** to change the brightness of the selected input.

- **Adjustment range:** 75.0% to 125.0%
- **Default:** 100%

### Color Balance

From the **Input Menu**, select **Color Balance** to display one of two available **Color Balance Menus**. The menu that is shown depends on the current input's selected type. Each menu allows you to adjust the input's color balance parameters.

- [RGB Color Balance Menu](#)
- [Hue/Saturation Color Balance Menu](#)

#### RGB Color Balance Menu

If the current input's type is set to **RGB**, the **RGB Color Balance Menu** appears:



Figure 4-10. RGB Color Balance Menu (sample)

Each of the individual contrast and brightness settings operates in conjunction with the "global" contrast and brightness settings in the **Input Menu**.

- **Adjustment range** (all values): -25.0% to +25.0%

## 4. Operation

Using the Main Menu

- **Default** (all values): 0.0%
- Select **Reset All** to set all values back to their default settings.

### Hue/Saturation Color Balance Menu

If the current input's type is set to **Composite**, **S-video**, **YPbPr**, or **SDI**, the **Hue/Saturation Color Balance Menu** appears:



Figure 4-11. Hue/Saturation Color Balance Menu (sample)

Please note:

- **Hue** is measured in degrees, and is [N/A] for YP<sub>b</sub>P<sub>r</sub> inputs.
  - ~ **Adjustment range**: -90 to +90
- **Saturation** is measured in percentage.
  - ~ **Adjustment range** (Composite, S-Video): 0% to 150% (100% nominal)
  - ~ **Adjustment range** (SDI, YP<sub>b</sub>P<sub>r</sub>): 75.0% to 125.0%
- Select **Reset All** to set all values back to their default settings.

### Timing Adjust

From the **Input Menu**, select **Timing Adjust** to display the **Timing Adjust Menu**. The menu changes *slightly*, depending on the selected sampling mode (1:1 or Oversample). This menu allows for exact positioning of the input signal's active area.

The figure below illustrates the **Timing Adjust Menu**:

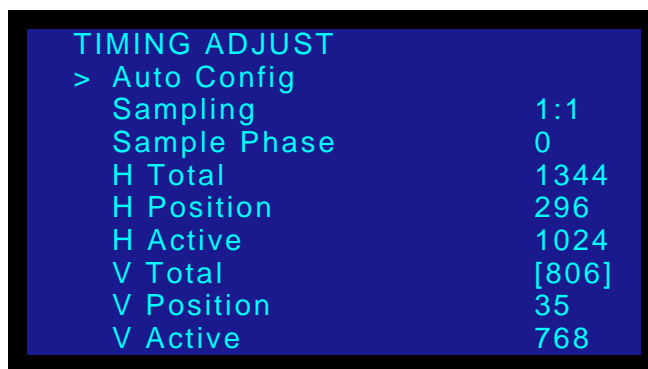

Figure 4-12. Timing Adjust Menu (sample)

The following functions are available:

- **Auto Config** — This function is identical to the **Auto Config** function located in the **Image Adjust Menu**.



## 4. Operation

### Using the Main Menu

Select **Auto Config** to perform an automatic input configuration on the selected source.

#### Note

In this mode, for the selected image, the system finds the first and last pixel on each edge, and ensures (to the best possible extent) that the entire image is visible. In addition, if the input is analog, the system automatically phases the input to determine the correct sampling phase.

#### Tip

Ensure that there are non-black pixels around the extreme edges of your active video, in order for the image to be properly sized by the **Auto Config** function. For example, if you use a Windows desktop with a high luminance background, the **Auto Config** function will be accurate. If, on the other hand, you use a desktop image with a black border, the image will not be properly sized.

- **Sampling** — select this function to change the sampling for the selected input. Available values are: **Oversample** and **1:1** (default). Please note:
  - ~ When **1:1 Sampling** is selected, the system provides pixel-for-pixel sampling, and generally better image quality.
  - ~ When **Oversample** is selected, the system performs multiple samples for every pixel, with a resulting “softer” image.
  - ~ **Oversample** is only available for RGB and YP<sub>b</sub>P<sub>r</sub> analog inputs.
  - ~ All other input types have defined sample clocks that are inherently **1:1**. If the input is set to one of the other types, the value is **[1:1]**.
- **Sample Phase** — This selection is only available when **Sample Mode** is **1:1** and the input is analog RGB or YP<sub>b</sub>P<sub>r</sub>. If **Oversample** is selected, the field is hidden. The sample phase value is initially filled in by the **Auto Config** command, or set to the default value. You can further fine-tune the image by adjusting the sample clock phase directly.
  - ~ **Adjustment range:** -16 to 15
  - ~ **Default:** 0

For all **Horizontal** “active area” fields, all units are measured in pixels:

- **H Total** — adjusts the total pixel count per line. This value cannot be adjusted if the input type is **DVI / SDI**.
- **H Position** — adjusts the offset of start of active area from H sync.
- **H Active** — sets the size of the active area.

For all **Vertical** “active area” fields, all unit are measured in lines.

- **V Total** — indicates the total line count per frame. This value is measured, and can never be adjusted. Its value will always be shown in brackets.
- **V Position** — sets the offset of start of active area from V sync.
- **V Active** — sets the size of the active area.

## 4. Operation

Using the Main Menu

### Processing

From the **Input Menu**, select **Processing** to display the **Processing Menu**:



Figure 4-13. Processing Menu (sample)

The following functions are available:

- **Sync Selection** — This function applies only to **Analog RGB** inputs. The digital input sources have embedded syncs, and the composite, S-video, and YP<sub>b</sub>P<sub>r</sub> inputs always take sync from the Y (or composite) channel. For these digital inputs, the value field indicates **[N/A]**.  
The sync choices are **Auto**, **H/V** (horizontal/vertical sync), **CSync** (composite sync) and **SOG** (sync on green).
  - ~ In **Auto** mode, the system finds sync in any of the three possible sources.
    - If one of the sources is chosen, the system uses only that input as a sync source.
    - If the system does not find sync at that source, it acts as if it is in **Auto** mode.
  - ~ The default selection for Analog RGB inputs is **Auto**.
- **Pulldown Compensation** — This function only applies to standard video (component, s-video, composite and SD/HD SDI) inputs. The mode, which detects the 3:2 film pulldown sequence, should be turned **ON** to properly process video derived from film source material.
  - ~ **Adjustment range:** OFF, ON
  - ~ **Default:** OFF
- **Sync Slice** — This function selects the sync comparator threshold for RGsB (RGB with Sync on Green) or YP<sub>b</sub>P<sub>r</sub> analog component video sources. When ACS-2048 detects Macrovision copy protection on the incoming YP<sub>b</sub>P<sub>r</sub> NTSC/PAL video, the **Sync Slice** value is automatically repositioned to 60mV to account for the reduced amplitude sync pulse.
  - ~ **Adjustment range:** 20mV to 280mV, adjustable in steps of 10mV
  - ~ **Default:** 160mV

### Reset Config

From the **Input Menu**, select **Reset Config** to remove all user-entered configuration settings from the current input, and restore the input's format parameters from the system's internal library values. When you select the function, you will be prompted to reset (**SEL**) or continue without resetting (**ESC**).

Note that if the current format was derived as a best guess, those “guess” values are restored.

## Save Input Config

From the **Input Menu**, select **Save Config** to save an input configuration for the selected input in a user-defined file. The **Save Config Menu** appears:



Figure 4-14. Save Config Menu (sample)

The ACS-2048 provides a global pool of 64 input configuration files, and the default file number is a 1:1 association with the input number itself (e.g., input 1 = 1, input 2 = 2, etc.). Users can define one (or more) input configuration files as required.

- To change the file number, scroll to the **File Number** line. Press **SEL**, and select a file number from 1 - 64.
- To save the file, scroll to the **Save File** line and press **SEL**. After saving, the system remains on the menu, enabling you to save additional files.

Please note the following important points regarding input configuration files:

- The ACS-2048 supports multiple input configuration files for each physical input. When you select a file number and save an input, the system automatically creates a file association on the **File Association Menu**, using the selected file number. Refer to the "[File Association](#)" section on page 64 for details.
- When you perform the **Save Config** function, input configuration parameters are saved in non-volatile memory for each input source. If you *do not* perform the **Save Config** function, data for the selected input will not be restored the next time you access that input via the **Input Menu**, nor will they be restored upon the next system power up sequence.
- If you make a change within the **Input Menu**, and attempt to exit the menu (by pressing **ESC**, **TEST PAT**, or by selecting another input) *without* saving changes, the system displays the following prompt:

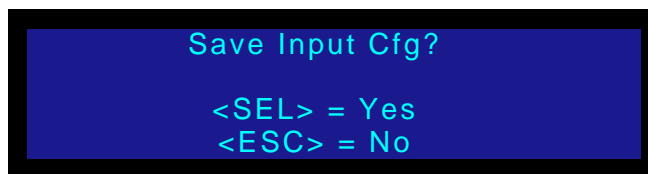

Figure 4-15. Save Input Configuration Prompt

- ~ Select **Yes (SEL)** to save changes. The system switches to the **Save Config Menu**, where you can use the current file number, or select a different one.
- ~ Select **No (ESC)** to continue operation without saving the changes.

## 4. Operation

### Using the Main Menu

#### Delete Config

From the **Input Menu**, select **Delete Config** to delete a saved input configuration file. The **Delete Config Menu** appears:



Figure 4-16. Delete Config Menu (sample)

- To delete a saved input configuration file, scroll to the **File Number** line. Press **SEL** and select a file number. Note that only saved files will be displayed as you rotate the **ADJUST** knob.
- To delete the selected file, scroll to the **Delete File** line and press **SEL**. After deleting, the system remains on the menu, enabling you to delete additional files.

#### Recall Config

From the **Input Menu**, select **Recall Config** to recall an input configuration file for the selected input. This file will be used when that input is selected on the front panel.

The **Recall Config Menu** appears:



Figure 4-17. Recall Config Menu (sample)

- To recall a saved input configuration file, scroll to the **File Number** line. Press **SEL**, and select a file number.
- To recall the selected file, scroll to the **Recall File** line and press **SEL**. After recalling, the system remains on the menu, enabling you to recall additional files.

Please note:

- The ACS-2048 supports multiple input configuration files for each physical input. When you select a file number and recall an input, the system automatically creates a file association on the **File Association Menu**, using the selected file number. Refer to the [“File Association”](#) section on page 64 for details.

## Output Menu

From the **Main Menu**, select **Output** to display the **Output Menu**, which enables you to configure the outputs of the ACS-2048.



Figure 4-18. Output Menu (sample)

Following are descriptions of each **Output Menu** function:

- [Output Format](#)
- [Output Mode](#)
- [Gamma](#)
- [Test Pattern](#)
- [Output Adjust](#)
- [Save Output Config](#)

### Output Format

From the **Output Menu**, select the top **Output Format** line to view or change the current output format. This line indicates the format in the following form:

**Hact x Vact @ Vr Hz**

Two output formats can be set for the ACS-2048:

- 2048x1080p @ 59.94Hz
- 2048x1080p @ 50Hz

**Note**

The output format is not updated until **SEL** is pressed.

### Output Mode

From the **Output Menu**, select **Output Mode** to change the selected output mode between 8-bit, 10-bit or 12-bit output.

- **Adjustment range:** 8-bit, 10-bit or 12-bit output
- **Default:** 10-bit (this mode requires connecting both outputs to the projector)

Please note the following points regarding the ACS-2048's two DVI-I output connectors:

- In 10-bit or 12-bit mode, both outputs (A and B) must be connected to the projector. In 8-bit mode, a connection is required from Connector A only.
- **Connector A:** Only 8-bit output mode can be selected on this connector, providing standard 8-bit DVI output.

## 4. Operation

### Using the Main Menu

- **Connector B:** To increase color depth, 10-bit or 12-bit output mode can be selected on this connector.

### Gamma

From the **Output Menu**, select **Gamma** to specify the Gamma associated with the current output.

- **Adjustment range:** 1.0 to 3.0, in steps of 0.1
- **Default:** 1.0

### Test Pattern

From the **Output Menu**, select **Test Pattern** to display the **Test Patterns Menu**:



Figure 4-19. Test Patterns Menu (sample)

#### Note

If the **Menu Context** mode is **ON** in the **User Preference Menu**, the **Test Patterns Menu** appears whenever the **TEST PAT** button is pressed, allowing you to select an internal test pattern and adjust additional test pattern parameters.

The following functions are available:

- **Mode** — This function enables or disables the test pattern generator.
  - ~ When the mode is turned **ON**, the **TEST PAT** button lights, and the currently selected input drops to its backlit state (depending on sync).
  - ~ When the mode is turned **OFF**, the **TEST PAT** button turns off, and the last selected input will either be lit bright or blinking (depending on sync). The **Test Pattern Menu** remains on the display.

#### Note

Within this menu, the **TEST PAT** button to turn off the mode, the system returns to the **Main Menu**. Refer to the "[Using Test Patterns](#)" section on page 71 for details.

- **Type** — This function enables you to select a test pattern. Available choices are:
  - ~ Off
  - ~ H Ramp
  - ~ V Ramp
  - ~ 100% Col Bars
  - ~ 16 x 16 Grid
  - ~ 32 x 32 Grid
  - ~ Burst

- ~ 75% Col bars
- ~ 50% Gray
- ~ Gray Steps 1
- ~ Gray Steps 2
- **Raster Box** — This function enables or disables the raster box.
  - ~ When turned **ON**, the system displays a one-pixel border around the active output area. Note that the raster box includes gaps that enable you to precisely align the input video to fill the output raster.
  - ~ When turned **OFF**, the output is clean, without the border.

### Output Adjust

From the **Output Menu**, select **Output Adjust** to scale the entire output to fit the theatre's physical setup (e.g., curtains, drapes, and off-axis projection).

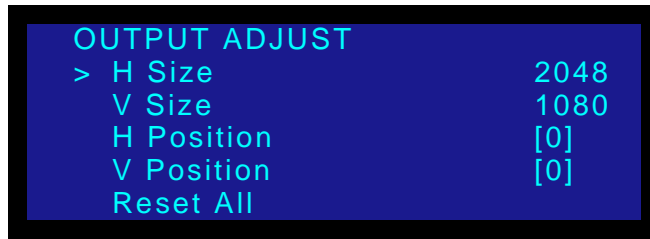

Figure 4-20. Output Adjust Menu (sample)

This adjustment must be performed while you view the projector's output on your screen. When you enter this menu, a solid white raster box appears at the size and position specified within the menu. The selected input is temporarily turned off, and the output video is black. As you adjust H and V size and position, the raster box adjusts accordingly. When you exit the menu, the raster box is cleared, and the selected input will be scaled to fit within this exact size and position.

The following functions are available:

- **H Size** — adjusts the horizontal size in pixels.
- **V Size** — adjusts the vertical size in lines.
- **H Position** — this field is bracketed when **H Size** is 2048. When you adjust **H Size** below 2048, this field becomes active, enabling you to adjust horizontal position in pixels. Positioning is limited to the overall 2048 "space," and the image cannot be moved off screen.
- **V Position** — this field is bracketed when **V Size** is 1080. When you adjust **V Size** below 1080, this field becomes active, enabling you to adjust vertical position in lines. Positioning is limited to the overall 1080 "space," and the image cannot be moved off screen.
- **Reset All** — resets H and V Size to 2048 x 1080, and H and V Position to [0].

## 4. Operation

Using the Main Menu

### Save Output Config

From the **Output Menu**, select **Save Config** to save the current output configuration. A message is briefly shown, after which the system returns to the **Output Menu**.



Figure 4-21. Saving Output Configuration Message

Please note the following important points regarding the output configuration file:

- When you perform the **Save Config** function, all configuration parameters from the **Output Menu** are saved in non-volatile memory. If you *do not* perform the function, output data will not be restored upon the next system power up.
- If you make a change in the **Output Menu**, and attempt to exit the menu (by pressing **ESC** or **TEST PAT**) *without* saving changes, the system displays the following prompt:

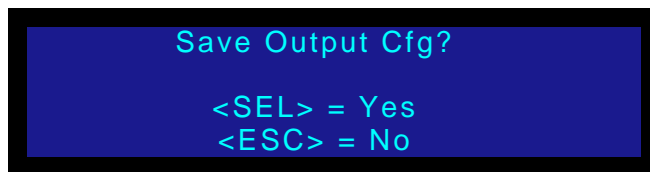

Figure 4-22. Save Output Configuration Prompt

- ~ Select **Yes (SEL)** to save changes.
- ~ Select **No (ESC)** to continue operation without saving the changes.



## System Menu

From the **Main Menu**, select **System** to display the **System Menu**, which enables you to adjust transition times, VFD Brightness, and other “system” related functions:

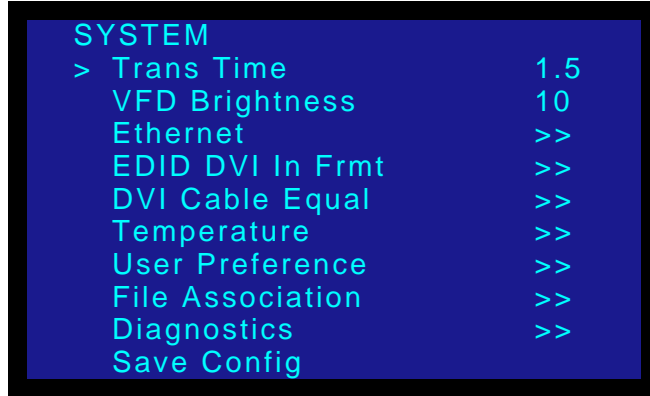

Figure 4-23. System Menu (sample)

Following are descriptions of each **System Menu** function:

- [Trans Time](#)
- [VFD Brightness](#)
- [Ethernet](#)
- [EDID DVI Input Format](#)
- [DVI Cable Equalization](#)
- [Temperature](#)
- [User Preference](#)
- [File Association](#)
- [Diagnostics](#)
- [Save System Config](#)

### Trans Time

From the **System Menu**, select **Trans Time** to change the current transition rate that is used when you switch between inputs. Please note the following points:

- The transition type is fixed as "**Transition to Black.**" When you change inputs, the current input fades to black, then the new input's video transitions up at the selected **Trans Time**.
- The transition time is defined as the total time required for the system to fade to black, switch to the new input, and fade up to the new input.

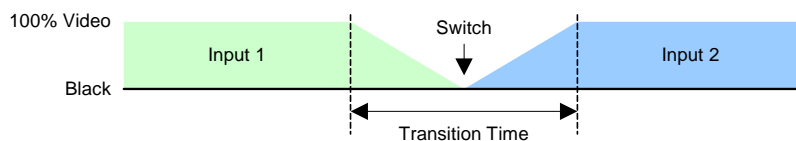

Figure 4-24. Transition Time Diagram

## 4. Operation

### Using the Main Menu

Note that transition times are specified for switching applications with **Auto Acquire** turned **OFF**. When **Auto Acquire** is **ON**, the transition time is greater, due to the additional time required to analyze the input video timing.

Transition values are listed below:

- **Adjustment range:** 1.5 - 5.0 seconds
- **Default:** 2.0 seconds

### VFD Brightness

From the **System Menu**, select **VFD Brightness** to control the intensity of the front panel VFD (vacuum fluorescent display).

- **Adjustment range:** 1 - 15 (1 is the dimmest setting)
- **Default:** 10

#### Note

It is recommend that you use a low intensity setting to avoid "burn-in" of the display.

### Ethernet

From the **System Menu**, select **Ethernet** to display the **Ethernet Menu**:



Figure 4-25. Ethernet Menu (sample)

The following Ethernet functions are available:

- **DHCP** — DHCP can be turned **OFF** or **ON**.
  - ~ When **OFF**, the **Config Network** field appears, which enables you to manually enter a static IP address, Subnet mask and Gateway.

#### Note

Always consult with your network administrator to obtain valid IP, subnet mask and gateway addresses.

- ~ When **ON**, the ACS-2048 queries the DHCP server for a valid IP address, and the **Config Network** field is hidden.
  - If the ACS-2048 finds a DHCP server and receives an IP address, the address is displayed.
  - If a server is not found, an IP address is not assigned.

## 4. Operation

### Using the Main Menu

- **Config Network** — select this function to display the **Config Network Menu**, which enables you to choose the specific Ethernet address you wish to change.



Figure 4-26. Config Network Menu

- ~ Select **Set Static IP** to display the **Static IP Menu**, which enables you to set a static IP address when a DHCP server is not available. The editing procedure is discussed below.



Figure 4-27. Static IP Menu

- ~ Select **Set Netmask** to display the **Netmask Menu**, which enables you to set a netmask. The editing procedure is discussed below.

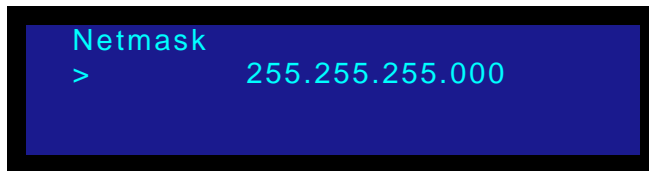

Figure 4-28. Netmask Menu

- ~ Select **Set Gateway** to display the **Gateway Menu**, which enables you to set a gateway. The editing procedure is discussed below.

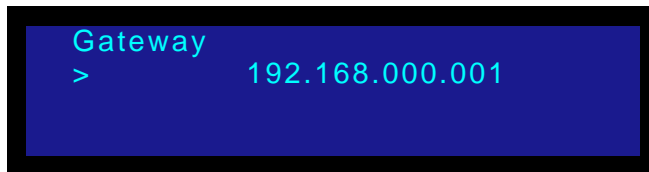

Figure 4-29. Gateway Menu (sample)

Use the following steps to edit the IP address, Netmask or Gateway. Valid fields range from 000 to 255.

- Press **SEL** to begin editing. This action highlights the first digit, and displays the carat “^.”
- Use the **ADJUST** knob to move the carat left and right through the address.

## 4. Operation

### Using the Main Menu

- c. When the desired digit is highlighted, press **SEL** to edit the value. The carat changes to the pound sign "#."
- d. Use the **ADJUST** knob to select the desired value (0 - 9).
- e. Once the value is selected, press **SEL** to "accept" the new value. The pound sign "#" changes back to the carat "^."
- f. Repeat the process from step **b** for all additional digits that you wish to change.
- g. When all editing is complete, press **ESC** to display the **Apply Changes Menu**.
  - Select **Yes (SEL)** to apply all changes.
  - Select **No (ESC)** to exit the procedure without saving changes.

In each case, system returns to the root menu (Static IP, Gateway, or Netmask).

When Ethernet setup is complete, you can communicate with the ACS-2048 via the Ethernet. Refer to the "[Remote Commands](#)" section on page 98 for details.

- **IP Address** — The **IP** line is an information-only line that shows the current IP address in all modes (with DHCP on or off). If an IP address has not been established (no DHCP server found, or the network cable is not connected), the address reads "000.000.000.000."

#### Note

The ACS-2048's default IP address is **192.168.000.5**.

- **MAC Address** — The **M** line is an information-only line that shows the MAC (hardware) address of the unit's Ethernet port.

### EDID DVI Input Format

From the **System Menu**, select **EDID DVI In Frmt** to display the **EDID DVI Input Format Menu**, which enables you to update the preferred EDID resolution for the ACS-2048's two DVI inputs (**2** and **3**).



Figure 4-30. EDID DVI Input Format Menu (sample)

#### Important

This menu is designed for advanced users only. Do not reprogram EDID unless it is necessary.

EDID (Extended Display Identification Data) is a VESA standard data format that contains information about a display device and its capabilities, including the preferred (as well as the allowed) device resolutions.

The ACS-2048's EDID file is stored in non-volatile memory. This file is read by a computer's DVI graphics card during boot-up, when its DVI output is connected to a DVI-I input connector on the ACS-2048 system (inputs **2** and **3**). The ACS-2048 must be powered on first for the EDID information to be read.

The following functions are available:

- **Input** — selects the exact inputs that you wish to program: **ALL** (inputs 2 and 3), **2** (individually), or **3** (individually).
- **EDID Format** — This line displays the system's current EDID format, and enables you to select a new EDID format to program into non-volatile memory. As required, press **SEL** to scroll through the formats.
- **Program EDID** — Select this function to program the preferred DVI resolution, as defined on the **EDID Format** line. When **SEL** is pressed, the following message is briefly displayed.

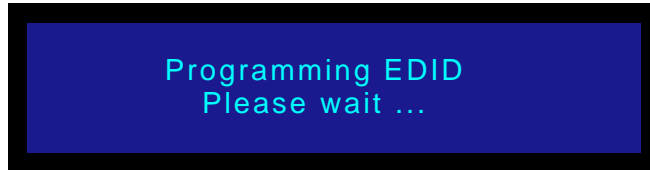

**Figure 4-31.** Programming EDID Message 1

If the non-volatile memory programming is successful, the following message is displayed:

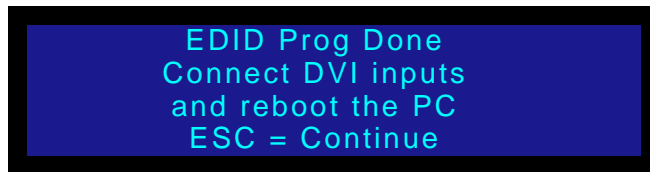
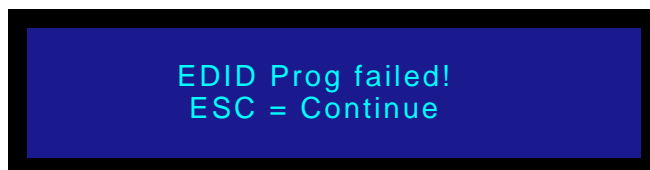

**Figure 4-32.** Programming EDID Message 2

**Note**

At this point, reboot the external computer(s) in order for the new EDID information to be read, and the new preferred resolution to become available.

If the EDID programming failed, the following message will be displayed:



**Figure 4-33.** EDID Programming Failed Message

If this message persists, please contact customer service for technical support.

## 4. Operation

Using the Main Menu

### DVI Cable Equalization

From the **System Menu**, select **DVI Cable Equal** to display the **DVI Cable Equalizer Menu**, which enables you to adjust input cable equalization parameters for both DVI inputs simultaneously, or individually for inputs **2** or **3**.

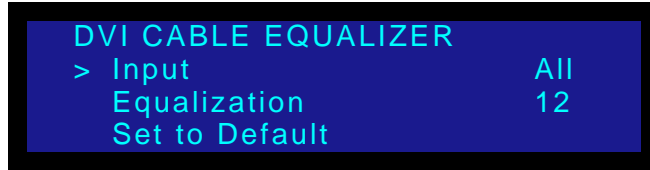

Figure 4-34. DVI Cable Equalizer Menu (sample)

The following functions are available:

- **Input** — selects the exact inputs that you wish to set: **ALL** (inputs 2 and 3), **2** (individually), or **3** (individually).
- **Equalization** — The equalization adjustment range is from **0** (short cable equalization) to **15** (long cable equalization). The default value is **12**, which indicates “moderate” equalization.

In general, the default should be adequate for most users, unless cables longer than 5M are used, and unless your signals are running at high pixel clock rates (e.g., UXGA).

- **Set to Default** — returns the equalization settings to their default values.

#### Note

Equalization is a subjective “visual” adjustment, which depends on three important factors: cable length, signal quality and cable quality. If you adjust the equalization, optimize the setting for the lowest amount of visual artifacts.

### Temperature

From the **System Menu**, select **Temperature** to display the **System Temperature Menu**.

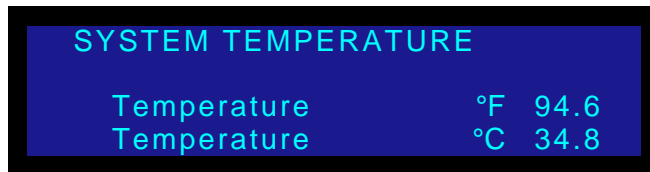

Figure 4-35. System Temperature Menu (sample)

The **System Temperature Menu** is an information-only display that indicates the chassis’ internal temperature in both celsius and fahrenheit. When the menu is displayed, temperature values update every 4 seconds.

Note that the ACS-2048 measures the internal temperature for an “over-temp” condition every 5 minutes. If the system’s internal temperature exceeds 122° F (50° C), the following message appears:

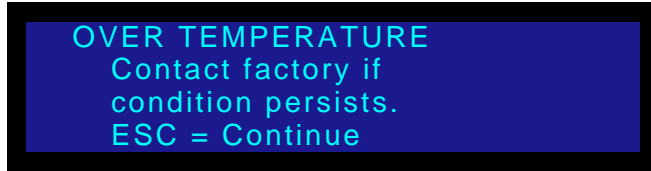

Figure 4-36. Over Temperature Warning

To clear the message and continue operations, press **ESC**.

**Note**

This message is a warning only, which does not prevent the operation of the ACS-2048. If this message appears, it is recommended that you contact Barco Customer Service.

### User Preference

From the **System Menu**, select **User Preference** to display the **User Preference Menu**:



Figure 4-37. User Preference Menu (sample)

The following functions are available:

- **Auto Input Save** — When enabled, the system automatically saves the selected input after it has been acquired for the first time. The field has no effect if the **Auto Acquire** mode is **OFF**.
- **All Inputs Sel** — This preference tells the system to allow (or disallow) the selection of inputs that do not have a valid sync signal detected.
  - ~ When **ON**, you can select inputs that do not have valid sync (and are not backlit).
  - ~ When **OFF**, you cannot select inputs that do not have valid sync, and the “**Invalid Selection**” message will be displayed if you attempt to do so.
- **Menu Context** — This preference determines the behavior of certain ACS-2048 menus. The following conditions apply:
  - ~ When **Menu Context** is **ON**, regardless of the menu currently being displayed, menus automatically change their context when an **Input** or the **TEST PAT** button is pressed.
    - ▲ **Example:** The **Status Menu** is currently displayed. When you select a different input, the **Input Menu** is immediately displayed for that input.

## 4. Operation

### Using the Main Menu

- ▲ **Example:** The **Status Menu** is currently displayed. When you press **TEST PAT**, the **Test Patterns Menu** is immediately displayed.
- ~ When **Menu Context** is **OFF**, menu context does not change when an **Input** or the **TEST PAT** button is pressed.

### File Association

From the **System Menu**, select **File Association** to display the **File Association Menu**:

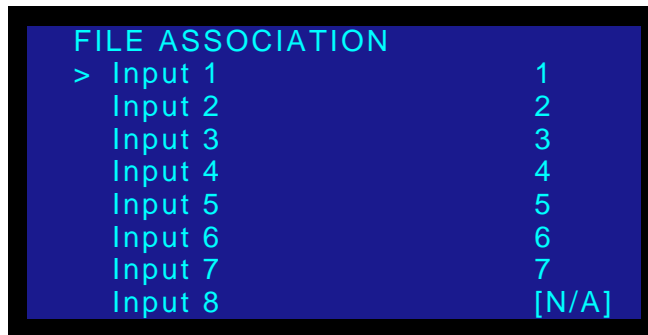

Figure 4-38. File Association Menu (sample)

The **File Association Menu** enables you to associate an input configuration file with each of the eight inputs. The “associations” listed on the menu tell the system which file to use when an input is selected from the front panel. Please note:

- By default (and after a system reset), file associations are 1:1 with the input numbers themselves (e.g., input 1 = 1, input 2 = 2, etc.). However, any association can be configured.
- On the **Save Config** and **Recall Config** menus, when you select a file number and save or recall an input, the system automatically creates a file association, using the selected file number. For example, if you save input 1 with file number 10, that association will be listed on the **File Association Menu**.

To create a file association:

- Scroll to the desired input line and press **SEL**.
- Use the **ADJUST** knob to choose the desired file, and press **SEL** to accept. This file will now be used “first” when that input is selected from the front panel — whether or not **In Auto Acquire** is **ON**.
- Repeat to configure additional file associations.

Refer to the “[Understanding Auto Acquire](#)” section on page 70 for additional information on the **Auto Acquire** mode.



## Diagnostics

From the **System Menu**, select **Diagnostics** to display the **Diagnostics Menu**:

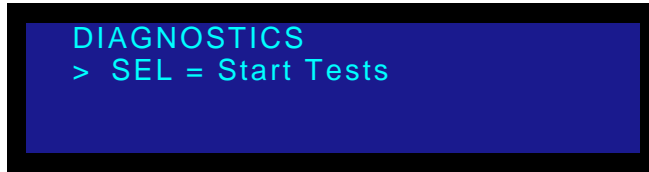

Figure 4-39. Diagnostics Menu

If you suspect a problem with the ACS-2048, press **SEL** to run a series of internal diagnostic tests. The menu will report back "**PASS**" or "**FAIL**."

### Note

If the menu report "**FAIL**," please contact Barco Customer Service. They will assist you with troubleshooting.

## Save System Config

From the **System Menu**, select **Save Config** to save all current "system" settings so that they may be restored at power up. A message is briefly shown, after which the ACS-2048 returns to the **System Menu**.

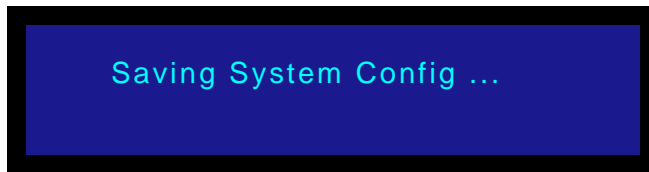

Figure 4-40. Saving System Configuration Message

Please note the following important points regarding the system configuration file:

- When you perform the **Save Config** function, all configuration parameters from the **System Menu** are saved in non-volatile memory. If you *do not* perform the function, data will not be restored upon the next system power up sequence.
- This command also saves the currently selected **input** channel as the default selection upon power up.

### Note

If you want the ACS-2048 to always power up and acquire an input other than input 1, perform the **Save System State** command while the desired input is selected.

- If you *do not* perform the **Save System State** function, data will not be restored upon the next system power up sequence.

## 4. Operation

### Using the Main Menu

- If you make a change in the **System Menu**, and attempt to exit the menu (by pressing **ESC**, **TEST PAT**, or by selecting another input) *without* saving changes, the system displays the following prompt:

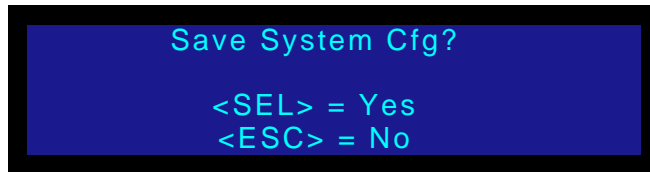

**Figure 4-41.** Save System Configuration Prompt

- ~ Select **Yes (SEL)** to save changes.
- ~ Select **No (ESC)** to continue operation without saving the changes.

## Status Menu

From the **Main Menu**, select **Status** to display the **Status Menu**:

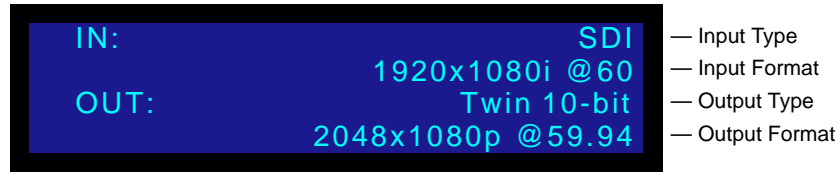

Figure 4-42. Status Menu (sample)

The **Status Menu** provides information about the currently selected system input and output. The input section always reflects the selected input channel, as determined by the input buttons. Please note:

- If **Menu Context** is **ON** (on the **User Preference Menu**), selecting a different automatically displays the **Input Menu**. The **Status Menu** will be updated with new data the next time you access it.
- If **Menu Context** is **OFF**, the **Status Menu** remains on display when you select a different input, and it automatically updates with the input's new status. Press **ESC** to return to the **Main Menu**.

In the **Status Menu**, the variable fields are as follows:

- **Input Type** — Specifies the type of input signal being processed.
- **Input Format** — Indicates the current input video format in the form:

**Hact x Vact @ Vr Hz**

▲ 1280x1024@60 Hz

If the currently selected input does not have a valid input signal, the **Input Format** field displays "**Invalid Signal**."

- **Output Type** — indicates the selected output type, as well as HDCP status. The following labels can appear, depending on the output and HDCP implementation:
 

~ 8-bit	~ Twin 12-bit
~ 8-bit HDCP	~ Twin 12-bit HDCP
~ Twin 10-bit	~ HDCP Violation
~ Twin 10-bit HDCP	

### Important

If the label "**HDCP Violation**" appears, it indicates that an HDCP source is selected, but a non-HDCP compliant monitor or device (such as an HDCP repeater) has been detected. In this situation, video output is disabled.

- **Output Format** — Indicates the current output video format in the form:

**Hact x Vact @ Vr Hz**

▲ 2048x1080@59.94 Hz

## 4. Operation

Using the Main Menu

### Software Version

From the **Main Menu**, select **Software Version** to display the **Software Version Menu**:



Figure 4-43. Software Version Menu

The version shown is the current version of installed operating firmware. This number changes when you update system software. In Chapter 5, refer to the “[Software Upgrade Overview](#)” section on page 74 for software update instructions.

### Factory Reset

From the **Main Menu**, select **Factory Reset** to display the **Factory Reset Menu**:

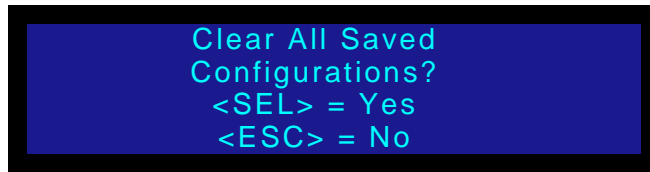

Figure 4-44. Factory Reset Menu

This function enables you to reset the ACS-2048 to its factory default condition, in which all input, output and system configuration files are deleted. When the command is executed, a confirmation menu is shown.

- Press **SEL** to reset the system.
- Press **ESC** to cancel the operation, and return to the **Main Menu**.

The following attributes constitute a “factory default” condition:

- The **TEST PAT** button is selected.
- All “Sync Present” states are shown correctly (backlit buttons).
- The **Output** is set to 2048x1080@59.94.
- The **Output Raster Box** is **OFF**.
- The **Main Menu** is displayed.
- All menu items are set to their default values (as specified throughout this chapter).
- All file associations are returned to 1:1.

---

## Using Inputs

This section provides background information and instructions for using inputs. The following topics are discussed:

- [Understanding Backlighting](#)
- [Input Selection Rules](#)
- [Understanding Auto Acquire](#)

### Understanding Backlighting

The backlighting of the input buttons reflects sync detection, as follows:

- **Off** — indicates that sync has not been detected on the input connector, and the input cannot be used on air. The input is **invalid**.
- **Dim Yellow** — (or backlight on) indicates that sync has been detected, and the source is available (valid) for use on air. The input is **valid**.
- **Bright Yellow** — indicates the currently selected “on air” source.
- **Blinking** — indicates that sync has been lost from the current “on air” source. In this situation, internal “black” will automatically replace the previous on air source, and the source cannot be used on air until sync is restored.

### Input Selection Rules

Please note the following important rules regarding input selection:

- Each input that you select will be routed to the output, using the current transition rate (as entered on the **System Menu**).
- When you press a button for a valid input (sync is detected and the button is backlit), the ACS-2048 immediately transitions to the selected input.
  - ~ If **Menu Context** is **ON** (in the **User Preference Menu**), the **Input Menu** appears.
  - ~ If **Menu Context** is **OFF**, the current menu remains.
- If you press an unlit input button (sync is not detected), the following message appears:

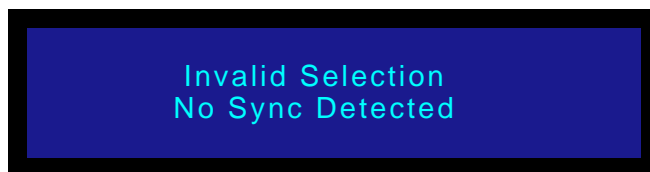

Figure 4-45. Error message: No Sync Detected

## 4. Operation

### Using Inputs

- **Input 8** is currently not implemented. If the input button is pressed, the following message appears:



Figure 4-46. Error message: Invalid Selection

- Remember that the **Menu Context** option on the **User Preference Menu** affects the way that menus are displayed. Refer to the "[User Preference](#)" section on page 63 for details.

## Understanding Auto Acquire

Please note the following important points regarding the **Auto Acquire** mode:

- If **In Auto Acquire** is **ON** and a valid input is selected that does *not* have a saved input configuration file associated with it, the system attempts to acquire the source, save an input configuration file, and smoothly transition to the new source.

### Note

The input configuration file will only be saved if the "**Auto Input Save**" mode is **ON** in the **User Preference Menu**.

Two different error messages can be displayed when **In Auto Acquire** is **ON**:

- ~ **Mismatch**: The ACS-2048 cannot match to any saved input configuration, or to any format in the input format table.
  - ~ **Invalid Signal**: No valid input signal is detected.
- If **In Auto Acquire** is **OFF** and a valid input is selected with a saved input configuration file, the system compares the library file to the input's timing.
    - ~ If the timings match, the system transitions to the input.
    - ~ If the timings do not match, the system displays black and the "**Invalid Signal**" message appears.

Three error messages can be displayed when **In Auto Acquire** is **OFF**:

- ~ **Mismatch**: The ACS-2048 cannot match to any saved input configuration, or to any format in the input format table.
  - ~ **Invalid Signal**: No valid input signal is detected. In this situation, the video output will be black.
  - ~ **No Saved File**: A configuration file has not been saved for the input.
- When a new (unsaved) input is selected, the system performs one of three "auto acquire" sequences, depending on the current system condition:
    - ~ **Condition 1**: No source is currently selected, and the output is black. This condition occurs after a factory reset.
      - When you select a new source, the system transitions to the source — once the "auto acquire" is complete.

- ~ **Condition 2:** A source is currently showing on the output.
  - When you select a new source, the system transitions to black. Once the “auto acquire” of the new source is complete, the system transitions to the source.
- ~ **Condition 3:** A test pattern is showing on the output.
  - When you select a new source, the system transitions the test pattern off, and then follows the rules outlined for conditions 1 or 2 — depending on the current situation.

---

## Using Test Patterns



Pressing the **TEST PAT** button selects the internal test pattern as the ACS-2048's source. There are two ways to use the button:

- When **TEST PAT** is pressed, the button lights, and the internal test pattern is routed to the output. When you select another input, the system transitions to the new input.
- When the **TEST PAT** button is already lit, press the **TEST PAT** button again to toggle back to the last selected input.

### Note

If the **Menu Context** mode is **ON** in the **User Preference Menu**, the **Test Patterns Menu** appears whenever the **TEST PAT** button is pressed, allowing you to select an internal test pattern and adjust additional test pattern parameters.

Please note the following important points regarding test pattern usage:

- When **Menu Context** is **ON** and **TEST PAT** is pressed, the last selected test pattern is automatically enabled, and the **Type** field is selected, enabling you to change patterns easily.
- If you need to change the state of the Raster Box in this mode, press **ESC**, scroll to the **Raster Box** field, and change the function as required.
- Regardless of the **Menu Context** mode, pressing **TEST PAT** has no effect on the state of the Raster Box. It always remains in its last selected mode.

## 4. Operation

### Front Panel Lockout

---

## Front Panel Lockout

The ACS-2048 includes a front panel lockout mode which when enabled, locks out the front panel from all source selections, including the Test Pattern.

- Use the following steps to lock (and unlock) the front panel:
  1. Press and hold the **SEL** and **ESC** buttons for 3 seconds. Once this button combination has been detected, the following display appears:

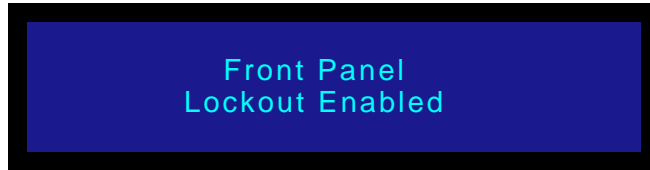

**Figure 4-47.** System message: Lockout Enabled

In the "lockout" mode:

- ~ All button pushes and all turns of the rotary knobs will be ignored.
  - ~ All Ethernet communications and commands will function normally.
  - ~ All button lights will continue to reflect the proper state of the inputs.
2. To disable the front panel lockout mode, press and hold the **SEL** and **ESC** buttons for 3 seconds. Once detected, the system returns to the previous menu that was shown before the "lockout" mode was enabled.



# 5. Upgrading Software

---

## In This Chapter

This chapter provides detailed instructions for upgrading ACS-2048 system software. The following topics are discussed:

- [Software Upgrade Overview](#)
- [Hardware Requirements](#)
- [Software Requirements](#)
- [Downloading Software](#)
- [Ethernet Upgrade Method](#)

## 5. Upgrading Software

### Software Upgrade Overview

---

## Software Upgrade Overview

Firmware files for the ACS-2048 are loaded into the hardware at power-up. These files are stored in the unit's onboard flash memory.

The ACS-2048's system software can be easily upgraded using the following steps:

- Downloading the appropriate "upgrade" file from the Barco FTP site or website
- Connecting a PC (or laptop) to the ACS-2048
- Launching a web browser
- Connecting to the ACS-2048 using its IP address
- Following the upgrade instructions in the browser

---

## Hardware Requirements

The following hardware items are required for upgrading ACS-2048 software:

- IBM compatible computer with an available Ethernet port.
- Local Ethernet network, including an Ethernet switch

---

## Software Requirements

The following list outlines software requirements for upgrading ACS-2048 software:

- Ensure that your PC (or laptop) uses the Windows<sup>®</sup> 2000 or XP operating systems.
- Ensure that your PC (or laptop) has a web browser installed, such as Windows Internet Explorer<sup>®</sup> or Mozilla Firefox<sup>®</sup>.

Software files can be downloaded from either the Barco Folsom FTP site or the Barco website, as described in the following ["Downloading Software"](#) section.

---

## Downloading Software

Two different methods can be used to download ACS-2048 software:

- [Via FTP Site](#)
- [Via Web Site](#)

### Via FTP Site

Barco Folsom's FTP site address is: <ftp.folsom.com>

■ To download software from the FTP site:

1. Create a target folder on your PC (e.g., ACS-2048).
2. Ensure that your PC is connected to the internet.
3. There are three ways to log on to the FTP site:
  - a. If you are using an FTP client such as **Ipswitch WS\_FTP Professional**, logon to our site as follows:
    - **FTP Site:** ftp.folsom.com
    - **User name:** anonymous
    - **Password:** your email address
  - ▲ **Example:** johndoe@somecompany.com
  - b. If you are using a web browser, point the browser to:  
**ftp://ftp.folsom.com**

#### Note

If you are using **Internet Explorer 7**, after entering the FTP address, click **Page**, and then click **Open FTP Site in Windows Explorer**.

- c. To use Windows Explorer, right-click the **Start** button, then click **Explore**. When the Explorer window opens, enter the FTP site in the address bar.
4. Once logged on, navigate to the following directory:  
**ftp://ftp.folsom.com/Image Processing/ACS-2048/**
  5. Transfer the following file to the target folder on your PC:  
**ACS2048\_##\_##.tar.gz**
  6. Please continue with the "[Ethernet Upgrade Method](#)" section on page 76.

### Via Web Site

Barco's web site address is: [www.barco.com](http://www.barco.com)

■ To download software from the web site:

1. Create a target folder on your PC (e.g., ACS-2048).
2. Ensure that your PC is connected to the internet.
3. On the web, navigate to:  
**http://www.barco.com**

## 5. Upgrading Software

### Ethernet Upgrade Method

4. Navigate to the “Digital Cinema” home page:  
**`http://www.barco.com/digitalcinema/`**
5. Log in to the **Barco Partnerzone**.
6. Navigate to the “**Software Updates**” link, and download the latest version of code:  
**`ACS2048_##_##.tar.gz`**
7. When the **File Download Dialog** appears, click **Save**.
8. When the **Save As Dialog** appears, navigate to the target folder and click **Save**.
9. Please continue with the “[Ethernet Upgrade Method](#)” section on page 76.

---

## Ethernet Upgrade Method

- Use the following steps to upgrade ACS-2048 software:
  1. Ensure that your PC (or laptop) uses the Windows® 2000 or XP operating systems.
  2. Connect the ACS-2048’s Ethernet port to a Switch.
  3. Connect the Switch to your PC (or laptop).
  4. Power-up the ACS-2048.
  5. Note the ACS-2048’s *current* IP address:
    - a. From the **Main Menu**, select **System** to display the **System Menu**.
    - b. From the **System Menu**, select **Ethernet** to display the **Ethernet Menu**.
    - c. Make a note of the information on the **IP** line, which shows the current IP address in all modes (with DHCP on or off).

### Note

The default IP address is **192.168.000.5**.

6. On your PC (or laptop), open up a web browser.
7. In the browser’s address bar, enter the ACS-2048’s IP address.

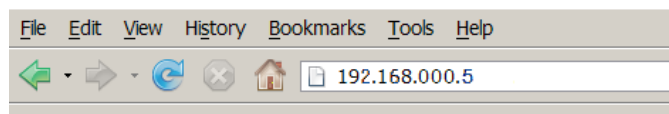

**Figure 5-1.** Address bar with sample IP address

## 5. Upgrading Software

### Ethernet Upgrade Method

- When the PC establishes communications with the ACS-2048, several web pages are downloaded into the PC, and the **ACS-2048 Upgrade Page** appears:

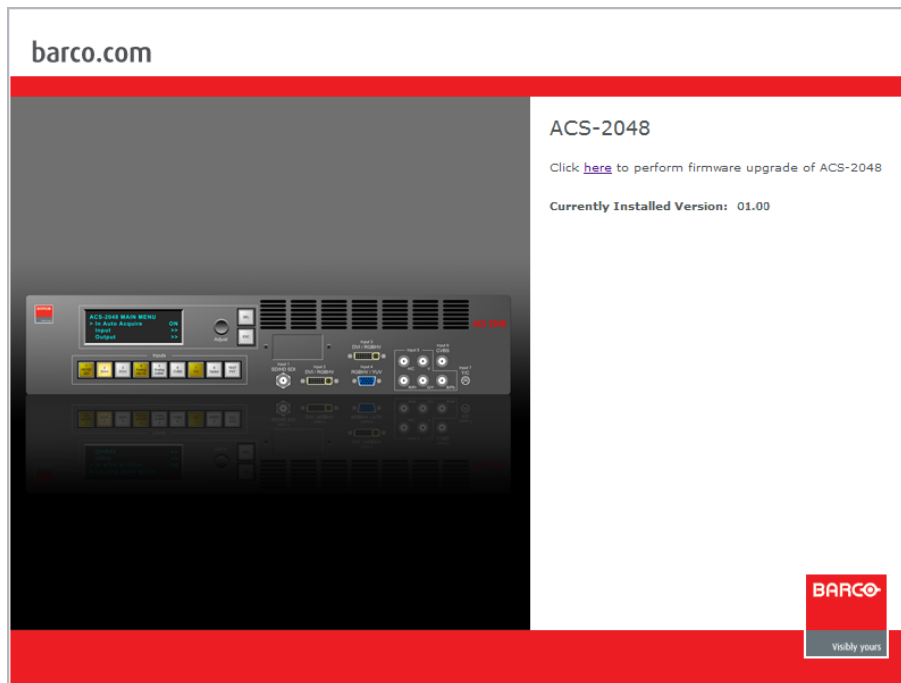

Figure 5-2. ACS-2048 Upgrade Page (sample)

- Click the **Firmware Upgrade** link to continue the upgrade process. The **Select File** page appears, as shown below:

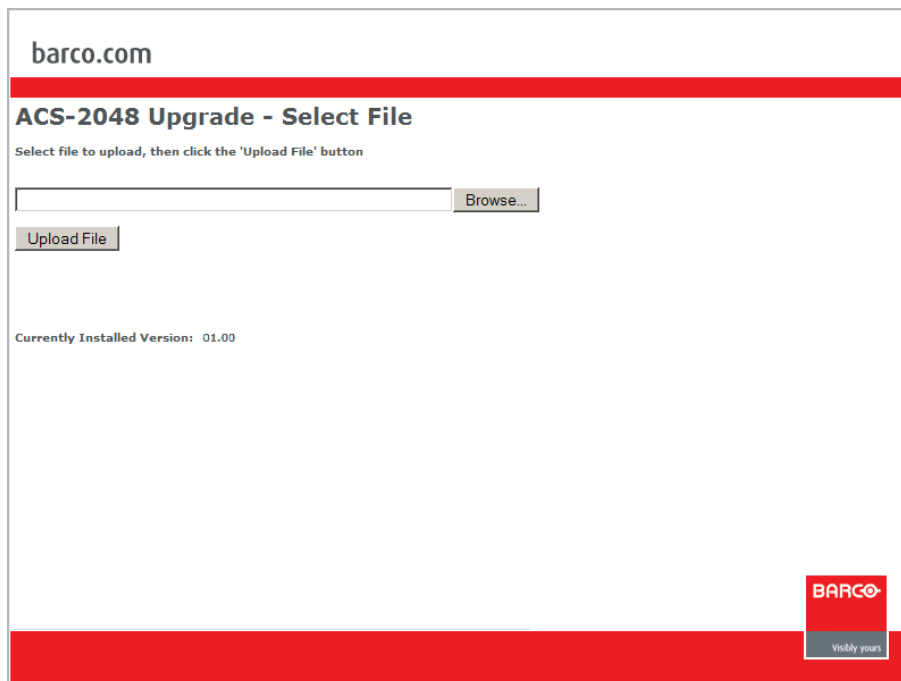

Figure 5-3. ACS-2048 Select File Page (sample)

## 5. Upgrading Software

### Ethernet Upgrade Method

10. Click the **Browse** button, and navigate to the folder on your PC where you saved the latest version of code.
11. In the **Upload Dialog**, select the file:  
**ACS2048\_##\_##\_tar.gz**  
... and click **Open**.
12. In the **Select File** page, click **Upload File**. The **Upload Status** page appears, which provides status during the upload procedure:



**Figure 5-4.** ACS-2048 Upload Status Page (sample)

13. When the procedure is complete, you have three options:
  - ~ Click **Home** to return to the ACS-2048 **Upgrade Page**.
  - ~ If a problem was encountered during the process, click **View Log File** to display a text-based log of the upload procedure.
  - ~ If the upload was successful, click **Restart ACS-2048** to complete the entire procedure.
14. Close your browser, and resume operations on the ACS-2048. Be sure to check the **Software Version Menu** to verify that the system has been updated. From the **Main Menu**, select **Software Version** to display the **Software Version Menu**.

### Troubleshooting Ethernet Communication

- Use the following steps to determine the IP address of the ACS-2048, and establish proper communications:
  1. Power-up the ACS-2048.
  2. Note the ACS-2048's *current* IP address:
    - a. From the **Main Menu**, select **System** to display the **System Menu**.
    - b. From the **System Menu**, select **Ethernet** to display the **Ethernet Menu**.
    - c. Make a note of the information on the **IP** line, which shows the current IP address in all modes (with DHCP on or off).
  3. Attempt to ping the ACS-2048 as follows:
    - a. Connect the ACS-2048's Ethernet port to a Switch.
    - b. Connect the Ethernet Switch to your PC.
    - c. Turn on the PC or laptop.
    - d. Open a command prompt window on the PC. Click **Start > Programs > Accessories > Command Prompt**.
    - e. On the command prompt line, type:

```
ping 192.168.0.5
```

... followed by **Enter**.

#### Note

Use the unit's actual IP address, as determined in step 2 above.

- f. If the computer is able to successfully communicate with the ACS-2048, you will see a series of "**replies**" from the target IP address. Repeat the upgrade procedure as outlined in the "[Ethernet Upgrade Method](#)" section on page 76.
- g. If you see a "**Request timed out**" message, the PC is unable to locate and communicate with the ACS-2048. If this is the case:
  - Check your network connections and settings as described above, or ...
  - Contact your network administrator, or ...
  - Contact **Technical Support**. In Appendix C, refer to the "[Contact Information](#)" section on page 108 for details.

## 5. Upgrading Software

Ethernet Upgrade Method



# A. Specifications

---

## In This Appendix

This appendix provides detailed technical specifications for the ACS-2048. The following topics are discussed:

- [Input Specifications](#)
- [Output Specifications](#)
- [Physical and Electrical Specifications](#)
- [Communications Specifications](#)
- [Agency Specifications](#)
- [Pinouts](#)
- [Input Format Table](#)

## A. Specifications

### Input Specifications

# Input Specifications

The table below lists ACS-2048 input specifications.

**Table A-1.** ACS-2048 Input Specifications

Parameter	Detail	Specification
Input 1	Connector	BNC
	Format	SD-SDI per SMPTE 259M-C (NTSC/PAL resolution)
		HD-SDI per SMPTE 292M (HDTV)
Input 2	Connector	DVI-I, per DDWG 1.0
	Format	8-bit DVI, RGBHV data via analog pins
	HDCP hardware support	HDCP version 1.0 compliant
	Composite, S-Video, YUV	Not supported
Input 3	Connector	DVI-I, per DDWG 1.0
	Format	8-bit DVI, RGBHV data via analog pins
	HDCP hardware support	HDCP version 1.0 compliant
	Composite, S-Video, YUV	Not supported
Input 4	Connector	HD-15 VGA
	Format	YUV and RGBHV
	Sampling	10-bits/color at 170 MHz maximum
		Supports 1:1 sampling up to 1600x1200@60 Hz
		Sources with native pixel rates > 170 MHz will be filtered and undersampled at 170 Mhz, including: <ul style="list-style-type: none"> <li>• 1920x1080p@60 (173.0 MHz)</li> <li>• 1920x1200@60 (193.25 MHz)</li> <li>• 2048x1080p@60 (183.75 MHz)</li> </ul>
	Composite, S-Video	Not supported
Input 5	Connectors	5 x BNC
	Format	YUV and RGBHV
	Sampling	10-bits/color at 170 MHz maximum
		Supports 1:1 sampling up to 1600x1200@60 Hz
		Sources with native pixel rates > 170 MHz will be filtered and undersampled at 170 Mhz, including: <ul style="list-style-type: none"> <li>• 1920x1080p@60 (173.0 MHz)</li> <li>• 1920x1200@60 (193.25 MHz)</li> <li>• 2048x1080p@60 (183.75 MHz)</li> </ul>
	Composite, S-Video	Not supported

## A. Specifications

### Output Specifications

**Table A-1.** ACS-2048 Input Specifications (Continued)

Parameter	Detail	Specification
Input 6	Connector	BNC
	Format	NTSC or PAL video (CVBS)
Input 7	Connector	4-pin mini-DIN
	Format	Encoded NTSC or PAL Y/C video
Input 8	Not currently implemented	

---

## Output Specifications

The table below lists ACS-2048 output specifications:

**Table A-2.** ACS-2048 Output Specifications

Parameter	Detail	Specification
Outputs	Outputs A and B	Dual channel (Twin-Link) DVI output
	Connectors	2 x DVI
	RGB output	Up to 12-bit / color (4:4:4) <ul style="list-style-type: none"><li>• 8 msb on connector A</li><li>• 4 lsb on connector B</li></ul>
		8-bit output on connector A only (user-selectable)
	HDCP Encryption	Connectors A and B
	Supported frame rates	50Hz, 59.94Hz

## A. Specifications

### Physical and Electrical Specifications

---

## Physical and Electrical Specifications

The table below lists ACS-2048 physical and electrical specifications.

**Table A-3.** ACS-2048 Physical and Electrical Specifications

Parameter	Detail	Specification
Power	Connector	Standard IEC, integral on/off switch
	Power	100-240 VAC, 50-60 Hz
Mechanical	Chassis	<b>H:</b> 3.50 inches (8.89 cm)
		<b>W:</b> 17.00 inches (43.18 cm)
		<b>W:</b> 19.00 inches (48.26 cm) with rackmount wings
		<b>D:</b> 10.00 inches (25.4 cm)
Temperature		0-40 degrees C
Humidity		0-95% non-condensing
Mounting		2 RU rack mount
Weight		5.8 lbs (2.63 kg)
Shipping Weight		20 lbs (9.07 kg)

---

## Communications Specifications

The table below lists ACS-2048 communications specifications.

**Table A-4.** ACS-2048 Communications Specifications

Parameter	Detail	Specification
Communications	Ethernet	RJ-45, 10/100 Mbps

---

## Agency Specifications

The table below lists ACS-2048 agency specifications.

**Table A-5.** ACS-2048 Agency Specifications

Parameter	Detail	Specification
Agency Specifications	EMI/EMC	EN55103-1 E4, EN55103-2, FCC Part 15 Subpart B Class A
	Safety	EN 60950 Class 1

## A. Specifications

### Pinouts

---

## Pinouts

The following topics are discussed in this section:

- [Analog 15-pin D Connector](#)
- [DVI-I Connector Pinouts](#)
- [Ethernet Connector](#)
- [Mini-DIN Connector](#)

### Analog 15-pin D Connector

The figure below illustrates the analog 15-pin D connector:

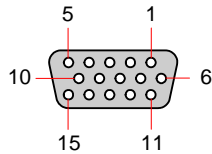

**Figure A-1.** Analog 15-pin D connector, chassis view

The table below lists Analog 15-pin D connector pinouts.

**Table A-6.** Analog 15-pin D Connector Pinouts

Pin	Signal	Pin	Signal
1	Red	9	
2	Green	10	GND
3	Blue	11	
4		12	
5		13	H Sync or C Sync
6	Red return	14	V Sync
7	Green return	15	
8	Blue return		

## DVI-I Connector Pinouts

The figure below illustrates the DVI-I connector:

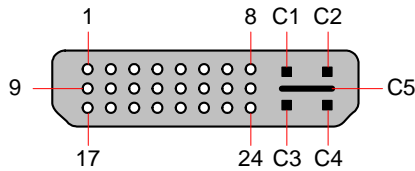

Figure A-2. DVI-I connector

The table below lists DVI-I connector pinouts. Please note:

- T.M.D.S = Transition Minimized Differential Signal
- DDC = Display Data Channel

Table A-7. DVI-I Connector Pinouts

Pin	Signal	Pin	Signal
1	T.M.D.S. Data 2-	13	T.M.D.S. Data 3+
2	T.M.D.S. Data 2+	14	+5V Power
3	T.M.D.S. Data 2/4 Shield	15	ground (for +5V)
4	T.M.D.S. Data 4-	16	Hot Plug Detect
5	T.M.D.S. Data 4+	17	T.M.D.S. Data 0-
6	DDC Clock	18	T.M.D.S. Data 0+
7	DDC Data	19	T.M.D.S. Data 0/5 Shield
8	Analog Vertical Sync	20	T.M.D.S. Data 5-
9	T.M.D.S. Data 1-	21	T.M.D.S. Data 5+
10	T.M.D.S. Data 1+	22	T.M.D.S. Clock Shield
11	T.M.D.S. Data 1/3 Shield	23	T.M.D.S. Clock +
12	T.M.D.S. Data 3-	24	T.M.D.S. Clock -
<b>MicroCross Pins</b>			
C1	Analog Red Video	C4	Analog Horizontal Sync
C2	Analog Green Video	C5	Analog Common Ground Return
C3	Analog Blue Video		

## A. Specifications

### Pinouts

## Ethernet Connector

The figure below illustrates the Ethernet connector:

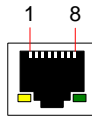

**Figure A-3.** Ethernet connector

The table below lists Ethernet connector pinouts.

**Table A-8.** Ethernet Connector Pinouts

Pin	Signal	Wire Color
1	TX Data +	White / Orange
2	TX Data -	Orange
3	RX Data +	White / Green
4		Blue
5		White / Blue
6	RX Data -	Green
7		White / Brown
8		Brown

## Mini-DIN Connector

The figure below illustrates the **4 pin Mini-DIN** connector.

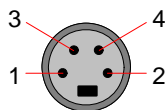

**Figure A-4.** 4 Pin Mini-DIN connector

The table below lists **Mini-DIN** connector pinouts.

**Table A-9.** Mini-DIN Connector Pinouts

Pin	DMX Signal	Description
1	C	Chrominance
2	Y	Luminance
3	Gnd	Ground
4	Gnd	Ground



---

## Input Format Table

The table below lists the available input formats for the ACS-2048. Each entry uses the following convention: **Format @Fv (Hz)**.

**Table A-10.** ACS-2048 Input Formats

Format	Aspect Ratio	Color Space
NTSC (480i)	1.33333	SMPTE, RGB
720x480p	1.33333	SMPTE, RGB
PAL (576i)	1.33333	SMPTE, RGB
720x575p	1.33333	SMPTE, RGB
640x480 @59.94	1.33333	RGB
640x480 @60	1.33333	RGB
640x480 @72	1.33333	RGB
640x480 @75	1.33333	RGB
640x480 @85	1.33333	RGB
800x600 @50	1.33333	RGB
800x600 @56	1.33333	RGB
800x600 @59.94	1.33333	RGB
800x600 @60	1.33333	RGB
800x600 @72	1.33333	RGB
800x600 @75	1.33333	RGB
800x600 @85	1.33333	RGB
1024x768 @47.95	1.33333	RGB
1024x768 @48	1.33333	RGB
1024x768 @50	1.33333	RGB
1024x768 @59.94	1.33333	RGB
1024x768 @60	1.33333	RGB
1024x768 @70	1.33333	RGB
1024x768 @71.93	1.33333	RGB
1024x768 @72	1.33333	RGB
1024x768 @75	1.33333	RGB
1024x768 @85	1.33333	RGB
1152x864 @75	1.33333	RGB
1280x720 @60	1.77778	RGB

## A. Specifications

### Input Format Table

**Table A-10.** ACS-2048 Input Formats (Continued)

Format	Aspect Ratio	Color Space
1280x720 II @60	1.77778	RGB
1280x768 @47.95	1.66667	RGB
1280x768 @48	1.66667	RGB
1280x768 @50	1.66667	RGB
1280x768 @59.94	1.66667	RGB
1280x768 @75	1.66667	RGB
1280x800 @60	1.60	RGB
1280x800 II @60	1.60	RGB
1280x960 @50	1.33333	RGB
1280x960 @59.94	1.33333	RGB
1280x960 @60	1.33333	RGB
1280x960 @85	1.33333	RGB
1280x1024 @47.95	1.25	RGB
1280x1024 @48	1.25	RGB
1280x1024 @50	1.25	RGB
1280x1024 @59.94	1.25	RGB
1280x1024 @60	1.25	RGB
1280x1024 @71.93	1.25	RGB
1280x1024 @72	1.25	RGB
1280x1024 @75	1.25	RGB
1280x1024 @85	1.25	RGB
1360x768 @60	1.77083	RGB
1364x768 @47.95	1.77778	RGB
1364x768 @48	1.77778	RGB
1364x768 @50	1.77778	RGB
1364x768 @59.94	1.77778	RGB
1364x768 @75	1.77778	RGB
1364x1024 @47.95	1.33333	RGB
1364x1024 @48	1.33333	RGB
1364x1024 @50	1.33333	RGB
1364x1024 @59.94	1.33333	RGB
1364x1024 @75	1.33333	RGB
1366x768 @50	1.77778	RGB

**Table A-10.** ACS-2048 Input Formats (Continued)

Format	Aspect Ratio	Color Space
1366x768 @59.94	1.77778	RGB
1400x1050 @48	1.33333	RGB
1400x1050 @50	1.33333	RGB
1400x1050 @59.94	1.33333	RGB
1400x1050 @60	1.33333	RGB
1400x1050 @75	1.33333	RGB
1440x900 @60	1.60	RGB
1440x900 @75	1.60	RGB
1440x900 @85	1.60	RGB
1536x768 @50	2	RGB
1536x768 @59.94	2	RGB
1680x1050 @60	1.6	RGB
1600x1200 @47.95	1.33333	RGB
1600x1200 @48	1.33333	RGB
1600x1200 @50	1.33333	RGB
1600x1200 @59.94	1.33333	RGB
1600x1200 @60	1.33333	RGB
1280x720p @48	1.77778	SMPTE, RGB
1280x720p @50	1.77778	SMPTE, RGB
1280x720p @59.94	1.77778	SMPTE, RGB
1280x720p @60	1.77778	SMPTE, RGB
1680x1050 @60	1.60	RGB
1920x1080p @23.98	1.77778	SMPTE, RGB
1920x1080p @24	1.77778	SMPTE, RGB
1920x1080p @25	1.77778	SMPTE, RGB
1920x1080p @29.97	1.77778	SMPTE, RGB
1920x1080p @30	1.77778	SMPTE, RGB
1920x1080p @48	1.77778	SMPTE, RGB
1920x1080p @50	1.77778	SMPTE, RGB
1920x1080p II @50	1.77778	SMPTE, RGB
1920x1080p @59.94	1.77778	SMPTE, RGB
1920x1080p @60	1.77778	SMPTE, RGB
1920x1080sF@23.98	1.77778	SMPTE, RGB

## A. Specifications

### Input Format Table

**Table A-10.** ACS-2048 Input Formats (Continued)

<b>Format</b>	<b>Aspect Ratio</b>	<b>Color Space</b>
1920x1080sF@24	1.77778	SMPTE, RGB
1920x1080i @50	1.77778	SMPTE, RGB
1920x1080i @59.94	1.77778	SMPTE, RGB
1920x1080i @60	1.77778	SMPTE, RGB
2048x1080p @48	1.8963	RGB
2048x1080p @50	1.8963	RGB
2048x1080p II @50	1.8963	RGB
2048x1080p @59.94	1.8963	RGB
2048x512p @59.94	4	RGB
2048x1080p @60	1.77778	RGB
1920x1200p @60	1.77778	RGB
1920 x 1200 II @60	1.77778	RGB
1920 x 1080 II @60	1.77778	RGB, SMPTE
2048 x 1080 II @60	1.7778	RGB
Apple 1200p @60	1.6	RGB
875p	1.33333	RGB

## B. Remote Control Protocol

---

### In This Appendix

This appendix provides information regarding remote control protocol. The following topics are discussed:

- [Communicating with ACS-2048](#)
  - [Command Protocol](#)
  - [Error Codes](#)
  - [ACS-2048 Command List](#)
  - [Remote Commands](#)
- 

### Communicating with ACS-2048

- Use the following steps to communicate with the ACS-2048 via Telnet:
  1. Connect the ACS-2048's Ethernet port to an Ethernet switch, and connect the switch to your PC or laptop.
  2. Ensure that all Ethernet parameters are properly set up. In Chapter 4, refer to the "[Ethernet](#)" section on page 58 for details.
  3. For Telnet communications, use the ACS-2048's IP address and port 23. On a Microsoft Windows PC, open a command prompt window and enter the following:

```
> telnet xxx.xxx.xxx.xxx 23
```

4. After you "Telnet" into the ACS-2048, you are presented with the login prompt:

```
Welcome to ACS-2048.  
Login as "user".  
Press <ENTER> for password.
```

- a. Type "user" and press **ENTER** to login.
- b. When prompted for a password, simply press **ENTER**.

Once you have successfully logged in, the following message appears, along with the command prompt (>):

```
ShellApp waiting for input  
>
```

5. You can now issue commands. Operationally, the telnet window functions in a manner similar to a serial communications session. As required, type "**help**" to see a list of supported commands.

Refer to the "[Remote Commands](#)" section on page 98 for a complete list of commands.

## B. Remote Control Protocol

### Command Protocol

---

## Command Protocol

The ACS-2048's command protocol is compatible with GNU getopt parsing. Every parameter of the command has an option character associated with it. A **<CR>** carriage return (**ASCII 13**) terminates the command.

#### Note

The order of the option characters in the command does not matter.

#### ▲ Command example:

```
ITYPE -i 2 -t 1<CR>
```

Or

```
ITYPE -t 1 -i 2<CR>
```

## Command Responses

A command response is sent after each command is processed. This response consists of the command, followed by the error code, a line feed **<LF>** and a special termination character (**\x4**).

- When a command is successful, the error code is a **0 (eERR\_OK)**, or some positive value.
- When a command is not successful, the error code is a negative value. A preliminary list of the error codes is included. Refer to the "[Error Codes](#)" section on page 96 for details.

#### ▲ Command response example:

```
ITYPE -e 0<LF>
```

```
</x4>
```

## Query Options

Query type options are available for the commands. The order of precedence for processing query option arguments is help (**--help**), query (**-?**), and list (**--list**). If more than one query option is sent in a command, the option with the highest precedence is processed, and any others are ignored.

**Help Query** — Commands have a "**help**" query option associated with them, (**--help**). This query lists all option flags and parameters for the command in the following format:

#### ▲ Help option example:

```
IBRT --help<CR>
```

#### ▲ Response:

### IBRT

- **Description:** Input Brightness Adjust
- **Command Format:** IBRT -i(input) -b(bright)

- **Parameters:**
  - i(input): Input number, 1-8
  - b(bright): 75.0%-125.0%
- **Query Format:** IBRT i(input) -?
- **Query Response:** IBRT i(input) b(bright) --min 75 --max 125  
IBRT -e 0 <LF>  
</x4>

**Current Setting Query** — The current setting query option (-?) returns the command with each of the current parameter settings. Commands with minimum and maximum settings for the parameter will have these “min” and “max” values returned with option flags **--min** and **--max**.

- ▲ Query option example:

```
IBRT -i 4 -?<CR>
```

- ▲ Response:

```
IBRT -i 4 -b 100.00 --min 75 --max 125  
IBRT -e 0<LF>  
</x4>
```

Several commands have a list for the associated valid parameter values, such as the format commands. The list of these values can be queried with the list query option (**--list**). The list shows has the numeric value for the parameter, followed by the value text encased in quotes. A colon separates the numeric value from the string.

- ▲ List query option example:

```
ISMP -i 4 --list<CR>
```

- ▲ Response:

```
0: "OverSample"  
1: "1:1"  
ISMP -e 0<LF>  
</x4>
```

## B. Remote Control Protocol

### Error Codes

---

## Error Codes

This section provides ACS-2048 error codes:

### Error Codes: General Failures

The table below lists general failure codes:

**Table B-1.** ACS-2048 General Error Codes

Code	Description
-9999	Generic fail
-9998	Operation is not applicable in current state
-9997	UI Related... Did not get response from device
-9996	UI Related... Did not get valid response from device
-9995	Timeout occurred
-9994	Parameter / data out of range
-9993	Searching for data in a index, no matching data
-9992	Checksum didn't match
-9991	Version didn't match
-9990	UI Related... Current device interface not supported
-9989	Pointer operation invalid
-9988	Part of command had error
-9987	Buffer overflow
-9986	Initialization is not done

### Error Codes: No Error

The table below lists the "no error" code:

**Table B-1.** ACS-2048 "No Error" Code

Code	Description
0	Successful



## ACS-2048 Command List

The table below lists ACS-2048 remote commands.

Table B-1. ACS-2048 Remote Commands

Command	Description	Page
<a href="#">AUTOACQ</a>	Auto Input Acquisition Mode	98
<a href="#">AUTOSAVE</a>	Auto Input Settings Save	98
<a href="#">BLKVID</a>	Puts black into the scaler selected	98
<a href="#">CONTEXT</a>	Sets menu context	99
<a href="#">DHCP</a>	Enable/Disable DHCP mode	99
<a href="#">EMAC</a>	Get MAC Address	99
<a href="#">GATEWAY</a>	Set gateway to be used when DHCP is OFF	99
<a href="#">ICDEL</a>	Deletes input configuration	99
<a href="#">ICLIST</a>	Returns list of saved input configurations, input type and format resolution	100
<a href="#">ICREC</a>	Recalls saved input configuration for selected input	100
<a href="#">ICSAV</a>	Saves Input Configuration	100
<a href="#">IHCROP</a>	Input Horizontal Crop	101
<a href="#">IHPAN</a>	Input Horizontal Pan	101
<a href="#">IMAP</a>	Associates specified input file configuration with selected input	101
<a href="#">IP</a>	Set Static IP Address to be used when DHCP is OFF	101
<a href="#">ISEL</a>	Selects the selected input as the current input to display	102
<a href="#">ISTAT</a>	Query only command for the input status type and format.	102
<a href="#">IVCROP</a>	Input Vertical Crop	102
<a href="#">IVPAN</a>	Input Vertical Pan	102
<a href="#">LOCKOUT</a>	Controls the lockout mode of the front panel	102
<a href="#">OCSAV</a>	Save Output Configuration	103
<a href="#">OGM</a>	Set Output Gamma	103
<a href="#">OMODE</a>	Set the output mode	103
<a href="#">ORBM</a>	Output Raster Box Mode	103
<a href="#">ORES</a>	Output Resolution	104
<a href="#">OSTAT</a>	Query only command for the output status type and format	104
<a href="#">OTPM</a>	Output Test Pattern Mode	104
<a href="#">OTPT</a>	Output Test Pattern Type	104
<a href="#">RESET</a>	Reset unit	105

## B. Remote Control Protocol

### Remote Commands

Table B-1. ACS-2048 Remote Commands (Continued)

Command	Description	Page
<a href="#">SAVE</a>	System Save	105
<a href="#">SELMODE</a>	Sets whether input selection of inputs w/o valid syncs will be made	105
<a href="#">SUBNET</a>	Set subnet mask to be used when DHCP is OFF	106
<a href="#">TEMP</a>	Query only command for the temperature of the unit	106
<a href="#">TRNTIME</a>	Set transition time	106
<a href="#">VER</a>	Display Version info	106
<a href="#">VFDBRT</a>	Set VFD brightness	106

---

## Remote Commands

This section lists ACS-2048 remote commands.

### AUTOACQ

- **Description:** Auto Input Acquisition Mode.
- **Command Format:** AUTOACQ -m (mode)
- **Command Params:** -m mode: 0-off, 1-on (Default: on)
- **Query Format:** AUTOACQ -?
- **Query Response:** AUTOACQ -m (mode) --min 0 --max 1

### AUTOSAVE

- **Description:** Auto Input Settings Save
- **Command Format:** AUTOSAVE -m (mode)
- **Parameters:** -m (mode): 0 - off, 1 - on (default: off)
- **Query Format:** AUTOSAVE -?
- **Query Response:** AUTOSAVE -m (mode) --min 0 -- max 1

### BLKVID

- **Description:** Puts black into the scaler selected.
- **Command Format:** BLKVID -s (scaler) -m (mode)
- **Parameters:**
  - s (scaler): 1 - 2
  - m (mode): 0 - off, 1 - on
- **Query Format:** N/A
- **Query Response:** N/A

### CONTEXT

- **Description:** Sets menu context
- **Command Format:** CONTEXT -m (mode)
- **Parameters:** -m (mode): 0 - off, 1 - on
- **Query Format:** CONTEXT -?
- **Query Response:** CONTEXT -m (mode) --min 0 -- max 1

### DHCP

- **Description:** Enable/Disable DHCP mode
- **Command Format:** DHCP -m (mode)
- **Command Params:** -m mode: 0-disable, 1-enable (default: on)
- **Query Format:** DHCP -?
- **Query Response:** DHCP -m (mode) --min 0 --max 1

### EMAC

- **Description:** Get MAC Address
- **Command Format:** N/A
- **Command Params:** N/A
- **Query Format:** EMAC -?
- **Query Response:** EMAC -a (addr)
- **Response Params:** -a (addr): MAC address formatted xx.xx.xx.xx.xx.xx

### GATEWAY

- **Description:** Set gateway to be used when DHCP is OFF
- **Command Format:** GATEWAY -s (static addr)
- **Command Params:** s static addr: format will be: xxx.xxx.xxx.xxx
- **Query Format:** GATEWAY -?
- **Query Response:** GATEWAY -a (active addr) -s (static addr)
- **Query Params:** -a (active addr): Active gateway active address

### ICDEL

- **Description:** Deletes input configuration.
- **Command Format:** ICDEL -i (input) -f (file)
- **Parameters:**
  - i (input): 1 - 8
  - f (file): 1 - 64. (optional)
- **Query Format:** N/A
- **Query Response:** N/A

## B. Remote Control Protocol

### Remote Commands

#### ICLIST

- **Description:** This is an informational command that returns a list of the saved input configurations, their input type and format resolution.
- **Command Format:** ICLIST
- **Command Response:**

```
Saved Input Configurations
File      Type      Format
====      =====  =====
1         SDI       1920x1080i @59.94
2         DVI       1920x1080p @60.00
ICLIST -e 0
```

#### ICREC

- **Description:** Recalls the saved input configuration for the selected input. The selected input's file association is updated and the settings in the input configuration file are applied if the **-f (file)** parameter is specified.

- **Command Format:** ICREC -i (input) -f (file)

- **Parameters:**

```
-i (input):1 - 8
-f (file): 1 - 64 (optional)
```

- **Query Format:** ICREC -i (input) -?
- **Query Response:** ICREC -i (input) -f (file)
- **List Format:**

```
ICREC -i (input) -list
The list returns all saved input configurations.
```

- **List Response:**

```
1: "1"
2: "2"
7: "7"
28: "28"
ICREC -e 0
```

#### ICSAV

- **Description:** Saves Input Configuration. The selected input's file association is updated if the **-f (file)** parameter is specified.

- **Command Format:** ICSAV -i (input) -f (file)

- **Parameters:**

```
-i (input):1 - 8
-f (file): 1 - 64. (optional)
```

- **Query Format:** N/A

- **Query Response:** N/A

### IHCROP

- **Description:** Input Horizontal Crop
- **Command Format:** IHCROP -i (input) -w (width)
- **Parameters:**
  - i (input): 1 - 8
  - w (width): In pixels
- **Query Format:** IHCROP -i (input) -?
- **Query Response:** IHCROP -i (input) -w(width) --min (pos min) -- max (pos max)

### IHPAN

- **Description:** Input Horizontal Pan
- **Command Format:** IHPAN -i (input) -p (pan)
- **Parameters:**
  - i (input): 1 - 8
  - p (pan): In pixels
- **Query Format:** IHPAN -i (input) -?
- **Query Response:** IHPAN -i (input) -p (pan) --min (active min) -- max (active max)

### IMAP

- **Description:** Associates the specified input file configuration with the selected input.
- **Command Format:** IMAP -i (input) -f (file)
- **Parameters:**
  - i (input): 1 - 8
  - f (file): 1 - 64.
- **Query Format:** IMAP -i (input) -?
- **Query Response:** IMAP -i (input) -f (file)

### IP

- **Description:** Set Static IP Address to be used when DHCP is OFF
- **Command Format:** IP -s (static)
- **Command Params:** -s static addr with format xxx.xxx.xxx.xxx
- **Query Format:** IP -?
- **Query Response:** IP -a (active addr) -s (static addr)
- **Response Params:** -a (active addr): returns active address

## B. Remote Control Protocol

### Remote Commands

#### ISEL

- **Description:** Selects the specified input as the current input to display. This command will perform the valid sync check, route the input, recall video if saved or acquire source if not saved. The selected input's file association is updated and the settings in the input configuration file are applied if the **-f (file)** parameter is specified.
- **Command Format:** ISEL -i (input) -f (file)
- **Parameters:**
  - i (input): 1 - 8
  - f (file): 1 – 64 (optional)
- **Query Format:** ISEL -?
- **Query Response:** ISEL -i (input)

#### ISTAT

- **Description:** Query only command for the input status type and format.
- **Query Format:** ISTAT -?
- **Query Response:** ISTAT -t "(input type)" -f "(input format)"

#### IVCROP

- **Description:** Input Vertical Crop
- **Command Format:** IVCROP -i (input) -h (height)
- **Parameters:**
  - i(input): 1 - 8
  - h(height): In lines
- **Query Format:** IVCROP -i(input) -?
- **Query Response:** IVCROP -i(input) -h(height) --min (pos min) -- max (pos max)

#### IVPAN

- **Description:** Input Vertical Pan
- **Command Format:** IVPAN -i (input) -p (pan)
- **Parameters:**
  - i (input): 1 - 8
  - p (pan): In pixels
- **Query Format:** IVPAN -i (input) -?
- **Query Response:** IVPAN -i (input) -p (pan) --min (active min) -- max (active max)

#### LOCKOUT

- **Description:** Controls the lockout mode of the front panel. When enabled, the keys and menu will be deactivated.
- **Command Format:** LOCKOUT -m (mode)

- **Parameters:** -m (mode): 0 - disable, 1 - enable (default: disable)
- **Query Format:** LOCKOUT -?
- **Query Response:** LOCKOUT -m (mode) --min 0 -- max 1

### OCSAV

- **Description:** Save Output Configuration
- **Command Format:** OCSAV
- **Parameters:** N/A
- **Query Format:** N/A
- **Query Response:** N/A

### OGM

- **Description:** Set Output Gamma
- **Command Format:** OGM -o (output) -g (gamma)
- **Parameters:**
  - o output: 1 - DVI
  - g gamma: 1.0 to 3.0; +0.1 increment (Default: 1.0)
- **Query Format:** OGM -o (output) -?
- **Query Response:** OGM -o (output) -g (gamma) --min 1 -- max 3

### OMODE

- **Description:** Set the output mode
- **Command Format:** OMODE -o (output) -w (width)
- **Parameters:**
  - o (output): 1 - DVI
  - w (width): 0 - 8 bits, 1 - 10 bits, 2 - 12 bits (Default: 10 bits)
- **Query Format:** OMODE -o (output) -?
- **Query Response:** OMODE -o (output) -w(width) --min 0 -- max 2
- **List Format:** OMODE -o (output) --list
- **List Response:**
  - 0: "8 bits"
  - 1: "10 bits"
  - 2: "12 bits"

### ORBM

- **Description:** Output Raster Box Mode
- **Command Format:** ORBM -o (output) -m (mode)
- **Parameters:**
  - o (output): 1 - DVI
  - m (mode): 0-off, 1-on

## B. Remote Control Protocol

### Remote Commands

- **Query Format:** ORBM -o (output) -?
- **Query Response:** ORBM -o (output) -m (mode) --min 0 -- max 1

### ORES

- **Description:** Output Resolution
- **Command Format:** ORES -o (output) [-f (format) | -n (index)]
- **Parameters:**
  - o (output): 1 - DVI
  - f (format): format string, i.e. "2048x1080 @60"  
(Default: 2048x1080 @ 59.94)
  - or
  - n (index): video format index (see VHELP)
- **Query Format:** ORES -o (output) -?
- **Query Response:** ORES -o (output) -f(format)
- **List Format:** ORES -o (output) --list
- **List Response:**
  - 90:"2048x1080p @50"
  - 92:"2048x 1080p @59.94"

### OSTAT

- **Description:** Query only command for the output status type and format.
- **Query Format:** OSTAT -?
- **Query Response:** OSTAT -t "(output type)" -f "(output format)"

### OTPM

- **Description:** Output Test Pattern Mode
- **Command Format:** OTPM -o (output) - m (mode)
- **Parameters:**
  - o (output): 1 - DVI
  - m (mode): 0 - off, 1 - on
- **Query Format:** OTPM -o (output) -?
- **Query Response:** OTPM -o (output) - m (mode) --min 0 -- max 1

### OTPT

- **Description:** Output Test Pattern Type
- **Command Format:** OTPT -o (output) - t (type)
- **Parameters:**
  - o (output): 1 - DVI
  - t (type):
    - 1 - H Ramp



- 2 - V Ramp
  - 3 - 100% Col Bars
  - 4 - 16x16 Grid
  - 5 - 32x32 Grid
  - 6 - Burst
  - 7 - 75% Col bars
  - 8 - 50% Gray
  - 9 - Gray Steps 1
  - 10 - Gray Steps 2
- **Query Format:** OTPT -o (output) -?
  - **Query Response:** OTPT -o (output) - t (type) --min 1 -- max 10
  - **List Format:** OTPT -o (output) --list
  - **List Response:**

1: "H Ramp"	6: "Burst"
2: " V Ramp"	7: "75% Col bars"
3: "100% Col Bars"	8: "50% Gray"
4: "16x16 Grid"	9: "Gray Steps 1"
5: "32x32 Grid"	10: "Gray Steps 2"

### RESET

- **Description:** Reset unit
- **Command Format:** RESET [-f | -s ]
- **Parameters:**
  - f : factory reset
  - Or
  - s: soft reset
- **Query Format:** N/A
- **Query Response:** N/A

### SAVE

- **Description:** System Save
- **Command Format:** SAVE
- **Parameters:** N/A
- **Query Format:** N/A
- **Query Response:** N/A

### SELMODE

- **Description:** Sets whether input selection of inputs w/o valid syncs will be made.
- **Command Format:** SELMODE -m (mode)
- **Parameters:** -m (mode): 0 - don't allow selection, 1 - allow selection (Default: off)
- **Query Format:** SELMODE -?

## B. Remote Control Protocol

### Remote Commands

- **Query Response:** SELMODE -m (mode) --min 0 -- max 1

#### SUBNET

- **Description:** Set subnet mask to be used when DHCP is OFF
- **Command Format:** SUBNET -s (static addr)
- **Command Params:** -s static address formatted xxx.xxx.xxx.xxx
- **Query Format:** SUBNET -?
- **Query Response:** SUBNET -a(active addr) -s(static addr)
- **Response Params:** -a(active addr): returns active address

#### TEMP

- **Description:** Query only command for the temperature of the unit.
- **Query Format:** TEMP -?
- **Query Response:** TEMP -c (celsius) -f (fahrenheit)

#### TRNTIME

- **Description:** Set transition time
- **Command Format:** TRNTIME -s (seconds)
- **Parameters:** -s (seconds): 1.5 - 5.0 (default: 1.5)
- **Query Format:** TRNTIME -?
- **Query Response:** TRNTIME -s (seconds) --min 1.5 -- max 5

#### VER

- **Description:** Display Version info
- **Command Format:** VER
- **Parameters:** N/A
- **Query Format:** N/A
- **Query Response:** N/A

#### VFDBRT

- **Description:** Set VFD brightness
- **Command Format:** VFDBRT -b (brightness) -f
- **Parameters:**
  - b (brightness): 1 - 16 (default: 10)
  - f: Command from front panel
- **Query Format:** VFDBRT -?
- **Query Response:** VFDBRT -b (brightness) --min 1 -- max 16

## C. Contact Information

---

### In This Appendix

The following topics are discussed in this Appendix:

- [Warranty](#)
  - [Return Material Authorization \(RMA\)](#)
  - [Contact Information](#)
- 

### Warranty

All video products are designed and tested to the highest quality standards and are backed by a full 3-year parts and labor warranty. Warranties are effective upon delivery date to customer and are non-transferable. Barco warranties are only valid to the original purchaser/owner. Warranty related repairs include parts and labor, but do not include faults resulting from user negligence, special modifications, lightning strikes, abuse (drop/crush), and/or other unusual damages.

The customer shall pay shipping charges when unit is returned for repair. Barco will cover shipping charges for return shipments to customers.

---

### Return Material Authorization (RMA)

In the unlikely event that a product is required to return for repair, please call the following number and ask for a Sales Engineer to receive a Return Merchandise Authorization number (RMA).

- (888) 414-7226

RMA Conditions are listed below:

- a. Prior to returning any item, you must receive a Return Merchandise Authorization (RMA) number.
- b. All RMA numbers must appear on their return-shipping label.
- c. RMA numbers are valid for ten (10) days from issue date.
- d. All shipping and insurance charges on all RMAs must be prepaid by the customer

## C. Contact Information

Contact Information

---

### Contact Information

#### **Barco Media and Entertainment**

11101 Trade Center Drive  
Rancho Cordova, California 95670  
USA

- Phone: (916) 859-2500
- Fax: (916) 859-2515
- Website: [www.barco.com](http://www.barco.com)

#### **Sales Contact Information**

- Direct: (916) 859-2505
- Toll Free: (888) 414-7226
- E-mail: [folsomsales@barco.com](mailto:folsomsales@barco.com)

#### **Barco N.V.**

Noordlaan 5  
8520 Kuurne  
BELGIUM

- Phone: +32 56.36.82.11
- Fax: +32 56.35.16.51
- Website: [www.barco.com](http://www.barco.com)

#### **Technical Support Information**

- Tech Line: (866) 469-8036 — 24 hours per day, 7 days per week

# Index

## Numerics

10/100BaseT	23
1-1 Sampling	49
3-2 film pulldown	50

## A

### AC

connector	24
power and voltage selection	28
power cords	28
power installation	27

Acrobat usage	12
navigating and searching	12

### ACS-2048

block diagram	16
command list	97
communicating with	93
communications connections	30
connectivity diagram	16
control overview	32
features	13
front panel	18
hardware installation	25
hardware orientation	17
input connections	29
introduction to	11
menu tree	35
operation	31
output connections	30
rear panel connectors	23
remote commands	98
remote control protocol	93
restart	78
specifications	81
system diagram	29
upgrade page	77
upgrading software	73

Adapter information	26
---------------------	----

### Address

company	3
IP	60

MAC	60
ADJUST	
knob	19, 20
using knob	36
Adjust	
brightness	47
color balance	47
colorspace	45
contrast	47
EDID	60
hue/saturation color balance	48
image	46
input format	44
input parameters	46
input type	44
output format	53
output gamma	54
output mode	53
output size and position	13, 55
processing	50
raster box	55
RGB color balance	47
test pattern	54
timing	48
transition time	57
VFD brightness	58
Agency specifications	85
All Inputs Sel	63
Analog 15-pin D connector pinouts	86
Application questions	16
Aspect Ratio	46
Association, file	64
Asterisks	44
Auto	
config	46, 48
input save	63
sync	50
Auto acquire	
mode	42
understanding	70
AUTOACQ (command)	98
AUTOSAVE (command)	98

# Index

## B

Backlighting, understanding	69
Barco	
contact information	108
sales contact information	108
technical support information	3, 108
warranty	107
Best guess format	44
Blinking button	21
BLKVID (command)	98
Block diagram	16
BNC breakout cable	30
Brackets	44
Breakout cable	30
Bright yellow button	21
Brightness	47
VFD	58
Button	
backlighting, understanding	69
blinking	69
bright yellow	69
dim yellow	69
off	69
test pat	71
Button state	
blinking	21
bright yellow	21
dim yellow	21
off	21

## C

Cable	
breakout	30
equalization	62
information	26
Change history	6
Chapter structure	11
Chassis internal temperature	62
Color balance	47
Colorspace	45
Command	
AUTOACQ	98
AUTOSAVE	98
BLKVID	98
CONTEXT	99
DHCP	99
EMAC	99
GATEWAY	99
ICDEL	99
ICLIST	100
ICREC	100
ICSAV	100
IHCROP	101

IHPAN	101
IMAP	101
IP	101
ISEL	102
ISTAT	102
IVCROP	102
IVPAN	102
list	97
LOCKOUT	102
OCSAV	103
OGM	103
OMODE	103
ORBM	103
ORES	104
OSTAT	104
OTPM	104
OTPT	104
protocol	94
remote	98
RESET	105
responses	94
SAVE	105
SELMODE	105
SUBNET	106
TEMP	106
TRNTIME	106
VER	106
VFDBRT	106
Communicating with ACS-2048	93
Communications	
connections	30
specifications	85
Communicator touch screen	32
Company address	3
Components, front panel	18
Config	
network	58, 59
save system	65
Configuration	
delete input	52
recall input	52
reset input	50
save input	51
save output	56
Connection, format table	30
Connectivity diagram	16
Connector	
AC	24
analog 15-pin D pinouts	86
DVI-I pinouts	87
Ethernet	23
Ethernet pinouts	88
input 1	18
input 2	18
input 3	18
input 4	19
input 5	19

## Index

input 6	19
input 7	19
rear panel	23
Contact information	108
CONTEXT (command)	99
Context, menu	63
Contrast	47
Control overview	32
Conventions	12
menu system	36
Copy protection	15
Copyright	2
Crop	46
CSync	50
Cursor	20
edit	36
navigation	36
Custom aspect ratio	46

## D

Delay, video	14
Delete	
config	52
input configuration	52
DHCP	58, 99
Diagnostics menu	65
Diagram	
connectivity	16
system	29
Digital cinema	13
Dim yellow button	21
Display	20
brightness	58
section	19, 20
Documentation conventions and symbols	12
Double arrow	20
Download software	75
via FTP site	75
via web site	75
DVI	
cable equalization	62
cable equalizer menu	62
outputs	23
twin-link output	23
DVI-I	18
DVI-I connector pinouts	87
DVI-I output connectors	53

## E

EDID	
DVI input format	60
DVI input format menu	60

format	61
input	61
program	61
Edit cursor	36
Electrical specifications	84
EMAC	99
Encryption, HDCP	23
Equalization	62
set to default	62
Equipment marking terms	5
Error codes	96
general failures	96
no error	96
ESC	20
using	36, 37
Ethernet	
address	59
connector	23
connector pinouts	88
Menu	58
troubleshoot connection	79
Extended Display Identification Data	60

## F

Factory	
default	68
reset	68
reset menu	68
FCC statement	2
Features, ACS-2048	13
File	
association	64
association menu	64
Format	
asterisks	44
best guess	44
brackets	44
connection table	30
input	44
output	53
Frame rates	23
Front panel	
components	18
display section	19
lockout	72
FTP site	75
Function, quick reference table	38

## G

Gamma	54
Gateway	
menu	59

# Index

set .....	59
GATEWAY (command) .....	99
Guarantee and compensation .....	2

## H

### H

active .....	49
crop .....	46
pan .....	46
position .....	49
total .....	49
Hardware .....	
installation .....	25
orientation .....	17
requirements, upgrading software .....	74
HD-15 .....	19
HDCP .....	13, 15
encryption .....	23
repeater .....	15, 67
status .....	67
violation .....	67
HD-SDI .....	18
High-Bandwidth Digital Content Protection .....	15
History, change .....	6
How to .....	
communicate with ACS-2048 .....	93
download software from FTP site .....	75
download software from website .....	75
install power .....	27
install signals to/from ACS-2048 .....	29
lock/unlock front panel .....	72
power up .....	32
troubleshoot Ethernet connection .....	79
upgrade software via Ethernet .....	76
use menu system .....	36
use TEST PAT button .....	22
use the main menu .....	41
use this guide .....	12
Hue .....	48
Hue/Saturation color balance menu .....	48
Hyperlinks .....	12

## I

ICDEL (command) .....	99
ICLIST (command) .....	100
ICREC (command) .....	100
ICSAV (command) .....	100
IHCROP (command) .....	101
IHPAN (command) .....	101
Image adjust menu .....	46
IMAP .....	101
In Auto Acquire .....	42

Information, cables and adapters .....	26
Input .....	

colorspace .....	45
configuration files .....	51
connections .....	29
connector 1 .....	18
connector 2 .....	18
connector 3 .....	18
connector 4 .....	19
connector 5 .....	19
connector 6 .....	19
connector 7 .....	19
delete configuration .....	52
DVI cable equalizer .....	62
format .....	44, 67
format table .....	89
menu .....	43
menu context .....	70
processing .....	50
recall configuration .....	52
reset configuration .....	50
save configuration .....	51
selection rules .....	69
specifications .....	82
type .....	44, 67

### Inputs

section .....	19, 21
universal .....	13
using .....	69

Inspection .....	26
------------------	----

### Installation

hardware .....	25
power .....	27
rack mount .....	27
safety precautions .....	26
signals .....	29
site preparation .....	26
unpacking and inspection .....	26

Introduction to ACS-2048 .....	11
--------------------------------	----

### Invalid

selection .....	44
signal .....	44

IP .....	101
address .....	59, 60
address, port 23 (Telnet) .....	93

ISEL (command) .....	102
----------------------	-----

ISTAT (command) .....	102
-----------------------	-----

IVCROP (command) .....	102
------------------------	-----

IVPAN (command) .....	102
-----------------------	-----

## L

Line voltage selection .....	28
------------------------------	----

List, commands .....	97
----------------------	----

LOCKOUT (command) .....	102
-------------------------	-----

Lockout, front panel .....	72
----------------------------	----



# Index

## M

MAC Address	60
Macrovision copy protection	50
Main Menu, using	41
Menu	
diagnostics	65
display	20
DVI cable equalizer	62
EDID DVI input format	60
Ethernet	58
factory reset	68
file association	64
gateway	59
hue/saturation color balance	48
image adjust	46
input	43
netmask	59
output	53
RGB color balance	47
rules and conventions	36
set static IP	59
software version	68
status	67
system	57
system temperature	62
test pattern	54
timing adjust	48
tree	35
usage, rules	36
user preference	63
Menu Context	22, 63, 67
input selection	70
test pattern	54
test patterns	71
Mini-DIN connector pinouts	88
Mode	
output	23, 53
test pattern	54

## N

Navigation cursor	20, 36
Netmask	
menu	59
set	59
Network config	58, 59
No Sync Detected	44
Notice	2
NTSC or PAL	19

## O

OCSAV (command)	103
-----------------	-----

Off (button)	21
OGM (command)	103
OMODE (command)	103
Operation	31
quick setup	33
Operators safety summary	4
ORBM (command)	103
ORES (command)	104
Orientation, hardware	17
OSTAT (command)	104
OTPM (command)	104
OTPT (command)	104
Output	
adjust size and position	13, 55
connections	30
DVI	23
format	53, 67
gamma	54
menu	53
mode	23, 53
mode, 8-bit, 10-bit, 12-bit	53
save configuration	56
scale	55
specifications	83
test pattern	54
type	67
Oversample	49
Over-temp	63
Overview	
control	32
software upgrade	74

## P

Page	
ACS-2048 upgrade	77
select file	77
upload status	78
Pan	46
PDF file usage	12
navigating and searching	12
Physical specifications	84
Pinouts	86
analog 15-pin D connector	86
DVI-I connector	87
Ethernet connector	88
Mini-DIN connector	88
Power	
cord, line voltage selection	28
installation	27
precautions	28
up and initialization	32
Processing menu	50
Program EDID	61
Protocol	
command	94

## Index

remote control	93
Pulldown Compensation	50

## Q

Query options	94
Quick	
function reference	38
setup and operations	33

## R

Rack mount installation	27
Raster Box	55
Ratio	46
Rear panel connectors	23
Recall input configuration	52
Reference, quick function table	38
Remote control protocol	93
Repeater, HDCP	15, 67
RESET	105
Reset	
all	48
config	50
factory	68
input configuration	50
Restart ACS-2048	78
Return material authorization	107
RGB color balance menu	47
RMA	107
Rules, input selection	69

## S

Safety	
precautions	26
summary	4
Sales contact information	108
Sample Phase	49
Sampling	49
Saturation	48
Save	
config	51, 56, 65
input configuration	51
output configuration	56
system config	65
system state	65
SAVE (command)	105
Scale output	55
SD-SDI	18
Section	
display	20
inputs	21

SEL	20
using	36, 37
Select file page	77
Selection, input rules	69
SELMODE (command)	105
Set	
gateway	59
netmask	59
static IP	59
Signal installation	29
Site preparation	26
Software	
downloading	75
requirements, upgrading	74
upgrade overview	74
upgrade via Ethernet	76
upgrading	73
version	33, 68
version menu	68
SOG	50
Specifications	81
agency	85
communications	85
electrical	84
input	82
input format table	89
output	83
physical	84
pinouts	86
Static IP	59
menu	59
Status	
HDCP	67
menu	67
menu, input format	67
menu, input type	67
menu, output format	67
menu, output type	67
SUBNET (command)	106
Support, technical information	3, 108
Symbols	12
Sync	
auto	50
CSync	50
selection	50
slice	50
SOG	50
System	
config, save	65
diagram	29
menu	57
temperature menu	62

## T

Table	
-------	--

## Index

format connections	30
input formats	89
quick function reference	38
Technical support information	3, 108
Telnet	23
using	93
TEMP (command)	106
Temperature	62
over-temp condition	63
Terms, equipment marking	5
TEST PAT	19, 71
how to use	22
Test pattern	
menu	54
menu context	71
mode	54
raster box	55
type	54
using	71
Timing	
1-1 sampling	49
adjust menu	48
oversample	49
Trademarks	3
Trans time	57
Transition	
time	57
type	57
Tree, menu	35
TRNTIME (command)	106
Troubleshoot Ethernet connection	79
Twin-Link DVI output	23
Type	
input	44
test pattern	54

## U

Understanding	
auto acquire	70
button backlighting	69
Universal inputs	13
Unpacking	26
Upgrade	
software	73
software via Ethernet	76
Upload	
dialog	78
status page	78
User preference	
all inputs sel	63
auto input save	63
menu	63
menu context	63
Using	
auto acquire	42

ESC button	36, 37
inputs	69
main menu	41
SEL button	36, 37
test patterns	71

## V

### V

active	49
crop	46
pan	46
position	49
total	49
Vacuum Fluorescent Display	20
VER (command)	106
Version, software	68
VFD	20
brightness	58
VFDBRT (command)	106
Video delay	14
Violation, HDCP	67

## W

Warranty	107
Web site	75

# Index