

# INSTALLATION INSTRUCTIONS

## C-CLAMP PIPE MOUNT CMA-362

The C-Clamp is adjustable to fit pipe, 2 X 4, Uni-Strut™ or structural members up to 2.75 (70.1mm) O.D.”.

**WARNING: IMPROPER INSTALLATION MAY RESULT IN SERIOUS PERSONAL INJURY!**

When mounting Chief Manufacturing accessories, the structural system and mounting method **MUST** be capable of supporting 5 times the combined weight of the total installation. The maximum weight to be installed on the ceiling plate is 250 pounds (113.3 Kg).

Unpack and check contents:

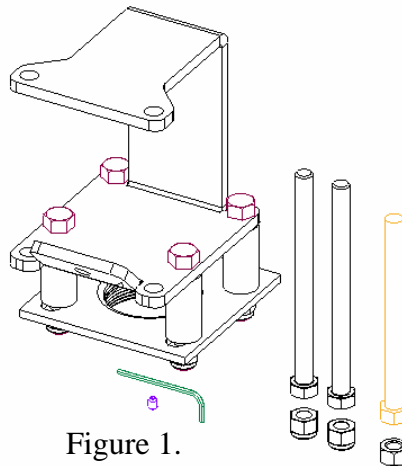

Figure 1.

- |                                     |                                    |
|-------------------------------------|------------------------------------|
| (1) C-Clamp Assembly                | (2) 3/8-16 X 5” Hex Head Cap Screw |
| (2) 3/8-16 Nylock Nut               | (1) 3/8-16 Hex Nut                 |
| (1) 3/8-16 X 4.5” Hex Head Tap Bolt | (1) 10-24 X 1/4” Set Screw         |
| (1) 3/32” Allen Wrench              |                                    |

- 1) Place clamp assembly on structure.
- 2) Install two 3/8-16 X 5” hex head cap screws and 3/8-16 Nylock nuts (see Figure 2).

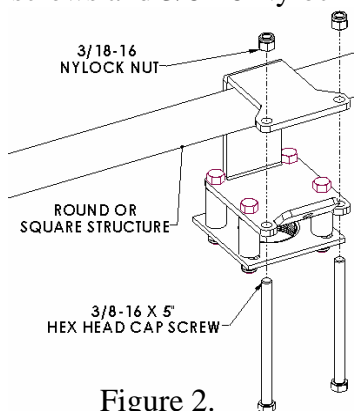

Figure 2.

- 3) Install the 3/8-16 hex nut on the 3/8-16 X 4.5" hex head tap bolt (see Figure 3).
- 4) Install the 3/8-16 X 4.5" hex head tap bolt in the C-clamp assembly.
- 5) Tighten the hex head tap bolt to secure the C-clamp assembly to the structure (see Figure 4).
- 6) Using the 3/8-16 hex nut as a jam nut, secure the 3/8-16 X 4.5" hex head tap bolt in place.
- 7) Install your 1 1/2" NPT pipe and secure using the 10-24 X 1/4" set screw (see Figure 5).

