

HD Color Video Camera User Manual



(English)

Preface:

Thanks for using our HD color video conference camera .

This manual introduces the function, installation and operation of the HD camera . Prior to installation and usage , please read the manual thoroughly .

Warning

This product can be only used in specified range in order to avoid any damage or danger;

Don't expose the camera to rain or moisture place

Don't remove the cover to reduce the risk of electric shock. Refer servicing to qualified personnel .

Never operate the camera under unqualified temperature , humidity and power supply;

Only use the replacement parts recommended by us.

Please use the soft cloth to clean the camera. Use neuter cleanser if bad smeared .No uses the strong or cleanser avoiding scuffing.

Be careful or moving; never press the drive parts heavily avoiding camera trouble.

Notes

Electromagnetic fields at the specific frequency may affect the image quality.

【Contents】

1. Notes
2. Accessories
3. Fast Installation.....
4. Camera Highlights.....
5. Camera specifications.....
6. Camera interface explanation.....
7. Remote Controller explanation.....
8. Usage of IR remote controller
9. VISCA RS-232 pin specs.....
10. Series COM Control
11. Menu Setting.....
12. Maintenance and Trouble Shooting.....

Notes

Electric Safety

Installation and operation must accord with electric safety standard

Caution to transport

Avoid stress, vibration and soakage in transport , storage and installation .

Polarity of power supply

The power supply of the product is $\pm 12V$, the max electrical current is **2.5A** .polarity of the power supply drawing.

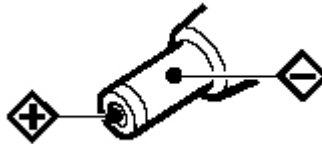

Careful of installation

Never move the camera by seizing the camera head . Don't rotate camera head by hand, otherwise, mechanical trouble will occur.

This series item must put on the smooth desk or platform , and it can not be installed slantways ;

If the camera is installed on TV or computer , the base can be fixed by three double-sided adhesive tray.

Don't apply in corrosive liquid , gas or solid environment to avoid the cover which is made up of organic material .

To make sure no obstacle in rotation range

Never power on before installation is not completed

Don't dispatch discretionarily

We are not responsible for any unauthorized modification or dismantling .

Supplied Accessories

When you unpack , check that all the supplied accessories are included :

Camera1
Power adapter1
Power cable..... 1
RS232 cable.....1
Remote controller.....1
User manual1
Double-side glue shim4

Fast Installation

1. Please check the connection before turn on .

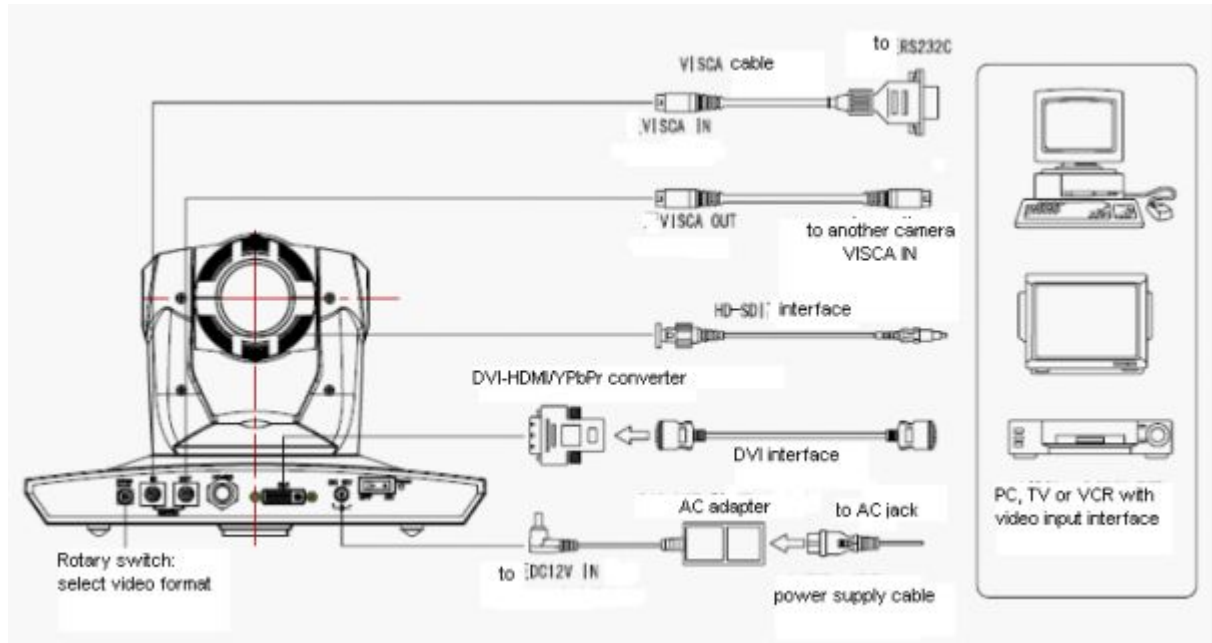

2, Bottom Dial Switch Setting

Set Two DIP switch "OFF", it is the Working Mode.

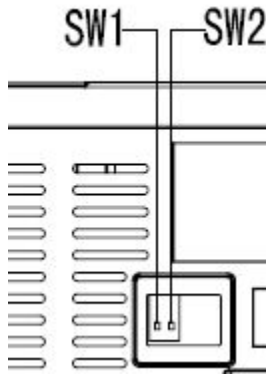

Setting and instruction bottom dial switch :

	SW-1	SW-2	Modes
1	OFF	OFF	Working mode
2	ON	OFF	Updating Mode
3	OFF	ON	Debugging Mode
4	ON	ON	NONE

3. The Rotary Switch Setting

Sixteen Rotary Switch setting for format setting selections:

Index	S	M	C
0	1080P60	-----	-----
1	1080P50	-----	-----
2	1080I60	1080I60	-----
3	1080I50	1080I50	-----
4	720P60	720P60	720P60
5	720P50	720P50	720P50
6	1080P30	1080P30	-----
7	1080P25	1080P25	-----
8	720P30	720P30	720P30
9	720P25	720P25	720P25
A	1080P59.94	-----	-----
B	1080I59.94	1080I59.94	-----
C	720P59.94	720P59.94	720P59.94
D	1080P29.97	1080P29.97	-----
E	720P29.97	720P29.97	720P29.97

Note: Please restart the camera after shift the video format

4, When Power supply switch is “on” ,the indicator light is open(red color)

5, Camera initializes after 5 seconds: Rotate to the right limit, move to the down limit; Then turn left, motor stops when horizontal and vertical rotation is in the middle, camera lens will move to the wide angel position. Initialization finishes . (Note : the camera will move to the preset position no.0 if saved 0 preset)

6, Restore default setting: enter into the OSD menu by press the menu key of remote controller, select **【Restore Default】** , moving the left/right key to press **【Yes】** , then confirm by **【HOME】** key .

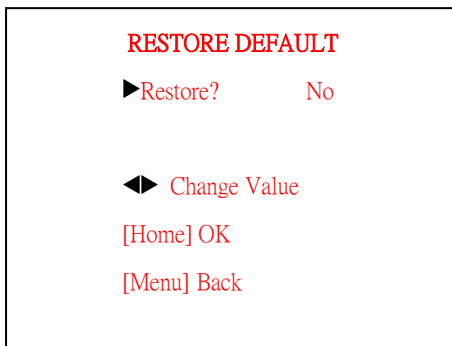

Camera highlights

1, low illumination solution, particularly suitable for the normal lighting situation meeting room.

2, To reach 1920 × 1080 pixel , the max video frame is 60/50 FPS . It definitely meet the requirement for both high clarity and picture smooth .

3, video's S/N ratio directly affect the HD video conference terminal's image compression coding efficiency. With 2D and motion-estimation based 3D noise reduction algorithm and U.S new generation low noise sensor, VHD820 has effectively reduce noise;

4, The unique Iridix exposure dynamic control algorithm, based on the human eye model, makes the image even exposure and strong sense of hierarchy; With the most advanced CMOS sensor which support WDR ,camera can capture all images clearly in the strong contrast between black and light environment(such as backlight);

5, **18×optical zoom**

6. Completed Interfaces , support DVI(can convert to YPbPr and HDMI output) interface , broadcast level HD-SDI interface .

7, IR remote controller signal transparent transmission function : camera can receive signal from both its own remote controller and terminal equipment controller, by transmitting the signal through VISCA IN to terminal equipment IR receiver.

Camera Specifications :

1. video format : 1080P60/50(S)、1080P30/25(S/M)、1080I60/50(S/M)、720P60/50/30/25 (S/M/C)
2. Output Interface : Support, DVI(can convert to YPbPr and HDMI Output) , HD-SDI(selectable)
3. **Image Sensor : 1/3 inch 5 Megapixel HD CMOS Sensor**
4. Focal : **f4.7mm-84.6mm , (18×optical zoom)** , F1.8-2.8, angle of view : **55.2°- 3.2°**.
5. the Rotation : $\pm 120^\circ$ for pan rotation , and $-30^\circ \sim +90^\circ$ for tilt rotation , support in-ceiling installation .
6. the Control speed ,: **1°-80°/sec** for pan rotation , **1°-60°/sec** for tilt rotation .
7. Preset position NO. : **10 preset positions (can reach to 128 by serial command)**, precision error less than 0.2° .
8. Support auto/ manual white balance , auto/manual exposure (iris , shuttle) , auto/manual focus
9. support WDR technical : performance $\geq 100\text{dB}$,
10. anti-flicker .
11. Control Signal interface : 8 pin mini DIN,RS232, VISCA/Pelco-D/Pelco-P
12. Power interface : HEC3800 power jack , Power supply adapter: **DC12V/2.5A** ,
13. working temperature: -5°C to $+50^\circ\text{C}$
14. Storage temperature: -20°C to $+60^\circ\text{C}$

Camera Interface Explanation

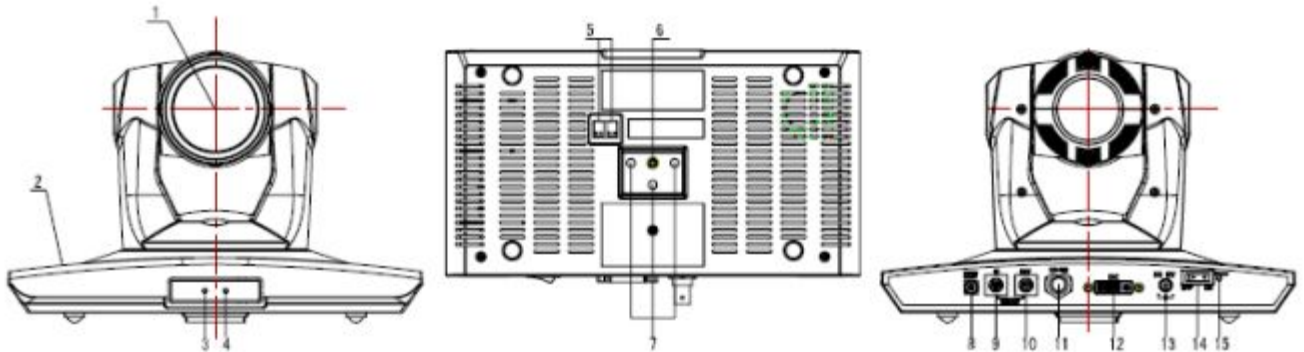

- 1.Camera lens
- 2.Camera base
- 3.Power indicator light (red)
- 4.Remote Controller Receiver light (red)
- 5.Bottom dial Switch
- 6.Tripod screw hole
- 7.Installation Orientation Hole
- 8.Rotary Switch : video format optional
- 9.RS232 controller serial interface (input)
- 10.RS232 controller serial interface (output)

11.HD-SDI High Definition Serial Digital Signal interface

12.DVI-I interface(can convert to YPbPr and DVI(HDMI) HD Digital Output)

13.DC12V Input Power Supply Jack

14.Power Switch

15.Power indicator light(red)

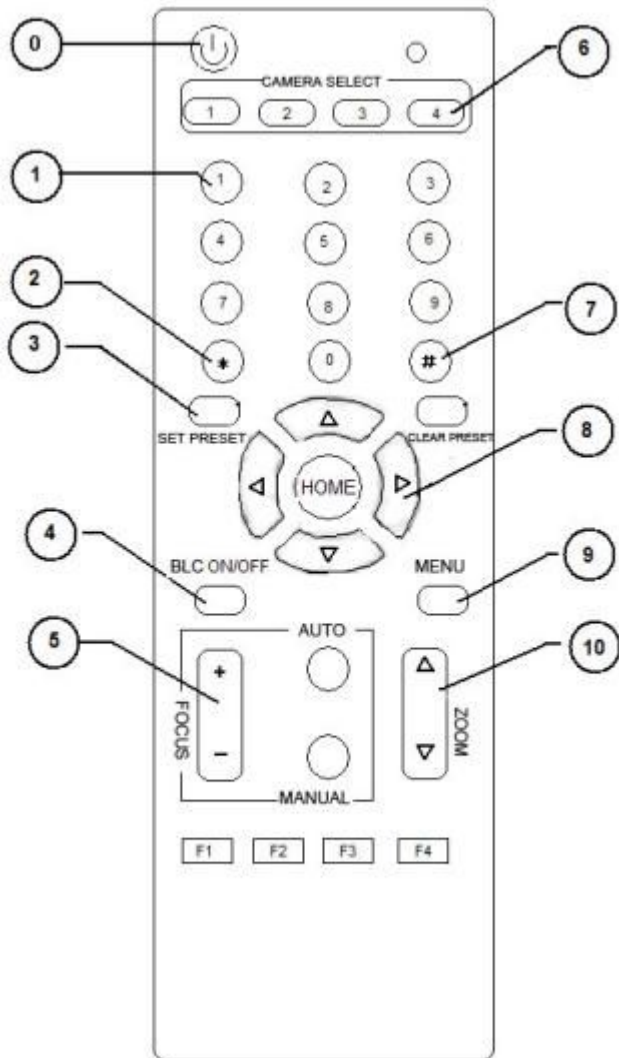

Remote Controller:

Definition of IR controller

0、 Standby key

After pressing the standby key, the camera will step into standby mode.Press again,the camera will open again.(Note: Standby mode power consumption is about half of the normal mode)

1、 Number key

Setting or locating presets

2、 * key

Key combination use

Set preset key:

Set preset:

Set preset key + 0-9 number key:

Clear preset key:

Clear preset key + 0-9 number key

or: # + # + # : clear all the presets

4、BLC control key

BLC ON: open black light compensation (only work when exposure mode setting is Auto)

BLC OFF: close black light compensation (Only available in the exposure mode effective for Auto)

5、Focus control key

Focus+: focus length far from near

Focus-: focus length near from far

Auto focus: the camera focus mode is auto

Manual focus: the camera focus mode is manual

6、Camera address selection

Select the camera which want to be controlled

7、# key

Key combination use

8、pan/tilt control key

Press ▲ key : up

Press ▼ key : down

Press ◀ key : left

Press ▶ key: right

“HOME” key: Return to the middle position

9、Menu setting

Open or close the OSD menu

10、Zoom Control key

zoom+: lens near

zoom-: lens far

11.controlling camera address selection

【*】 + 【#】 + 【F1】: Camera Address No.1

【*】 + 【#】 + 【F2】: Camera Address No. 2

【*】 + 【#】 + 【F3】: Camera Address No. 3

【*】 + 【#】 + 【F4】: Camera Address No. 4

IR Remote Control

When the camera is working, users can control the pan/tilt/zoom, setting and taking preset positions via remote controller.

Instruction:

- 1、 In this instruction, “press the key” means a click rather than a long-press, and a special note will be given if a long-press for more than one second is required.
- 2、 When a key-combination is required, do it in sequence. For example, “*#+F1” means press “*” first and then press “#” and press “F1” at last.

Pan/Tilt Control

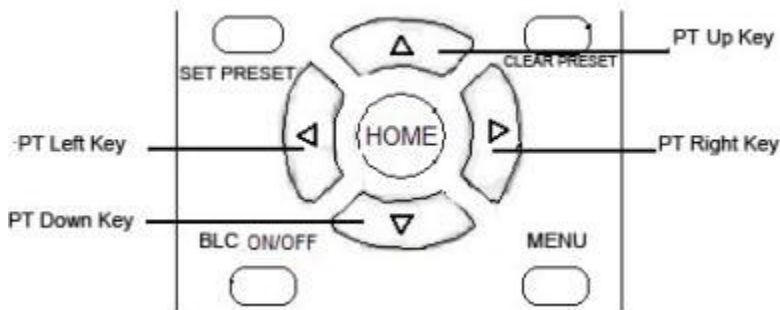

Up: press ▲
Down: press ▼
Left: press ◀
Right: press ▶

Back to middle position: press“HOME”

Press and hold the up/down/left/right key, the pan/tilt will keep running, from slow to fast, until it run to the endpoint; The pan/tilt running stops as soon as the key is released.

2. Zoom Operation

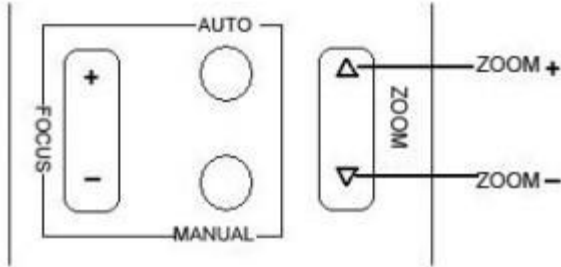

ZOOM OUT: press “ZOOM ▲” key

ZOOM IN: press “ZOOM ▼” key

Press and hold the key, the camera will keep zooming in or zooming out and stops as soon as the key is released.

3. Focus Control

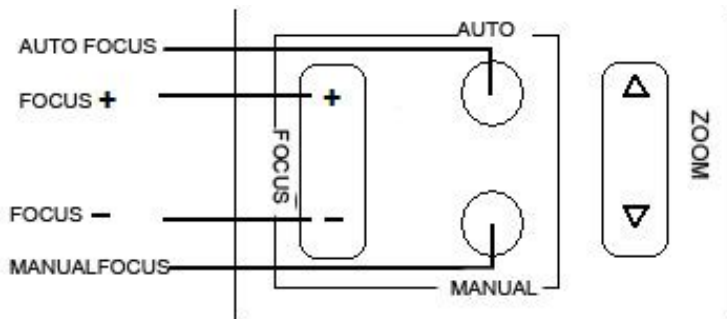

Focus (far): Press "focus+" key

Focus (near): Press "focus-"key

Auto Focus: Press "auto"

Manual Focus: Press "manual"

Press and hold the key, the action of focus continues and stops as soon as the key is released.

4.BLC Setting



BLC ON: Press BLC ON/OFF

BLC OFF: Press again

5.Presets setting

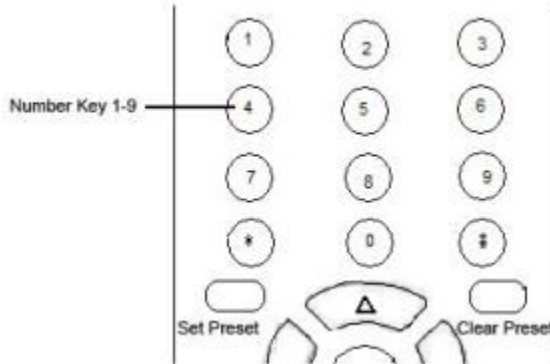

- 1、Preset setting : to set a preset position, the users should press the “SET PRESET” key first and then press the number key 0-9 to set a relative preset, 10 preset positions in total are available.
 - 2、Preset clearing : to clear a preset position, the user can press the “CLEAR PRESET” key first and then press the number key 0-9 to clear the relative preset;
- Note : press the “#” key three times continually to cancel all the presets.

6、Preset locating

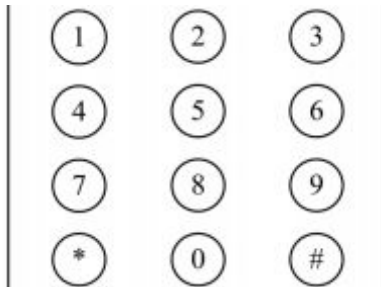

Press a number key 0-9 directly to run a relative preset.

Note: Action in vain if a relative preset position is not existed.

7. Camera Address Setting

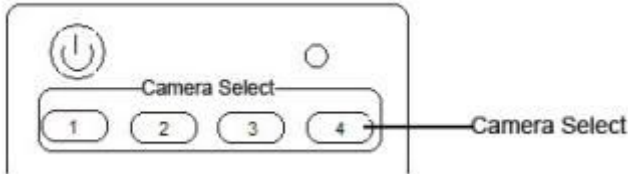

Select the camera you want to controller by press the number key

8. Camera Remote Controller Address Setting

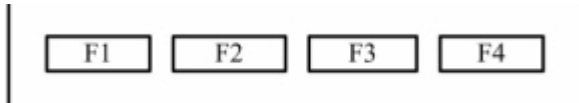

【*】+【#】+【F1】: Camera Address No.1

【*】+【#】+【F2】: Camera Address No. 2

【*】+【#】+【F3】: Camera Address No. 3

【*】+【#】+【F4】: Camera Address No. 4

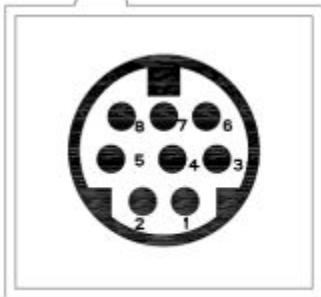

RS-232C Interface (Pin Specs)

Camera Windows DB-9

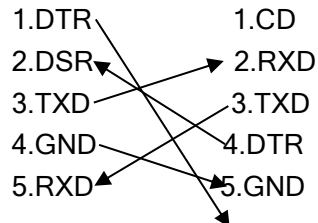

6.GND 6.DSR
 7.IR OUT 7.RTS
 8.NC 8.CTS
 9.RI

Camera

Windows DB-25

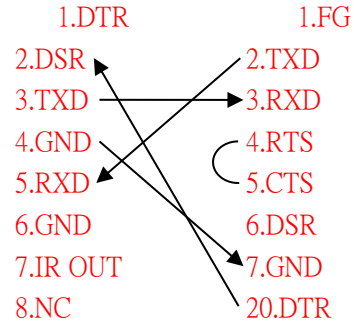
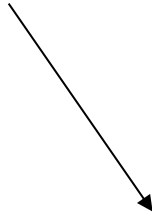

No.	Function
1	DTR
2	DSR
3	TXD
4	GND
5	RXD

6	GND
7	IR OUT
8	NC

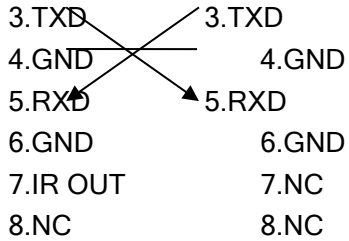
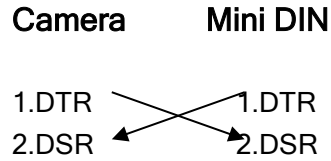

VISCA OUT Function

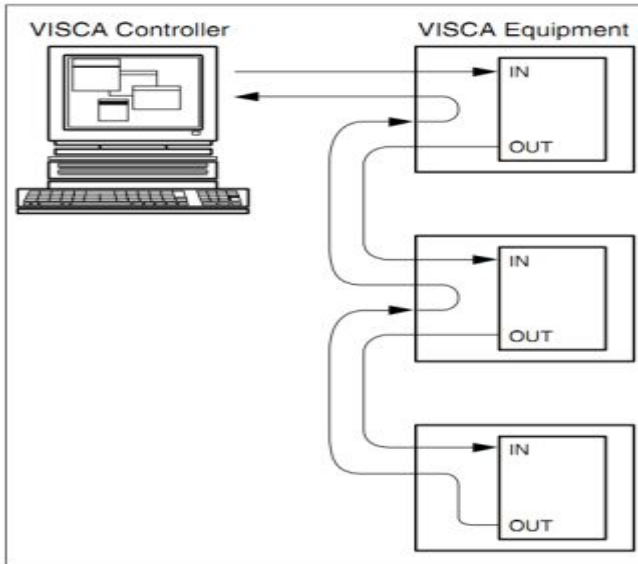

COM Control

In default working mode, the camera is able to be controlled via RS-232C command (VISCA IN) . the parameter of the RS232C COM as following :

Baud Rate : 9600 Bit/S

Start bit: 1bit ;

Data bit: 8bit ;

Stop bit : 1bit;

Code: None

Connected to power, the camera runs to the right middle position, with the farthest zoom rate, auto focusing and default iris data. The camera run into the preset no.0 if it was saving. After finish this initialization the users can control the pan/tilt/zoom via RS-232 command.

VISCA Protocol

Part1 . Camera Return Command

Ack/Completion Message		
	Command Packet	Note
ACK	z0 41 FF	Returned when the command is accepted.
Completion	z0 51 FF	Returned when the command has been executed.

z = Camera Address + 8

Error Messages		
	Command Packet	Note
Syntax Error	z0 60 02 FF	Returned when the command format is different or when a command with illegal command parameters is accepted

Command Executable	Not	z0 61 41 FF	Returned when a command cannot be executed due to current conditions. For example, when commands controlling the focus manually are received during auto focus.
--------------------	-----	-------------	---

Part 2 Controlling Command

Command	Function	Command packet	Note
AddressSet	Broadcast	88 30 01 FF	Address setting
IF_Clear	Broadcast	88 01 00 01 FF	I/F Clear
CommandCancel		8x 21 FF	
CAM_Power	On	8x 01 04 00 02 FF	Power ON/OFF
	Off	8x 01 04 00 03 FF	
CAM_Zoom	Stop	8x 01 04 07 00 FF	
	Tele(Standard)	8x 01 04 07 02 FF	
	Wide(Standard)	8x 01 04 07 03 FF	
	Tele(Variable)	8x 01 04 07 2p FF	p = 0(low) - 7(high)
	Wide(Variable)	8x 01 04 07 3p FF	
	Direct	8x 01 04 47 0p 0q 0r 0s FF	pqrs: Zoom Position
CAM_Focus	Stop	8x 01 04 08 00 FF	
	Far(Standard)	8x 01 04 08 02 FF	
	Near(Standard)	8x 01 04 08 03 FF	
	Far(Variable)	8x 01 04 08 2p FF	p = 0(low) - 7(high)
	Near(Variable)	8x 01 04 08 3p FF	

	e)		
	Direct	8x 01 04 48 0p 0q 0r 0s FF	pqrs: Focus Position
	Auto Focus	8x 01 04 38 02 FF	AF ON/OFF
	Manual Focus	8x 01 04 38 03 FF	
	Auto/Manual	8x 01 04 38 10 FF	
CAM_ZoomFocus	Direct	8x 01 04 47 0p 0q 0r 0s 0t 0u 0v 0w FF	pqrs: Zoom Position tuvw: Focus Position
CAM_WB	Auto	8x 01 04 35 00 FF	Normal Auto
	Indoor mode	8x 01 04 35 01 FF	Indoor mode
	Outdoor mode	8x 01 04 35 02 FF	Outdoor mode
	OnePush mode	8x 01 04 35 03 FF	One Push WB mode
	Manual	8x 01 04 35 05 FF	Manual Control mode
CAM_RGain	Reset	8x 01 04 03 00 FF	Manual Control of R Gain
	Up	8x 01 04 03 02 FF	
	Down	8x 01 04 03 03 FF	
	Direct	8x 01 04 43 00 00 0p 0q FF	pq: R Gain
CAM_Bgain	Reset	8x 01 04 04 00 FF	Manual Control of B Gain
	Up	8x 01 04 04 02 FF	
	Down	8x 01 04 04 03 FF	
	Direct	8x 01 04 44 00 00 0p 0q FF	pq: B Gain
CAM_AE	Full Auto	8x 01 04 39 00 FF	Automatic Exposure mode
	Manual	8x 01 04 39 03 FF	Manual Control mode
	Shutter priority	8x 01 04 39 0A FF	Shutter Priority Automatic Exposure mode

	Iris priority	8x 01 04 39 0B FF	Iris Priority Automatic Exposure mode
	WDR	8x 01 04 39 21 FF	WDR mode
CAM_Shutter	Reset	8x 01 04 0A 00 FF	Shutter Setting
	Up	8x 01 04 0A 02 FF	
	Down	8x 01 04 0A 03 FF	
	Direct	8x 01 04 4A 00 00 0p 0q FF	pq: Shutter Position
CAM_Iris	Reset	8x 01 04 0B 00 FF	Iris Setting
	Up	8x 01 04 0B 02 FF	
	Down	8x 01 04 0B 03 FF	
	Direct	8x 01 04 4B 00 00 0p 0q FF	pq: Iris Position
CAM_WDRStrength	Reset	8x 01 04 21 00 FF	WDR Level Setting
	Up	8x 01 04 21 02 FF	
	Down	8x 01 04 21 03 FF	
	Direct	8x 01 04 51 00 00 0p 0q FF	pq: WDR Level Position
CAM_ExpComp	On	8x 01 04 3E 02 FF	Exposure Compensation ON/OFF
	Off	8x 01 04 3E 03 FF	
	Reset	8x 01 04 0E 00 FF	Exposure Compensation Amount Setting
	Up	8x 01 04 0E 02 FF	
	Down	8x 01 04 0E 03 FF	
	Direct	8x 01 04 4E 00 00 0p 0q FF	pq: ExpComp Position
CAM_BackLight	On	8x 01 04 33 02 FF	Back Light Compensation ON/OFF
	Off	8x 01 04 33 03 FF	
CAM_NR(2D)	-	8x 01 04 53 0p FF	p: NR Setting (0: OFF, level 1 to 5)
CAM_NR(3D)	-	8x 01 04 54 0p FF	p: NR Setting (0: OFF, level 1 to 5)
CAM_Flicker	-	8x 01 04 23 0p FF	p: Flicker Settings(0: OFF, 1: 50Hz, 2:

			60Hz)
CAM_Aperture	Reset	8x 01 04 02 00 FF	Aperture Control
	Up	8x 01 04 02 02 FF	
	Down	8x 01 04 02 03 FF	
	Direct	8x 01 04 42 00 00 0p 0q FF	pq: Aperture Gain
CAM_Memory	Reset	8x 01 04 3F 00 0p FF	p: Memory Number(=0 to 9) Corresponds to 0 to 9 on the Remote Commander.(Different with EVI-HD1)
	Set	8x 01 04 3F 01 0p FF	
	Recall	8x 01 04 3F 02 0p FF	
CAM_LR_Revers e	On	8x 01 04 61 02 FF	Image Flip Horizontal ON/OFF
	Off	8x 01 04 61 03 FF	
CAM_PictureFlip	On	8x 01 04 66 02 FF	Image Flip Vertical ON/OFF
	Off	8x 01 04 66 03 FF	
CAM_ColorGain	Diret	8x 01 04 49 00 00 00 0p FF	p: Color Gain setting 0h (60%) to Eh (200%)
CAM_ICR	ON	8x 01 04 01 02 FF	Infrared Mode ON/OFF
	OFF	8x 01 04 01 03 FF	
CAM_IDWrite		8x 01 04 22 0p 0q 0r 0s FF	pqrs: Camera ID (=0000 to FFFF)
IR_Receive	On	8x 01 06 08 02 FF	IR(remote commander)receive ON/OFF
	Off	8x 01 06 08 03 FF	
	On/Off	8x 01 06 08 10 FF	
IR_ReceiveRetur n	On	8x 01 7D 01 03 00 00 FF	IR(remote commander)receive message via the VISCA communication ON/OFF
	Off	8x 01 7D 01 13 00 00 FF	
Pan_tiltDrive	Up	8x 01 06 01 VV WW 03 01 FF	VV: Pan speed 0x01 (low speed) to 0x18 (high speed)
	Down	8x 01 06 01 VV WW 03 02 FF	WW: Tilt speed 0x01 (low speed) to 0x14 (high speed)
	Left	8x 01 06 01 VV WW 01 03 FF	YYYY: Pan Position(TBD) ZZZZ: Tilt Position(TBD)

	Right	8x 01 06 01 VV WW 02 03 FF	
	Upleft	8x 01 06 01 VV WW 01 01 FF	
	Upright	8x 01 06 01 VV WW 02 01 FF	
	DownLeft	8x 01 06 01 VV WW 01 02 FF	
	DownRight	8x 01 06 01 VV WW 02 02 FF	
	Stop	8x 01 06 01 VV WW 03 03 FF	
	AbsolutePosition	8x 01 06 02 VV WW 0Y 0Y 0Y 0Y 0Z 0Z 0Z 0Z FF	
	RelativePosition	8x 01 06 03 VV WW 0Y 0Y 0Y 0Y 0Z 0Z 0Z 0Z FF	
	Home	8x 01 06 04 FF	
	Reset	8x 01 06 05 FF	

Part3 Checking Command

Command	Command packet	Return packet	Note
CAM_PowerInq	8x 09 04 00 FF	y0 50 02 FF	On
		y0 50 03 FF	Off(Standby)
CAM_ZoomPosInq	8x 09 04 47 FF	y0 50 0p 0q 0r 0s FF	pqrs: Zoom Position

CAM_FocusAFModelInq	8x 09 04 38 FF	y0 50 02 FF	Auto Focus
		y0 50 03 FF	Manual Focus
CAM_FocusPosInq	8x 09 04 48 FF	y0 50 0p 0q 0r 0s FF	pqrs: Focus Position
CAM_WBModelInq	8x 09 04 35 FF	y0 50 00 FF	Auto
		y0 50 01 FF	Indoor mode
		y0 50 02 FF	Outdoor mode
		y0 50 03 FF	OnePush mode
		y0 50 05 FF	Manual
		y0 50 2p FF	p:Color Temperature
CAM_RGainInq	8x 09 04 43 FF	y0 50 00 00 0p 0q FF	pq: R Gain
CAM_BGainInq	8x 09 04 44 FF	y0 50 00 00 0p 0q FF	pq: B Gain
CAM_AEModelInq	8x 09 04 39 FF	y0 50 00 FF	Full Auto
		y0 50 03 FF	Manual
		y0 50 0A FF	Shutter priority
		y0 50 0B FF	Iris priority
		y0 50 21 FF	WDR
		y0 50 22 FF	Low Light
CAM_ShutterPosInq	8x 09 04 4A FF	y0 50 00 00 0p 0q FF	pq: Shutter Position
CAM_IrisPosInq	8x 09 04 4B FF	y0 50 00 00 0p 0q FF	pq: Iris Position
CAM_WDRStrengthInq	8x 09 04 B1 FF	y0 50 00 00 0p 0q FF	pq: WDR Strength
CAM_ExpCompModelInq	8x 09 04 3E FF	y0 50 02 FF	On
		y0 50 03 FF	Off
CAM_ExpCompPosInq	8x 09 04 4E FF	y0 50 00 00 0p 0q	pq: ExpComp Position

		FF	
CAM_BacklightModelnq	8x 09 04 33 FF	y0 50 02 FF	On
		y0 50 03 FF	Off
CAM_Noise2DModelnq	8x 09 04 53 FF	y0 50 0p FF	Noise Reduction (2D) p: 0 to 5
CAM_Noise3DModelnq	8x 09 04 54 FF	y0 50 0p FF	Noise Reduction (3D) p: 0 to 5
CAM_FlickerModelnq	8x 09 04 55 FF	y0 50 0p FF	p: Flicker Settings(0: OFF, 1: 50Hz, 2: 60Hz)
CAM_ApertureInq	8x 09 04 42 FF	y0 50 00 00 0p 0q FF	pq: Aperture Gain
CAM_MemoryInq	8x 09 04 3F FF	y0 50 0p FF	p: Memory number last operated.
SYS_MenuModelnq	8x 09 06 06 FF	y0 50 02 FF	On
		y0 50 03 FF	Off
CAM_LR_ReverseInq	8x 09 04 61 FF	y0 50 02 FF	On
		y0 50 03 FF	Off
CAM_PictureFlipInq	8x 09 04 66 FF	y0 50 02 FF	On
		y0 50 03 FF	Off
CAM_IDInq	8x 09 04 22 FF	y0 50 0p 0q 0r 0s FF	pqrs: Camera ID
CAM_VersionInq	8x 09 00 02 FF	y0 50 ab cd mn pq rs tu vw FF	ab: Factory Code(08: VHD) cd: Hardware Version mnpq: ARM Version rstu: FPGA Version vw: Socket Number
VideoSystemInq	8x 09 06 23 FF	y0 50 00 FF	1920x1080i60
		y0 50 01 FF	1920x1080p30
		y0 50 02 FF	1280x720p60
		y0 50 03 FF	1280x720p30
		y0 50 07 FF	1920x1080p60
		y0 50 08 FF	1920x1080i50

		y0 50 09 FF	1920x1080p25
		y0 50 0A FF	1280x720p50
		y0 50 0B FF	1280x720p25
		y0 50 0F FF	1920x1080p50
Pan-tiltMaxSpeedInq	8x 09 06 11 FF	y0 50 ww zz FF	ww: Pan Max Speed zz: Tilt Max Speed
Pan-tiltPosInq	8x 09 06 12 FF	y0 50 0w 0w 0w 0w 0z 0z 0z 0z FF	www: Pan Position zzzz: Tilt Position

Note : **【x】** means the camera address you want to control , **【y】 = 【x + 8】**。

Pelco-D Protocol

Function	Byte1	Byte2	Byte3	Byte4	Byte5	Byte6	Byte7
Up	0xFF	Address	0x00	0x08	Pan Speed	Tilt Speed	SUM
Down	0xFF	Address	0x00	0x10	Pan Speed	Tilt Speed	SUM
Left	0xFF	Address	0x00	0x04	Pan Speed	Tilt Speed	SUM
Right	0xFF	Address	0x00	0x02	Pan Speed	Tilt Speed	SUM
Zoom In	0xFF	Address	0x00	0x20	0x00	0x00	SUM
Zoom Out	0xFF	Address	0x00	0x40	0x00	0x00	SUM
Focus Far	0xFF	Address	0x00	0x80	0x00	0x00	SUM
Focus Near	0xFF	Address	0x01	0x00	0x00	0x00	SUM
Set Preset	0xFF	Address	0x00	0x03	0x00	Preset ID	SUM
Clear Preset	0xFF	Address	0x00	0x05	0x00	Preset ID	SUM
Call Preset	0xFF	Address	0x00	0x07	0x00	Preset ID	SUM
Auto Focus	0xFF	Address	0x00	0x2B	0x00	0x01	SUM
Manual Focus	0xFF	Address	0x00	0x22	0x00	0x02	SUM

		ss	0	B			M
Query Pan Position	0xFF	Address	0x00	0x51	0x00	0x00	SUM
Query Pan Position Response	0xFF	Address	0x00	0x59	Value High Byte	Value Low Byte	SUM
Query Tilt Position	0xFF	Address	0x00	0x53	0x00	0x00	SUM
Query Tilt Position Response	0xFF	Address	0x00	0x5B	Value High Byte	Value Low Byte	SUM
Query Zoom Position	0xFF	Address	0x00	0x55	0x00	0x00	SUM
Query Zoom Position Response	0xFF	Address	0x00	0x5D	Value High Byte	Value Low Byte	SUM

Pelco-P Protocol

Function	Byte 1	Byte 2	Byte 3	Byte 4	Byte5	Byte6	Byte 7	Byte 8
Up	0xA0	Address	0x00	0x08	Pan Speed	Tilt Speed	0xAF	XOR
Down	0xA0	Address	0x00	0x10	Pan Speed	Tilt Speed	0xAF	XOR
Left	0xA0	Address	0x00	0x04	Pan Speed	Tilt Speed	0xAF	XOR

Right	0xA0	Address	0x00	0x02	Pan Speed	Tilt Speed	0xAF	XOR
Zoom In	0xA0	Address	0x00	0x20	0x00	0x00	0xAF	XOR
Zoom Out	0xA0	Address	0x00	0x40	0x00	0x00	0xAF	XOR
Focus Far	0xA0	Address	0x00	0x80	0x00	0x00	0xAF	XOR
Focus Near	0xA0	Address	0x01	0x00	0x00	0x00	0xAF	XOR
Set Preset	0xA0	Address	0x00	0x03	0x00	Preset ID	0xAF	XOR
Clear Preset	0xA0	Address	0x00	0x05	0x00	Preset ID	0xAF	XOR
Call Preset	0xA0	Address	0x00	0x07	0x00	Preset ID	0xAF	XOR
Auto Focus	0xA0	Address	0x00	0x2B	0x00	0x01	0xAF	XOR
Manual Focus	0xA0	Address	0x00	0x2B	0x00	0x02	0xAF	XOR

							F	R
Query Pan Position	0xA0	Address	0x00	0x51	0x00	0x00	0xAF	XOR
Query Pan Position Response	0xA0	Address	0x00	0x59	Value High Byte	Value Low Byte	0xAF	XOR
Query Tilt Position	0xA0	Address	0x00	0x53	0x00	0x00	0xAF	XOR
Query Tilt Position Response	0xA0	Address	0x00	0x5B	Value High Byte	Value Low Byte	0xAF	XOR
Query Zoom Position	0xA0	Address	0x00	0x55	0x00	0x00	0xAF	XOR
Query Zoom Position Response	0xA0	Address	0x00	0x5D	Value High Byte	Value Low Byte	0xAF	XOR

Menu Setting

1. Main Menu

In normal image condition, press “MENU” key to display the menu, using scroll arrow to point at or highlight the selected items.

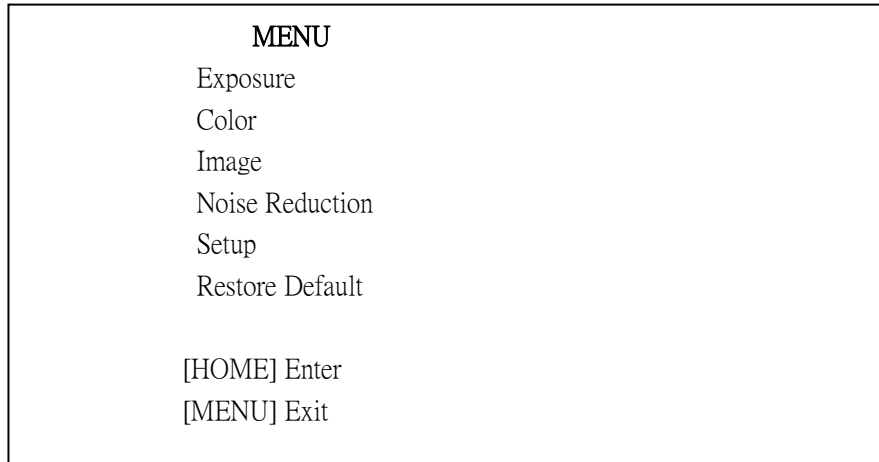

2. EXPOSURE

Choose and enter the EXPOSURE item (by using up/down/left/right and HOME key)

EXPOSURE

▶MODE	Auto
EV	Off
EVLevel	0
BLC	Off
G.Limit	7
Flicker	Off
Meter	Average

▲▼ Select Item

◀▶ Change Value

[Menu] Back

Mode: Exposure Mode, five options available: Auto, Manual, AAE, SAE, And WDR

EV: Exposure Value: Off, On

EVLevel: Exposure compensation levels: -7~+7

BLC: Back Light Compensation: Off, On

G Limit: Biggest gain limit: 0~ +7

Flicker: Anti-Flicker: Off, 50Hz, 60Hz

Iris: Iris value, we have F1.8, F2.0, F2.4, F2.8, F3.4, F4.0, F4.8, F5.6, F6.8, F8.0, F9.6, and F11 for options (only available in the mode of Manual and AAE)

Shut: Shutter value: 1/30, 1/60, 1/90, 1/100, 1/125, 1/180, 1/250, 1/350, 1/500, 1/725, 1/1000, 1/1500, 1/2000, 1/3000, 1/4000, 1/6000, 1/10000 (only available in the mode of Manual and SAE)

Stren: WDR strength: 0~6 (only available in the mode of WDR)

Meter : meter model , Average , Center optional .

3. COLOR

Choose and enter the COLOR item (by using up/down/left/right and HOME key)

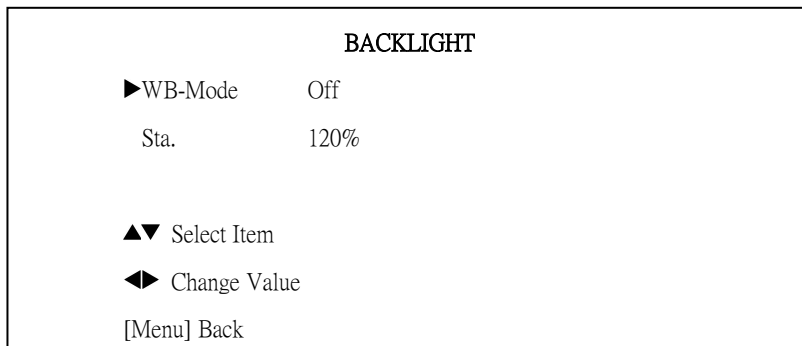

WB-Mode: White balance mode: Auto, Indoor, Outdoor, OnePush , Manual

RG: Red Gain: -5~+5 (only available in the mode of Manual)

BG: Blue Gain: -5~+5 (only available in the mode of Manual)

Sat.: Saturation: 60% ~ 200%

4. IMAGE

Choose and enter the Image item (by using up/down/left/right and HOME key)

IMAGE	
▶ Brightness	0
Contrast	0
Sharpness	0
B&W-Mode	Off
Flip-H	On
Flip-V	On
▲▼ Select Item	
◀▶ Change Value	
- - - - -	

Brightness: -5 ~ +5 value setting

Contrast: -5 ~ +5 value setting

Sharpness: 0 ~ 15 value setting

B&W-Mode: On, Off

Flip-H: Image Flip Horizontal: On, Off

Flip-V: Image Flip Vertical: On, Off

5. NOISE REDUCTION

Choose and enter the Noise Reduction item (by using up/down/left/right and HOME key)

NOISE REDUCTION

▶NR2D-Level 4
NR3D-Level 3
D-HotPixel Off
DarkDetail 5

▲▼ Select Item

◀▶ Change Value

NR2D-Level: 2D Noise Reduction: Off, 1 ~ 5

NR2D-Level: 3D Noise Reduction: Off, 1 ~ 5

Note: The higher the noise reduction level, the less image detail.

6. SETUP

Choose and enter the Setup item (by using up/down/left/right and HOME key)

SETUP

▶Language	EN
Protocol	VISCA
V.Addr	1
Baudrate	9600
SpeedByZ	On
AF-Sense	Low

▲▼ Select Item

◀▶ Change Value

[Menu] Back

Language: only support English.

Protocol: VISCA, P-D, P-P

V. Addr: VISCA (able to set 1~7), P-D and P-P (able to set 1~15)

Baud rate: 2400, 4800, 9600

SpeedByz: Speed by Zoom , On . Off optional

AF-Sense : auto focus sense setting , Low , Normal , High optional

7. RESTORE DEFAULT

Choose and enter the RESTORE DEFAULT item (by using up/down/left/right and HOME key)

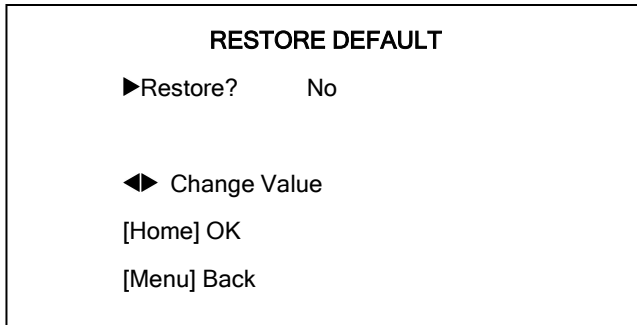

Restore: Yes or No **Note:** You need to enter the HOME key to confirm.

8. EXIT

Enter the MENU key once again, you will see this interface.

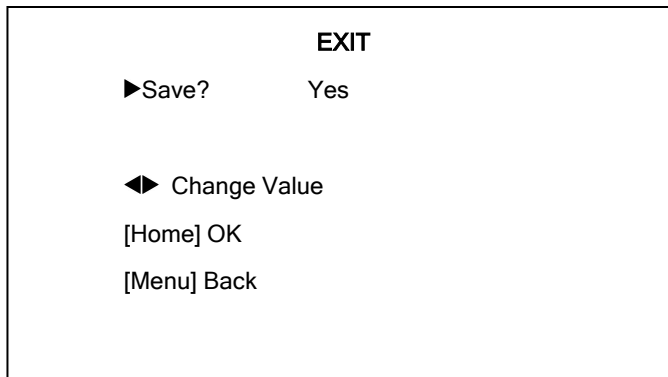

Save: Yes or No **Note:** You need to enter the HOME key to confirm.

Maintenance and Troubleshooting

Camera Maintains

If camera is not used for long time, please turn off power switch, adapter switch and AC plug.

Use soft cloth or tissue to clean the camera cover.

Use soft cloth to clean the lens; Use neuter cleanser if bad smeared. No use strong or corrosive cleanser or corrosive cleanser avoiding scuffing.

Unqualified Application

No shooting extreme light object, such as sunlight, lamplight etc.

No operating in unstable light environment, otherwise image will twinkle

No operating in radio wave with great power environment, such as TV station or Wireless Launcher etc.

Image effective will not be good when the light is not accordant with camera's lux.

Troubleshooting

Image

No image

- 1, Check whether the power cord, voltage is OK, power indicator light is ON.
- 2, Turn off the power supply to check whether the camera can auto configure.
- 3, Check the dial switch in bottom and make sure the two dial position are all on OFF.
- 4, Check video and TV wire is connected correctly.

Abnormal display of image

Check whether the video connecting wires is well and other connecting sockets and camera flat wires are well.

The camera can only works at one focus, other position can not be focused.

Change the position to see if this phenomenon still exists. If yes, it may be caused by Camera control drive focus control system trouble.

Image dithering when at Maximum Zoom

- 1, Check whether camera is fixed correctly.
- 2, If there is vibrative mechanical object.

Remote Controller

- 1, Change the battery
- 2, Check the camera operation mode is right.

Terminal

- 1, Check the camera operation mode is right.
- 2, Check control wire is connected correctly.